

KENDALL HOWARD

Assembly and Maintenance Manual

---



Workbenches LAN Stations  
And Accessories

# Your New Performance Workstation

Congratulations on your new Kendall Howard Performance LAN Station Workbench. This manual will step you through the assembly process. If you have trouble, please feel free to call our customer service department from 8:30 AM to 5:30 PM CST.

## Step 1. Inventory

Please be sure that you unpack the crate completely and take a complete inventory of what you have received. This will save you much time if parts are missing and you have to stop in the middle of the build process. We take every precaution to ensure that you do receive all parts required; however accidents do happen in shipping that may cause the loss of a key part. If you suspect that you are missing parts, please contact our customer service department immediately at 651-340-1400. You will need to have your order confirmation number before you call.

PART	QTY	PART	QTY
Levelers	4	3/4" Round Plastic End Cap	16
Table Sides (1 left, 1 right)	2	1 1/2" Square Plastic End Cap	4
Cross Bars	6	1 1/2" x 2" Rectangle End Cap	4
Upper Shelf Supports	4	Channel Nut	8
Upper Shelf Channels	2	1 1/2 Hex Drive Bolt	16
Lower Shelf	1	2 1/2" Hex Drive Bolt	4
Upper Shelf	2	T-Handle Hex Wrench	1
Work Surface	1	Cross Head Screw	12 (24")
Cable Tray/Back Support	1		15 (48"), 24 (72"), 30 (96")

## Step 2. Assemble the Upper Shelves

Place the upper shelves so that the hardware inserts are facing up. Next, place one of the cross bars on the shelf lining up the holes on the shelf with the brackets on the cross bar. Insert (2) cross head screws but **DO NOT FULLY TIGHTEN**. You will notice a small gap between the bracket and the shelf. This was designed so that after the bench is assembled, you will tighten all the cross head screws which will pull the shelf down tight against the frame.

With the shelves still in the same position as in step 2, place a left and a right shelf support on the shelf and attach with (2) 1 ½ Hex Drive Bolts.

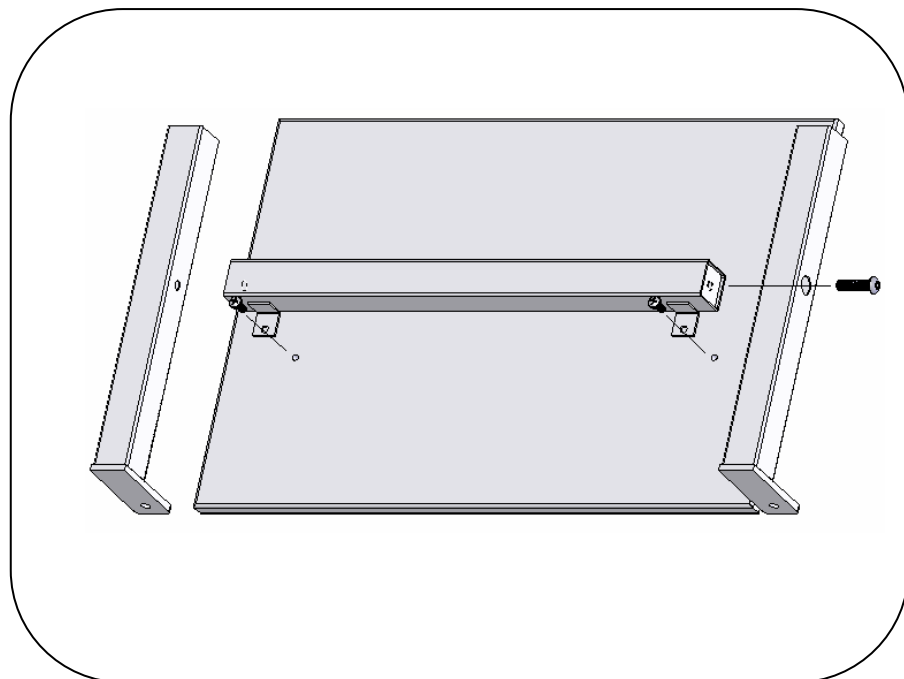

### Step 3. Assemble the Work Surface

With the work surface placed with the hardware inserts facing up, attach 2 cross bars to the shelf with (4) cross head screws but **DO NOT FULLY TIGHTEN**. You will notice a small gap between the bracket and the shelf. This was designed so that after the bench is assembled, you will tighten all the cross head screws which will pull the shelf down tight against the frame.

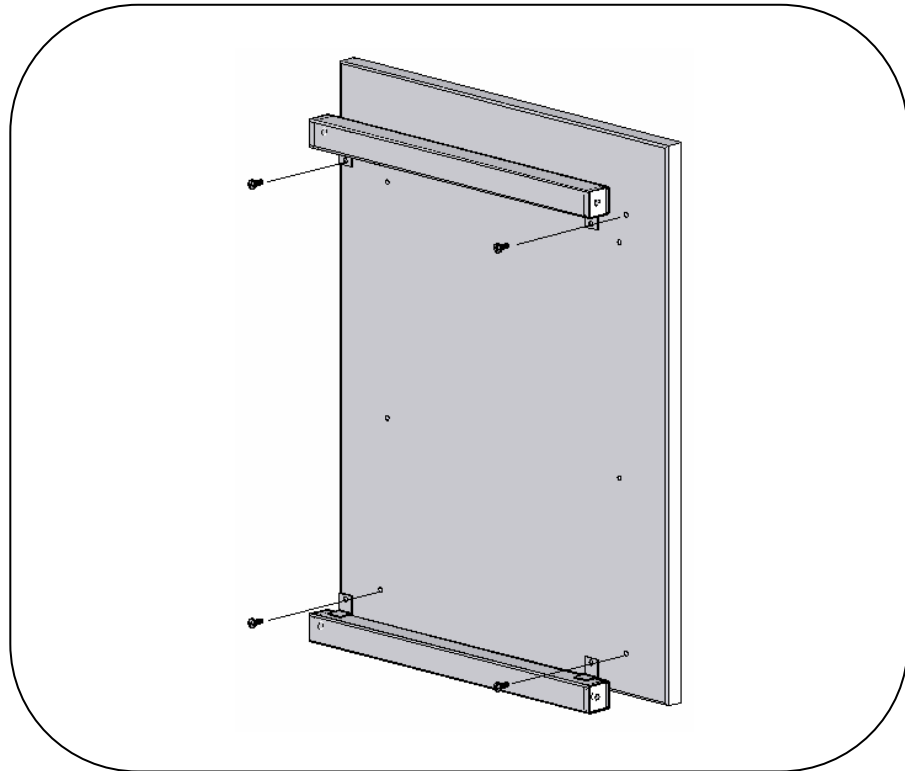

## Step 4. Assemble the Lower Shelf

Place the lower shelf so that the hardware inserts are facing up. Next, place two of the cross bars on the shelf lining up the holes on the shelf with the brackets on the cross bar. Insert (4) cross head screws but **DO NOT FULLY TIGHTEN**. You will notice that one of the crossbars will overlap the shelf. This feature will be used if you purchased the bottom add-on shelf.

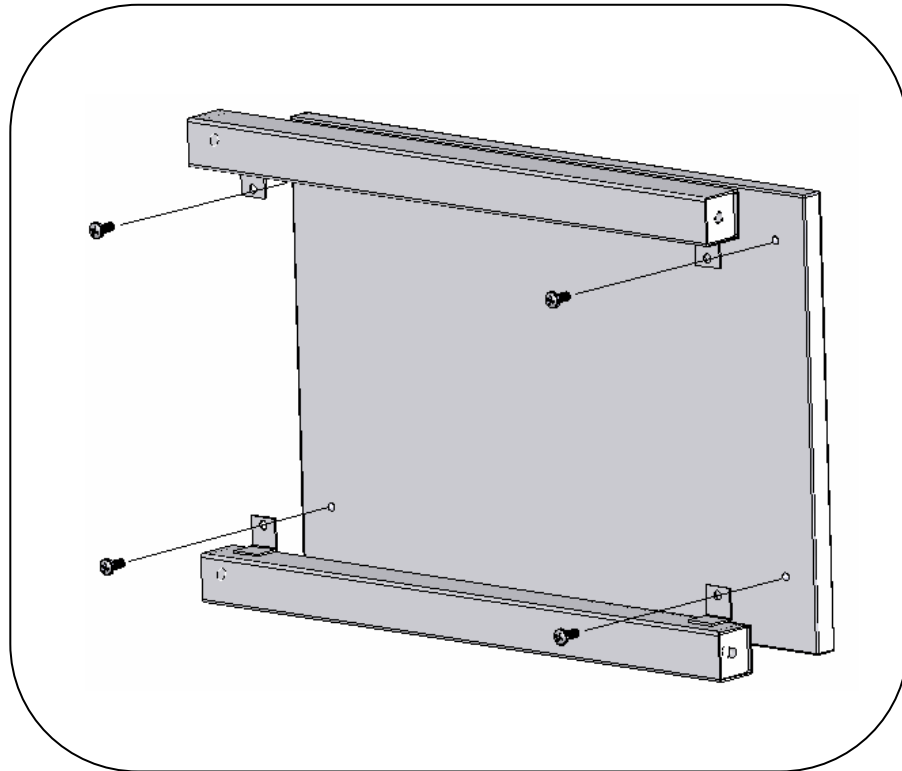

## Step 5. Frame Assembly

On this step you may want to have someone help you with the assembly. Attach the Lower shelf to left side with (2) 1 ½ Hex Drive Bolts. Next assemble the Right side in the same way. **DO NOT FULLY TIGHTEN YET.**

Screw in the (4) Levelers provided into the bottom of the frame (Not shown in the picture). If you purchased the optional caster kit, you may replace the levelers with the casters at this point.

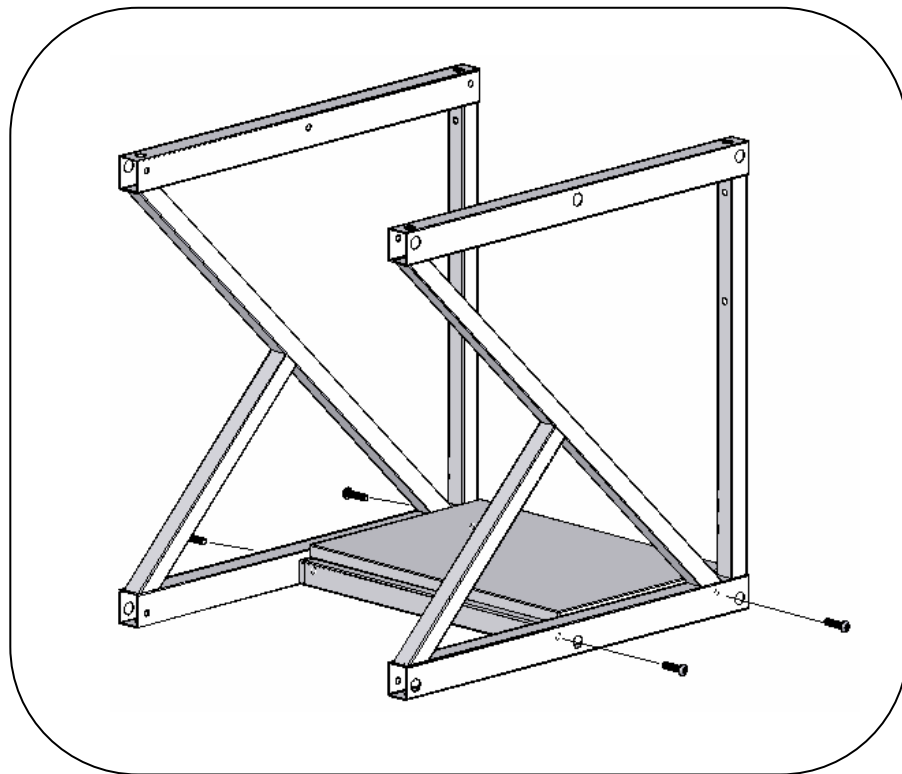

## Step 6. Attach the Work Surface

Stand the bench in its upright position and place the work surface on top of the bench. Attach work surface with (4) 1 ½ Hex Drive Bolts on each side. You may now tighten both the Hex Drive Bolts and the cross head screws on both the work surface and the lower shelf.

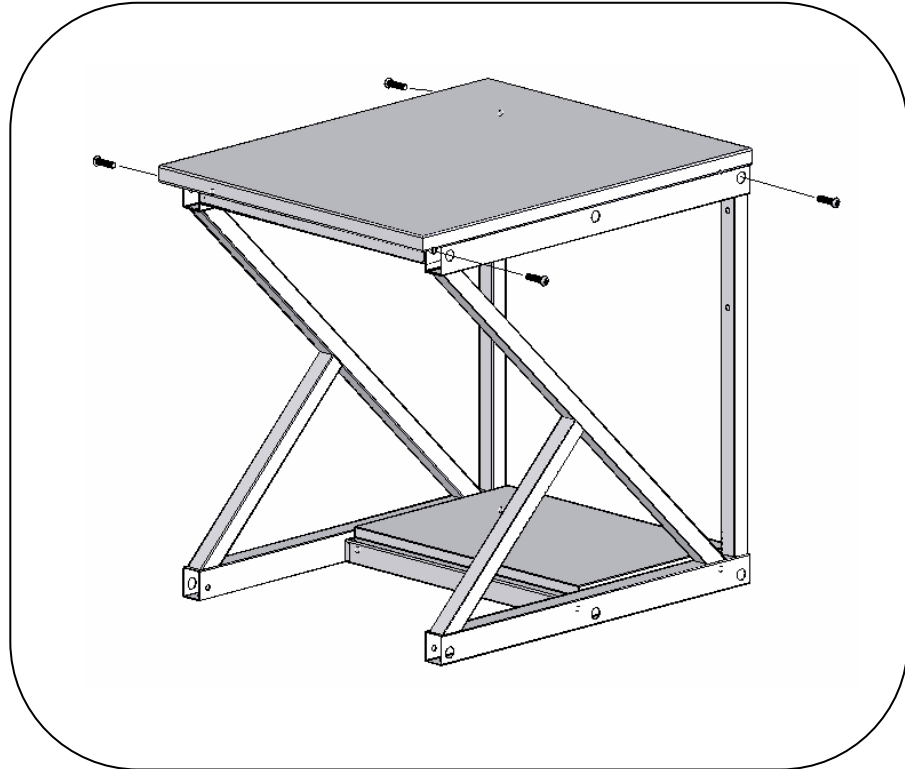

## Step 7. Attach Cable Tray and Shelf Channels

Place the Cable Tray/Shelf Support in the correct position and insert (4) 2 1/2" Hex Drive Bolts. Next, turn the Channel Nut onto each of the 4 bolts just until the nut is flush with the end of the bolt and pointing up. **IMPORTANT: MAKE SURE THAT THE GROOVES IN THE CHANNEL NUT ARE FACING THE BENCH.** There should be about 1" of space between the nut and the frame.

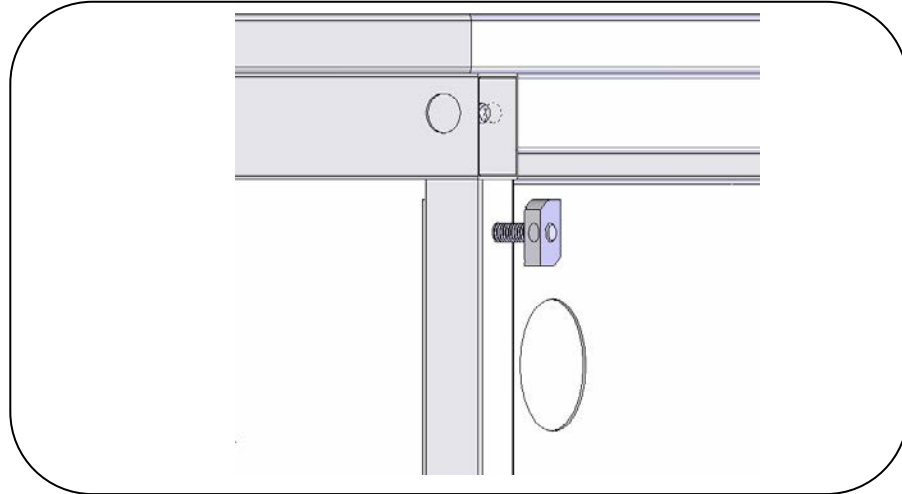

Hold the shelf channel over the (2) channel nuts while tightening the Hex Drive Bolts with T-Handle provided. As you tighten the bolts, the channel nuts will turn and lock into place. Make sure when completing this step that both channels are at the same height.

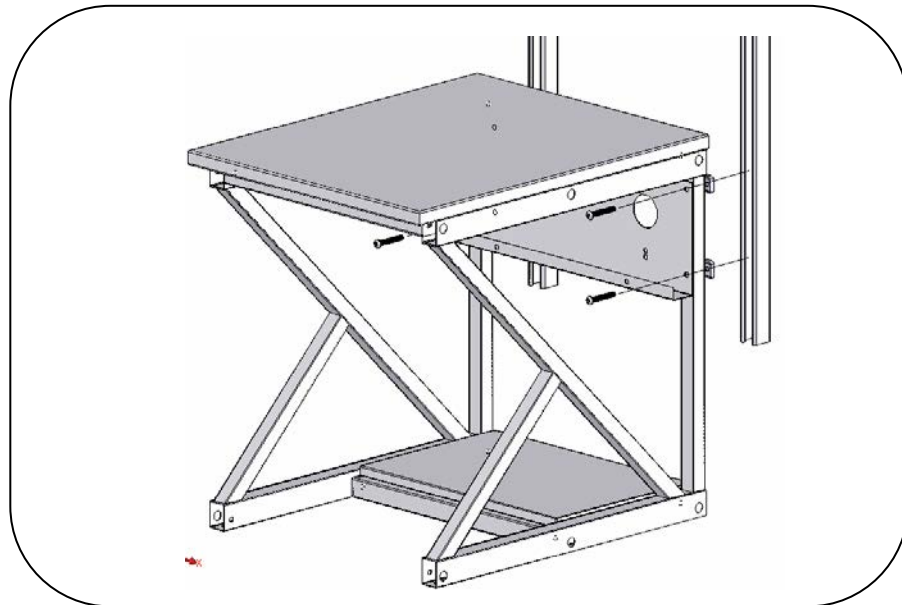



## Step 8. Attach Upper Shelves

Insert a 1 ½ Hex Drive Bolt into each shelf support hole and place a channel nut onto the bolt as you did for step 9. Remember to keep the hex bolt facing up and down. Place the shelf on the shelf channel with the channel nuts inside. Tighten the bolts and cross head screws. Make sure these bolts are very tight.

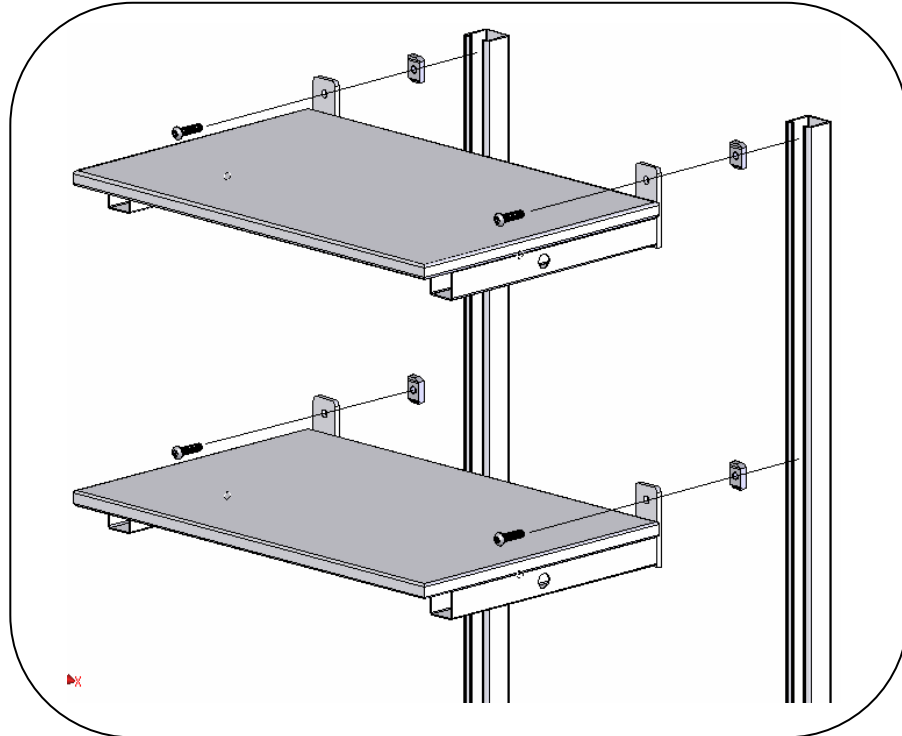

## Step 9. Add the Plastic End Caps

Insert the plastic end  $\frac{3}{4}$ " round caps into the left and right side frames as well as the upper shelf supports.

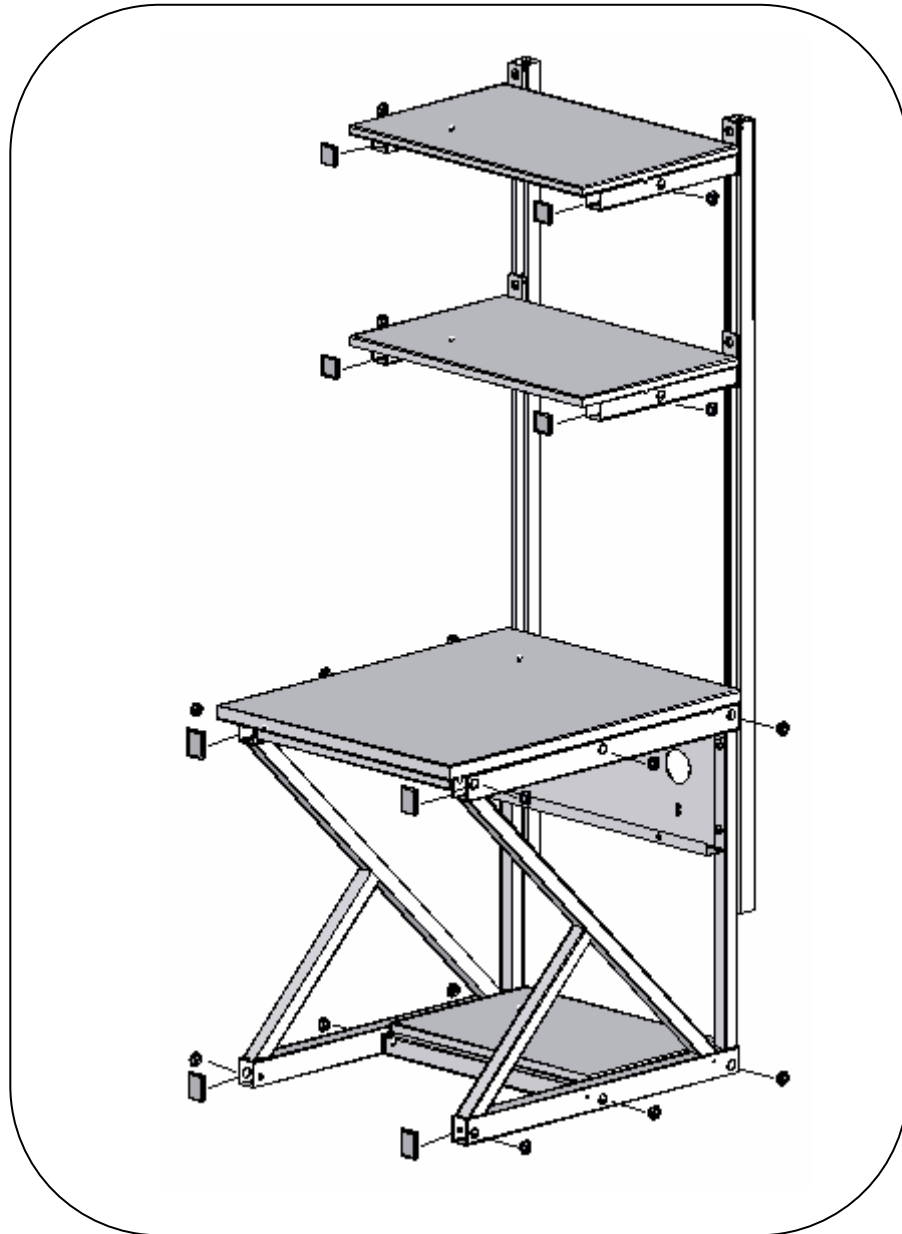

## Maintaining Your New Workbench

Your new Kendall Howard Performance Workbench is constructed with some of the highest quality materials available today. To keep your Workbench looking new, we recommend cleaning it regularly damp cloth using a mild soap and water solution.

- **Do not use abrasive cleaners.**
- **Keep work surface away from petroleum products**
- **Keep away from open flames. Shelving is constructed from a wood product and is not fire proof.**
- **If you opted for casters on your bench, moving the bench around may loosen the hardware over time. Periodically check that all bolts and screws are tightened.**
- **Do not exceed the weight thresholds for your bench. This could result in serious injury or death.**

# Limited Warranty

## **General:**

Under certain circumstances we offer with our products the following One Year Warranty Against Defects in Material and Workmanship. Please read your Warranty carefully. This Warranty sets forth our responsibilities in the unlikely event of defect and tells you how to obtain performance under this Warranty.

### ONE YEAR LIMITED WARRANTY AGAINST DEFECTS IN MATERIAL AND WORKMANSHIP

## **KENDALL HOWARD PRODUCTS COVERED:**

Performance Series LAN Benches and Workstations

## **Terms of Warranty:**

As provided herein, the Kendall Howard product is warranted to be free of defects in material and workmanship for a period of one year from the date of product purchase from Kendall Howard, not to exceed fifteen (15) months from the date of product manufacture. The date of purchase will be determined only from the Kendall Howard sales order acknowledgment. If any part or portion of the Kendall Howard product fails to conform to the Warranty within the Warranty period, Kendall Howard, at its option, will furnish new or factory remanufactured products for repair or replacement of that portion or part.

## **Warranty Extends to First Purchaser for Use, Non-transferable:**

This Warranty is extended to the first person, firm, association or corporation for whom the Kendall Howard product specified herein is originally sold for use in the United States (the "User"). This Warranty is not transferable or assignable without the prior written permission of Kendall Howard.

## **Assignment of Warranties:**

Kendall Howard assigns to User any warranties which are made by manufacturers and suppliers of components of the Kendall Howard product and which are assignable, but Kendall Howard makes NO REPRESENTATIONS as to the effectiveness or extent of such warranties, assumes NO RESPONSIBILITY for any matters which may be warranted by such manufacturers or suppliers and extends no coverage under this Warranty to such components.

## **Drawings, Descriptions:**

Kendall Howard warrants for the period and on the terms of the Warranty set forth herein that the Kendall Howard product will conform to the descriptions contained in Kendall Howard final invoices, orders, proposals (as modified) and other Kendall Howard descriptive documents ("Descriptions"). Kendall Howard does not control the use of any Kendall Howard product. Accordingly, it is understood that the Descriptions are NOT WARRANTIES OF PERFORMANCE and NOT WARRANTIES OF FITNESS FOR A PARTICULAR PURPOSE.

## **Warranty Claims Procedure:**

Within a reasonable time, but in no case to exceed ninety (90) days, after User's discovery of a defect, User shall contact Kendall Howard at 1-651-340-1400. Subject to the limitations specified herein, a Kendall Howard customer service representative will repair or replace the non-conforming Kendall Howard product warranted hereunder, without charge for materials. User will not be charged for labor if performed within ninety (90) days of product purchase. In all other instances, User will be charged for labor performed at Kendall Howard's then current rates. Kendall Howard shall assume shipping costs for replacement products and return of the defective product to Kendall Howard. Warranty coverage will be extended only after Kendall Howard inspection discloses the claimed defect and shows no signs of treatment or use which would void the coverage of this Warranty.

**Warranty Performance of Component Manufacturers:**

It is Kendall Howard's practice, consistent with its desire to remedy Warranty defects in the most prompt and effective manner possible, to cooperate with and utilize the services of component manufacturers and their authorized representatives in the performance of work to correct defects in the Kendall Howard components. Accordingly, Kendall Howard may utilize third parties in the performance of Warranty work, including repair or replacement hereunder, where, in Kendall Howard's opinion, such work can be performed in less time, and with less .

**Items Not Covered By Warranty:**

THIS WARRANTY DOES NOT COVER DAMAGE OR DEFECT CAUSED BY misuse, improper application, wrong or inadequate electrical current or connection, negligence, inappropriate on site operating conditions, repair by non-Kendall Howard designated personnel, accident in transit, tampering, alterations, a change in location or operating use, exposure to the elements, Acts of God, theft or installation contrary to Kendall Howard 's recommendations or specifications, or in any event if the Kendall Howard serial number has been altered, defaced, or removed.

THIS WARRANTY DOES NOT COVER installation costs, external circuit breaker resetting or maintenance or service items and further, except as may be specifically provided for herein, does NOT include labor or shipping costs arising from the repair or replacement of the Kendall Howard product, or any part thereof, or charges to remove same from any premises of User.

THIS WARRANTY IS VOID if User alters the product in any way.

**Limitations:**

- THIS WARRANTY IS IN LIEU OF AND EXCLUDES ALL OTHER WARRANTIES, EXPRESS OR IMPLIED, INCLUDING MERCHANTABILITY AND FITNESS FOR A PARTICULAR PURPOSE.
- USER'S SOLE AND EXCLUSIVE REMEDY IS REPAIR OR REPLACEMENT OF THE KENDALL HOWARD PRODUCT AS SET FORTH HEREIN.
- IF USER'S REMEDY IS DEEMED TO FAIL OF ITS ESSENTIAL PURPOSE BY A COURT OF COMPETENT JURISDICTION, KENDALL HOWARD'S RESPONSIBILITY FOR PROPERTY LOSS OR DAMAGE SHALL NOT EXCEED ONE TIMES THE NET PRODUCT PURCHASE PRICE.
- IN NO EVENT SHALL KENDALL HOWARD ASSUME ANY LIABILITY FOR INDIRECT, SPECIAL, INCIDENTAL, EXEMPLARY OR CONSEQUENTIAL DAMAGES OF ANY KIND WHATSOEVER, INCLUDING WITHOUT LIMITATION LOST PROFITS, BUSINESS INTERRUPTION OR LOSS OF DATA, WHETHER ANY CLAIM IS BASED UPON THEORIES OR CONTRACT, NEGLIGENCE, STRICT LIABILITY, TORT, OR OTHERWISE.

**Miscellaneous:**

- NO SALESPERSON, EMPLOYEE OR AGENT OF KENDALL HOWARD IS AUTHORIZED TO ADD TO OR VARY THE TERMS OF THIS WARRANTY. Warranty terms may be modified, if at all, only by a writing signed by a Kendall Howard officer.
- This Warranty is effective as of the date of Kendall Howard receipt of full payment and supersedes all previous warranties. Kendall Howard reserves the right to supplement or change the terms of this Warranty in any subsequent warranty offering to User or others.
- In the event that any provision of this Warranty should be or becomes invalid and/or unenforceable during the warranty period, the remaining terms and provisions shall continue in full force and effect.
- User shall complete the attached User Information Card and forward it to Kendall Howard within thirty (30) days of receipt of the Kendall Howard product.
- This Warranty is given in and performance hereunder is to be construed under the laws of the State of Minnesota.
- This Warranty represents the entire agreement between Kendall Howard and User with respect to the subject matter herein and supersedes all prior or contemporaneous oral or written communications, representations, understandings or agreements relating to this subject.

