

OUTDOOR ENCLOSURE 900 SERIES NEMA



Width 27.5" - Depth 24"

Features:

- ▶ Designed to provide a degree of protection for enclosed equipment against falling dirt, rain, snow, sleet, windblown dust, splashing water, hose-directed water and corrosion.
- ▶ Includes casters for easy mobility.
- ▶ Features fully adjustable internal cage nut rails for #12-24 mounting screws in EIA universal spacing.
- ▶ Leveling feet included.
- ▶ Galvanized steel construction.
- ▶ Meets or exceeds NEMA 250 - protection 4X and EIA310D.
- ▶ Finished with textured polyester material-highly corrosion resistant.



Ventilation



Leveling Feet



Anchoring

ENVIRONMENTAL CONDITIONS	TYPE OF PROTECTION				
	3	3R*	3S	4	4X
Incidental contact with enclosed equipment	■	■	■	■	■
Rain, snow and sleet	■	■	■	■	■
Sleet			■		
Windblown dust and falling dirt	■		■	■	■
Hose-directed water				■	■
Corrosion					■



OUTDOOR ENCLOSURE 900 SERIES NEMA

Width 27.5" - Depth 24"

Angled Cover



Prevents corrosion and water intrusion.

Hermetic Seal



Prevents water leaking into the unit protecting the enclosed equipment.

Filters



Protects equipment from potential contamination agents.

Ventilation



Allows air flow ventilation and hot air evacuation in the enclosure.

Adjustable Rails



Features fully adjustable cage nut rails for #12-24 mounting equipment screws.

External Protection



Rain



Snow



Outdoor conditions



OUTDOOR ENCLOSURE 900 SERIES NEMA



Width 27.5" - Depth 24"

Specifications					AWG			
Stock No.	RU	Height	Format	Color	Structure	Cover	Doors	Base
OE9019-20-04	20 RU	3'	19"	Gray	16	16	18	14
OE9019-28-04	28 RU	4'	19"	Gray	16	16	18	14
OE9019-34-04	34 RU	5'	19"	Gray	16	16	18	14
OE9019-40-04	40 RU	6'	19"	Gray	16	16	16	14
OE9019-45-04	45 RU	7'	19"	Gray	16	16	16	14

RU = Rack Units

External Dimensions

Product					Package			
Stock No.	A - Height	B - Width	C - Depth	Load Capacity	Height	Width	Depth	Shipping Weight
OE9019-20-04	3'	27.5"	24"	580 lbs	48"	28"	25"	188 lbs
OE9019-28-04	4'	27.5"	24"	650 lbs	62"	28"	25"	250 lbs
OE9019-34-04	5'	27.5"	24"	700 lbs	72"	28"	25"	310 lbs
OE9019-40-04	6'	27.5"	24"	730 lbs	83"	28"	25"	375 lbs
OE9019-45-04	7'	27.5"	24"	780 lbs	91"	28"	25"	438 lbs

Internal Dimensions

Product				
Stock No.	A - Height	B - Width	C - Depth	Load Capacity
20 RU	28"	24"	22.5"	580 lbs
28 RU	43"	24"	22.5"	650 lbs
34 RU	52"	24"	22.5"	700 lbs
40 RU	64"	24"	22.5"	730 lbs
45 RU	74"	24"	22.5"	780 lbs

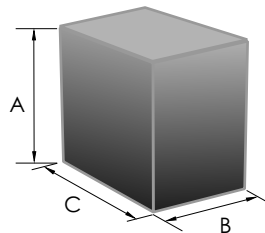
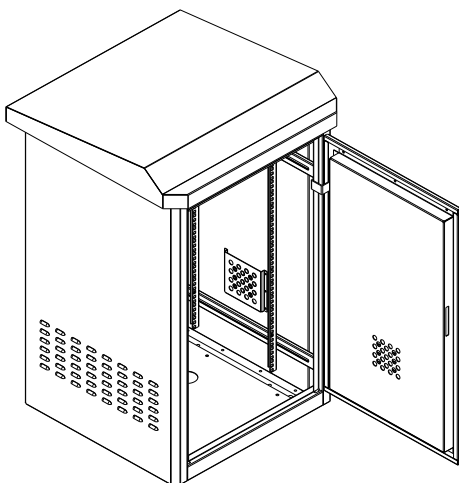

Colors:



Gray

Custom colors and configurations available. Minimum quantities apply.