

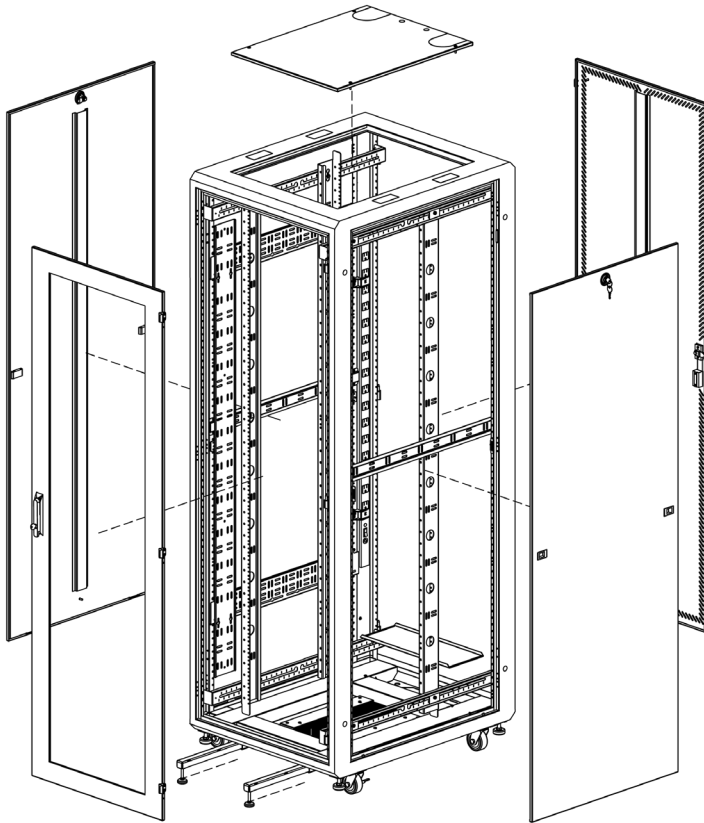

E Series Cabinets
Installation Instructions
(UL60950-1/UL2416 E Series Equipment Cabinet/Rack)



GreatCabinets.com

1.866.879.4522

Instructions for the following Great Lakes Cabinets:
GL720E-2432, GL720E-2436, GL720E-2932, GL720E-2936, GL840E-2432,
GL840E-2436, GL840E-2932, GL840E-2936

PREFACE

This manual is provided to prevent service personnel from committing an act that results in the risk of fire, electric shock, or injury to persons. Only trained service personnel should receive, unpack, and assemble the E Series Cabinets. In addition, only trained service personnel should install equipment in cabinets.

SAFETY SYMBOLS USED IN THIS MANUAL

This manual provides general safety guidelines to be observed during installation, operation, and maintenance of the E Cabinet.



WARNING: Failure to follow directions in the warning could result in injury to persons or loss of life.



CAUTION: Failure to follow directions in the caution could result in damage to equipment or storage data.

SAFETY CONSIDERATIONS



WARNING: Improper handling and use of the E Cabinet could result in equipment damage, serious injury, or possible death.

Only trained service personnel should be used to remove the cabinet from the pallet. Also, be sure you have a sufficient number of service personnel. Do not attempt to move cabinets by yourself.

Only UL® Listed ITE (Information Technology Equipment) units should be installed inside the E Cabinet.

Be sure to read and follow all individual manufacturer equipment manuals for safety and installation instructions.

Proper spacing is required when installing electrical equipment to avoid electrical shock. Maintain minimum spacing between the accessories and components and the computer cabinet assembly for safe operation of the equipment when installed in accordance with the National Electric Code ANSI/NFPA 70-1999.

The ambient temperature operating range for the E Cabinet and accessories is +50 to +95° F (+10 to +35° C).

The non-operating temperature is -4 to +140° F (-20 to +60° C).

SERVICE

The E Series Cabinet should be repaired by personnel trained by Great Lakes, or returned to Great Lakes for repair or replacement. Contact Great Lakes Technical Support at 814.734.7303 or at GreatCabinets.com

WHAT'S INCLUDED

- E unit (assembled)
- Keys as needed (depending on configuration)
- (50) M6 cage nuts (3/8" square) and M6 screws (#10-32 tapped rails available, must be specified at time of order)
- This user's manual

This user's manual applies to the following Great Lakes cabinets:

Part No.	H	W	D	RMU
GL720E-2432	72	24	32	37
GL720E-2436	72	24	36	37
GL720E-2932	72	29	32	37
GL720E-2936	72	29	36	37
GL840E-2432	84	24	32	44
GL840E-2436	84	24	36	44
GL840E-2932	84	29	32	44
GL840E-2936	84	29	36	44

E weight capacity: 1500 lbs.

INSTALLATION

Receiving, Unpacking, and Removing the E Series Cabinet from the Pallet

Inspect and report any damage before receiving. Unpack the cabinet by carefully removing the corrugated carton and corners. Avoid damaging the cabinet when removing packaging.



WARNING: Only trained service personnel should be used to remove the cabinet from the pallet. Also, be sure you have a sufficient number of service personnel. Do not attempt to move cabinets by yourself.



WARNING: Be careful when moving cabinets before installation. Sudden stops and starts, excessive force, obstructed routes, and uneven floor surfaces may cause the cabinet to topple over.

Loading Equipment



WARNING: Only install equipment after the E Cabinet has been properly secured. Do not move the E Cabinet assembly while loaded.

Once in place at the desired/intended location, deploy the leveling feet for maximum stability.

Rated or maximum load capacity for the E Cabinet is 1500 pounds on the floor or on leveling glides.

To maintain a uniform distribution of the mechanical load in the E Cabinet, load the heaviest equipment first, at the bottom of the E Cabinet and load the lighter units at the top.

OPERATING DOOR HANDLE

The door swing handles have been installed and no additional assembly is required. To operate the swing handle, lift up at the bottom of the handle to open. Swing the handle to the left or right to open.

The handle must be kept in this position to close the door. Return the handle to the initial position and use the key provided to lock the handle. The lock on the side panels will accept the same key. The swing handles and doors are reversible. The exploded view shows its construction.

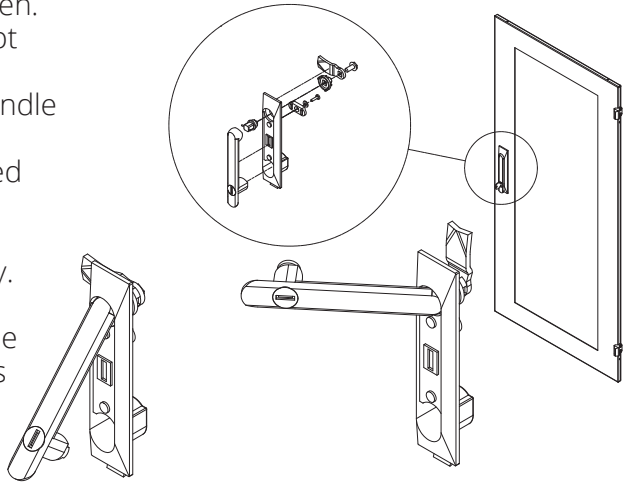

INTERCHANGING DOOR HANDLES

Door handles on all doors can be interchanged with any one of Great Lakes optional swing handles: CH-02 (three-digit combination lock and key); CH-03 (padlock with key lock); or CH-04 (padlock). When interchanging the handle, the type of door will determine the type of cam that is required to properly install the handle; when ordering the handle, Great Lakes will determine if additional cams are required.

ASSEMBLY OF SWING-LATCH HANDLE ON CONTOUR MESH DOOR

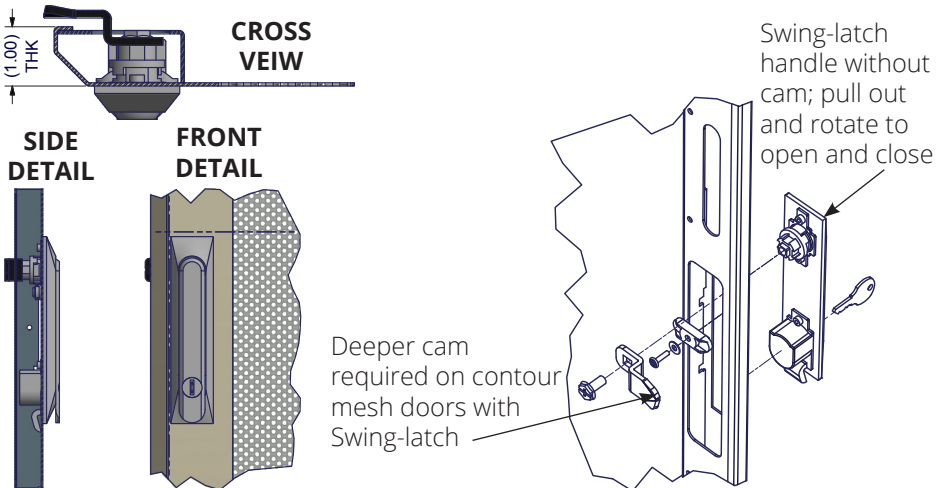

ASSEMBLY OF SWING-LATCH HANDLE ON ALL OTHER DOORS: STANDARD MESH, STEEL, PLEXIGLAS AND PERIMETER VENTED DOORS

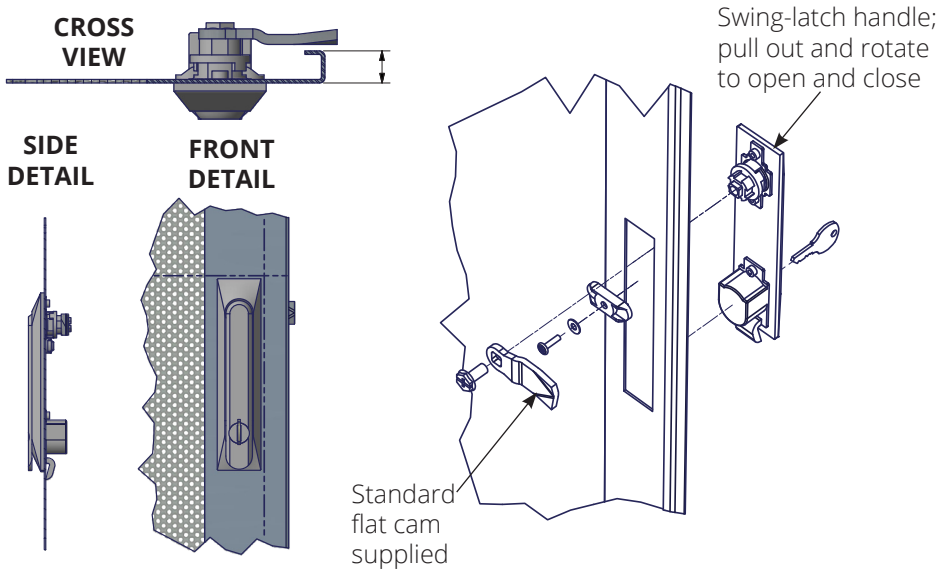

30"W contour mesh doors come standard with easy-latch (slam) handles. Door handles on 24"W contour mesh doors and all other 24" and 29/30"W doors can be replaced with the easy-latch (slam) handle. When interchanging the door handle, the type of door will determine the type of cam that is required to properly install the handle; when ordering the handle, Great Lakes will determine if additional cams are required. *Please note: The easy-latch (slam) is not compatible with 3 point latching (split doors).*

ASSEMBLY OF EASY-LATCH (SLAM) HANDLE ON CONTOUR MESH DOORS

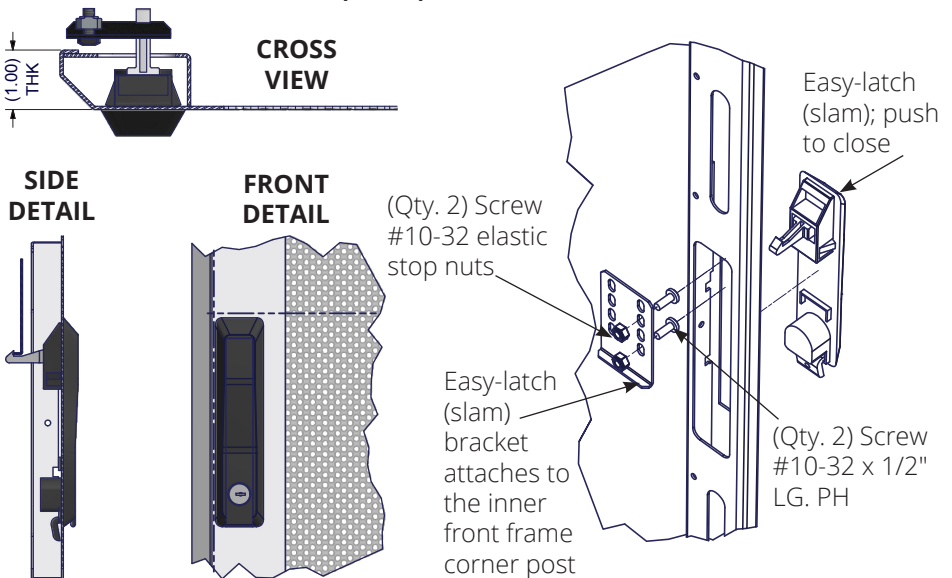

**ASSEMBLY OF EASY-LATCH (SLAM) HANDLE ON ALL OTHER DOORS:
STANDARD MESH, STEEL, PLEXIGLAS AND PERIMETER VENTED DOORS**

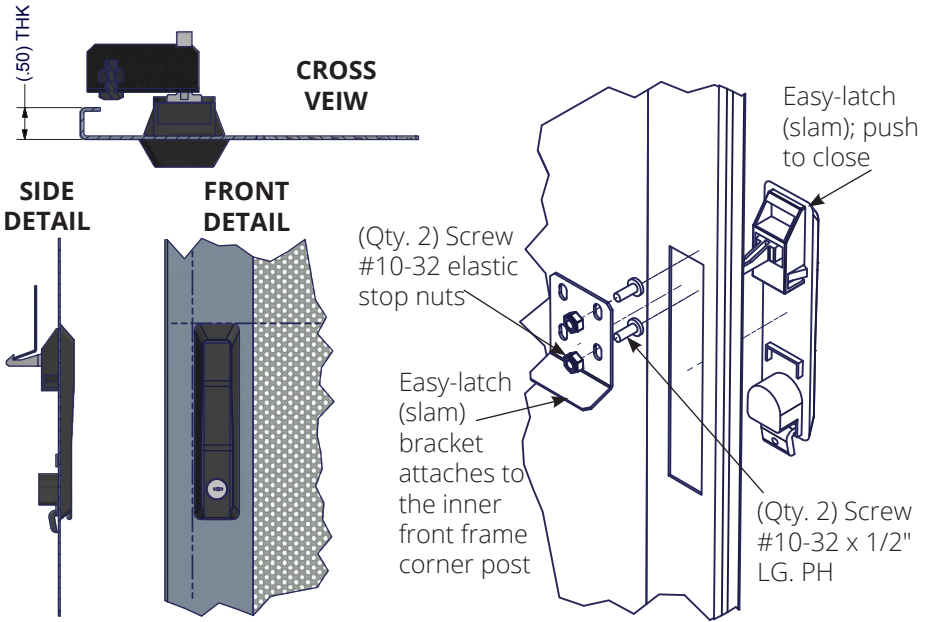

DOOR REMOVAL AND ATTACHMENT

Before removing the door, pull apart the quick disconnect grounding wires. Open the door beyond 90 degrees, grasp the door with both hands and carefully lift upward. When the door is free of all three hinge pins, pull the door away from the cabinet. To attach the door, align all three hinges of the door to their respective hinge pins on the cabinet and slowly slide the door down until seated.

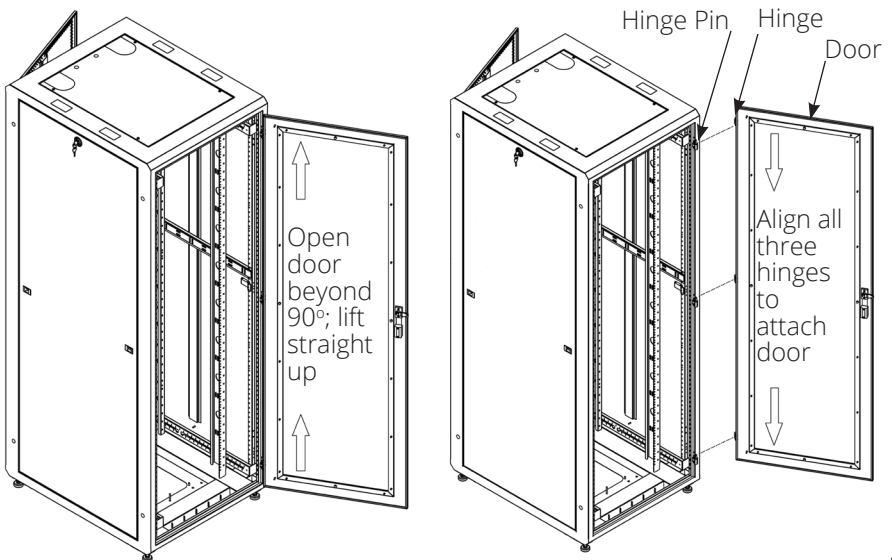

FIELD REVERSIBLE FRONT & REAR DOORS

The front and rear doors are installed right hand hinged as standard from the manufacturer. Removing the hinges allows you to reverse the door by flipping them over and reinstalling the hinges using the universal mounting holes. Begin both screws, then tighten while maintaining perfect vertical alignment. See detail below. All cabinet frames and doors have provisions to be hinged right or left hand. If the door is reversed, the handle must be taken out, rotated 180°, and installed in the door again. See Operating Handle on page 5.

HINGE MOUNTING

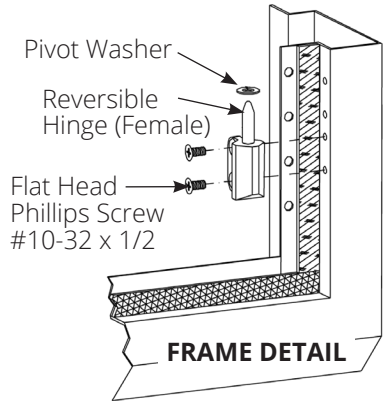
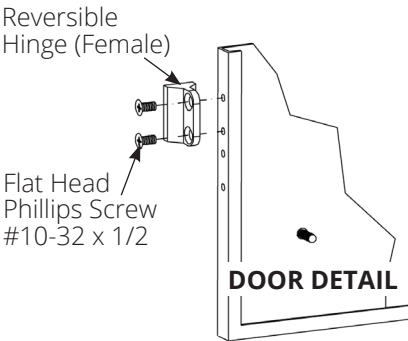

SIDE PANEL REMOVAL

Before removing the side panel, pull apart the quick disconnect grounding wires. The side panels are secured to the cabinet frame with two quick release latches and a keyed lock. Be sure to unlock the side panel. To remove the side panel, squeeze the quick release latches towards each other. Then tilt the top of the side panel out slightly and lift the side panel up a couple of inches until it is free. To install the side panel, reverse the process. Make sure the slots on the side panel engage with the two tabs at the bottom of the frame.

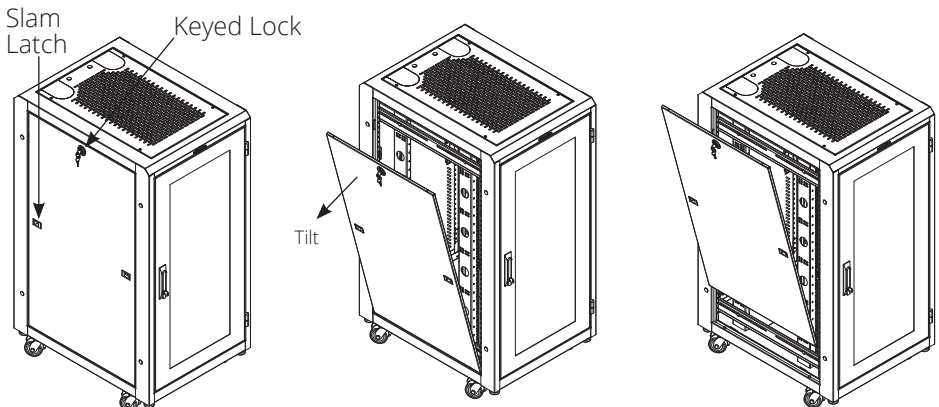

CASTER AND LEVELER MOUNTING



CAUTION

- To install casters or levelers the cabinet must be tipped onto its side. The cabinet can be very heavy; several people will be required in this process. Please practice safe lifting techniques.
- DO NOT lay the cabinet on its front or back, this may damage the door hinges.
- Removing doors and sides will help reduce the weight of the cabinet.
- Before tipping, remove the side panels to prevent damage to the locks and latches.

ADJUSTABLE LEVELER MOUNTING

On the bottom of the cabinet there are eight threaded holes, two in each corner. The outside holes are threaded 1/2"-13 thds. and will accept the levelers. Once the levelers (7209-HD or 7209-4HD) are installed, the cabinet level can be adjusted with the use of a 5/8" open wrench when adjusting from the outside or a 3/8" closed wrench/socket when adjusting from the inside.

ANCHOR MOUNTING THRU HOLE

The middle .75 dia. thru holes are for securing the cabinet to the floor. These holes will accept a standard concrete anchor if desired; the Seismic Anchor Kit (AK101) is suggested.

CASTER MOUNTING

The four inside holes in each corner are threaded 1/2"-13 thds. to accept the casters. *Be sure to thread the caster into the bottom of the cabinet until it is firmly seated.*

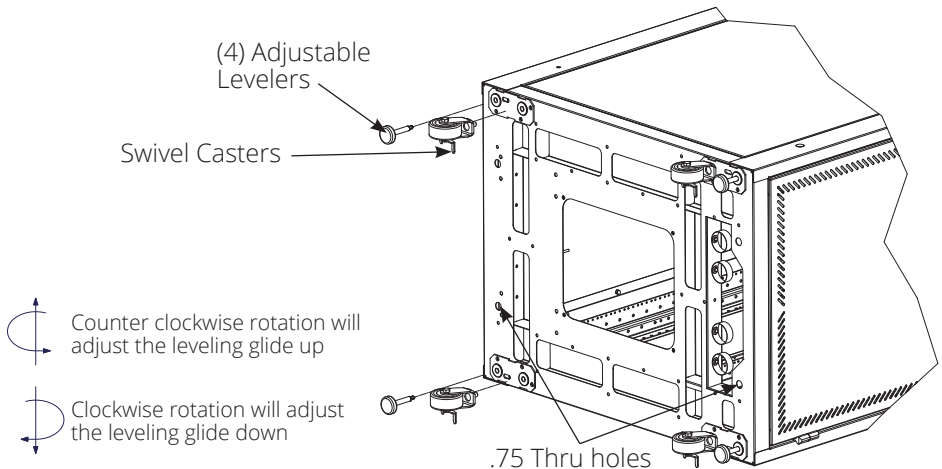

TOP PANEL MOUNTING

The top panel of the cabinet is installed at the manufacturer. Removing the top panel can be done by removing the four #10-32 x 1" lg. phillips pan head screws. Then simply lift the top panel out or off.

Top panels are available for 24"W (TPE-24) and 29"W (TPE-29) E Series Cabinets. There are 5 options for E Cabinets:
 ** indicates cabinet width in part number

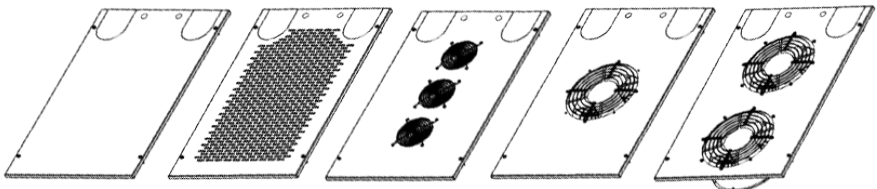
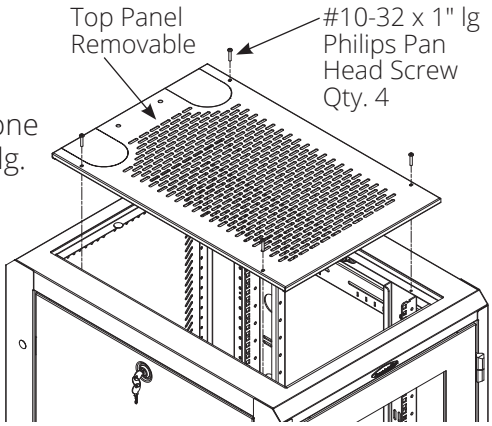

TPE-S**
Solid

TPE-P**
Perforated

TPE-F**
Three,
75 CFM Fans

TPE-F10**
One, 10" 550
CFM Fan

TPE-2F10**
Two, 10" 550
CFM Fans

BOTTOM PANELS

There are several styles of panels available for the bottom of your E Series cabinet. Optional panels are solid, filtered or brush grommet. These panels have foam gasketing for a positive seal and mount to four internally threaded studs using #10-32 x 1/2" lg. phillips pan head screws. The back opening can be covered with a solid metal cover. These covers are specific to the width of the cabinet.

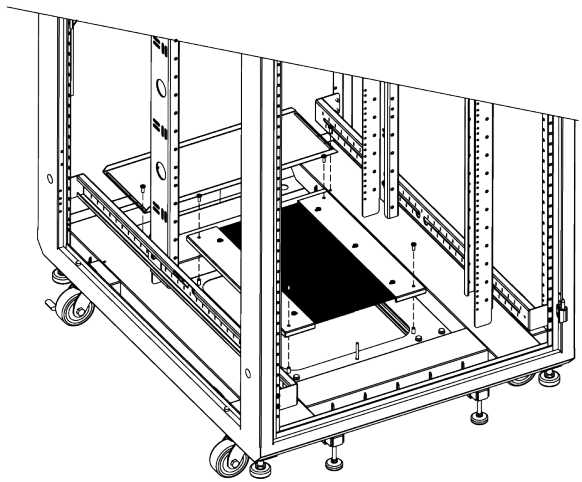

MOUNTING RAILS

The vertical mounting rails (each cabinet has two pairs, 12 ga. steel, powder coated rails), come installed with all standard frames at 19" EIA 310-E. The 29"W E cabinet can be configured to 23" EIA mounting with an optional replacement bracket set. Universal cage nut rails (M6) are standard. Tapped #10-32 rails are available (must be specified at time of order).

Rack Mount Units (RMU) are marked on rails for easy equipment mounting. Flexible Mounting Profile (FMP), round cable pass through holes, and vertical and horizontal cable tie down slots can be found on side of rails.

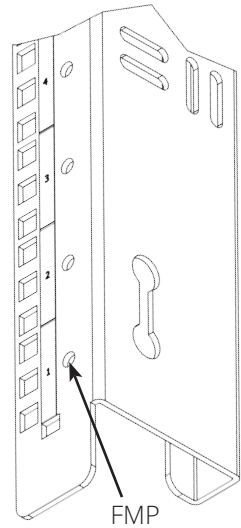

RAIL ADJUSTMENT

Rails are attached using a sliding nut plate and a 1/4"-20 hex head bolt. By loosening the top and bottom bolts with a 3/8" drive socket, the rails can be adjusted infinitely front and back.

Do NOT attempt to adjust rails once equipment has been loaded.

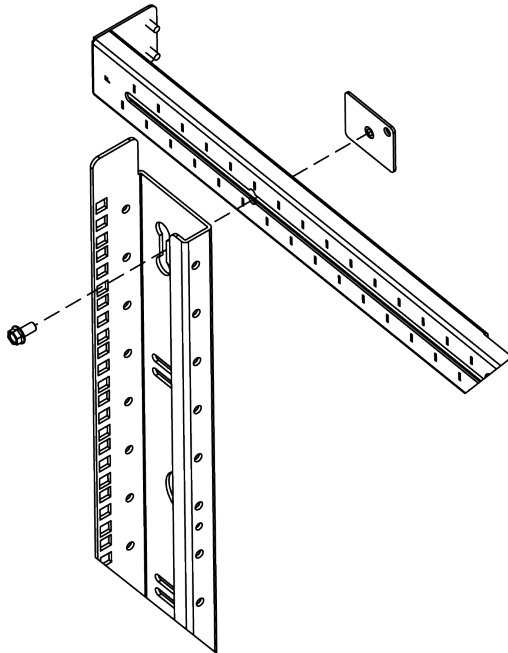

STANDARD POWER STRIP MOUNTING

For your convenience, we have provided mounting brackets in the left rear and right rear corners of the cabinet for mounting power strips vertically.

Typically, any power strip shipped with an cabinet will be installed at the manufacturer. To install a power strip in the field, remove the #10-32 x 1/2" screws that secure the bracket to the frame. Place the power strip into the corner post of the frame and then place one bracket between the top two outlets and install the #10-32 x 1/2" screw into the threaded hole in the frame. Then place the other bracket over the power strip between the bottom two outlets and secure to the frame with the same type of screw.

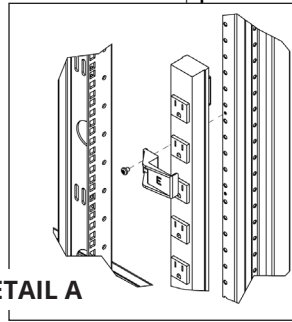
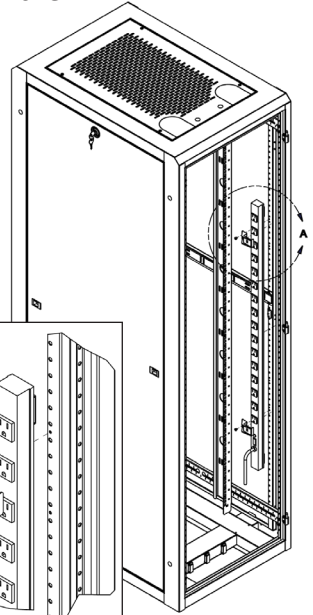

POWER

When using power distribution units (PDUs), each PDU should be connected to a committed branch circuit that is rated for the continuous load of all the equipment connected. When not using a PDU, each piece of equipment should be connected to a dedicated branch circuit.

OPTIONAL ACCESSORIES

UNIVERSAL POWER STRIP BRACKETS

Great Lakes offers a universal power strip bracket kit. These brackets allow you to mount a PDU with button mounting. See drawing.

Part No. PSBKE
- E Series PDU
Brackets

Spring Clips

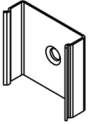

Tinnerman Clips



10/32 Nut with Lock Washer



10/32 x 3/8" Flat Head Screw



10/32 x 1/2" PanHead Screw

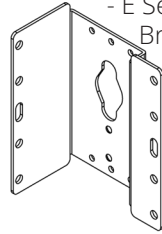

	PDU Bracket	Spring Clip	Tinnerman Clip	10/32 Nut w/Lock Washer	10/32 x 3/8" Flat Head Screw	10/32 x 1/2" Pan Head Screw
PSBKE	2	2	10	10	10	10

To mount Universal Power Strip Brackets in an E cabinet or cabinet extension, measure the required mounting distance top to bottom, install brackets, then install power strip.

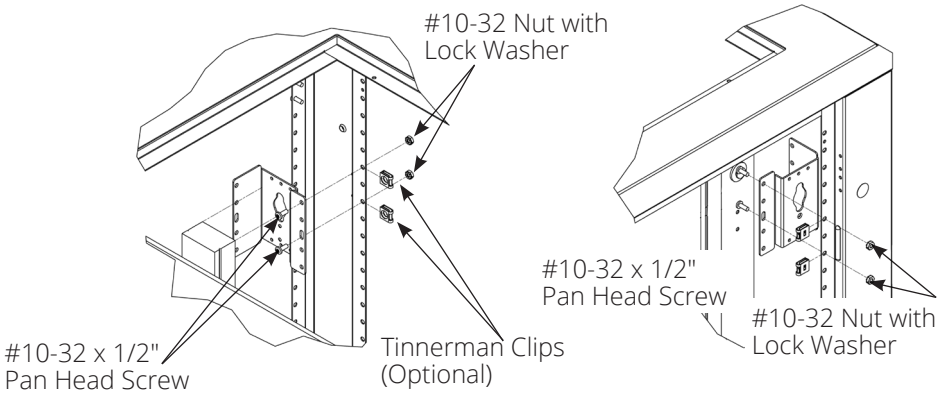

MOUNTING IN A CABINET EXTENSION

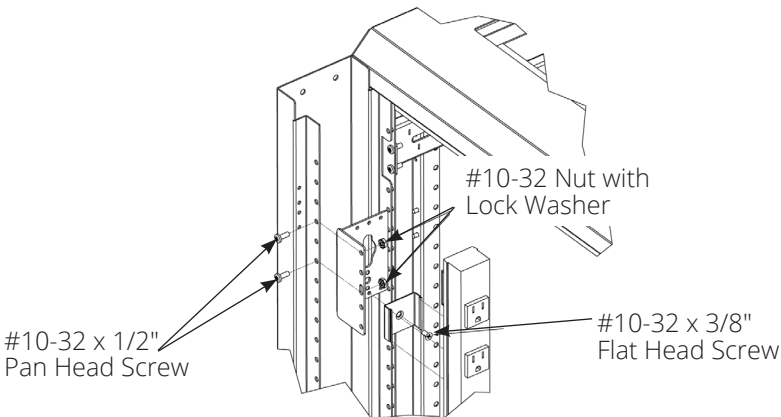

PLASTIC CABLE MANAGEMENT FINGERS

The CM-47 is a single section of 7 RMU "fingers" that mounts to the Flexible Mounting Profile (FMP) of cabinet rails. The ESC-K12 is a kit of 12 sections and the ENC-K24 is a kit of 24 sections. Fingers can be installed on the front or rear rails, but front rails must be recessed 4.5" for proper installation. It is recommended that each CM-47 be installed using 3 points of attachments. *Note: Installation drawing is shown in a Great Lakes ES Cabinet. Installation in a Great Lakes E Cabinet is identical.*

ESC-K12 Cable Management Rail Kit

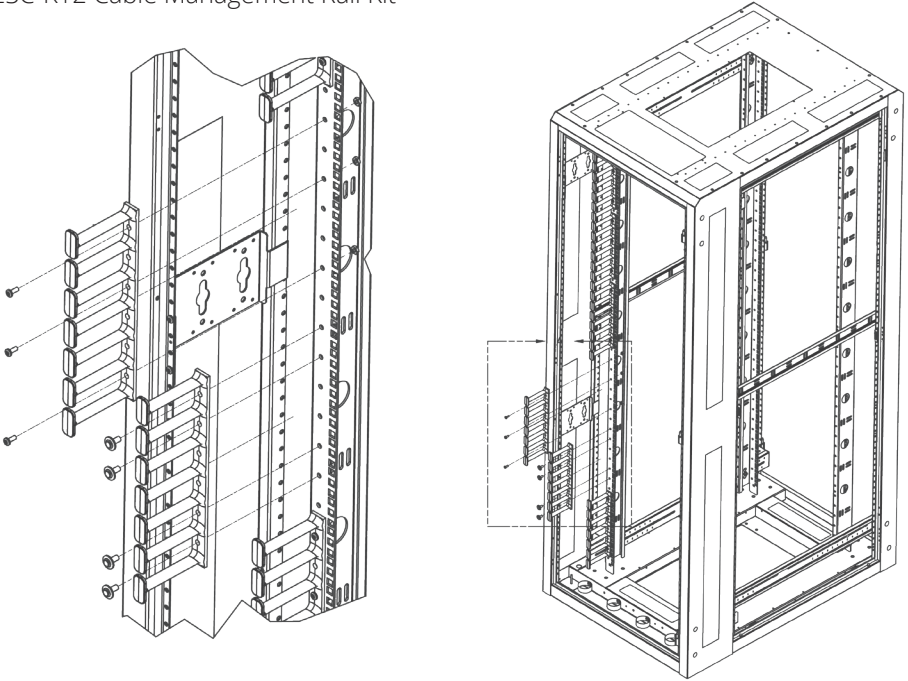

CABLE MANAGEMENT BAR KITS

Vertical cable management bar kits include two horizontal cable bars (HCB) and one vertical cable bar (VCB). When ordered with an cabinet, these kits will come pre-installed. Cable bars run independently from 19" mounting rails and are infinitely adjustable front to back.

Single vertical and horizontal cable bars are also available. Additional horizontal bars can be installed alone (without a vertical bar), or in conjunction with a kit. Additional vertical bars can only mount when at least two horizontal bars are already installed. Refer to Detail A for installation of horizontal and vertical bars.

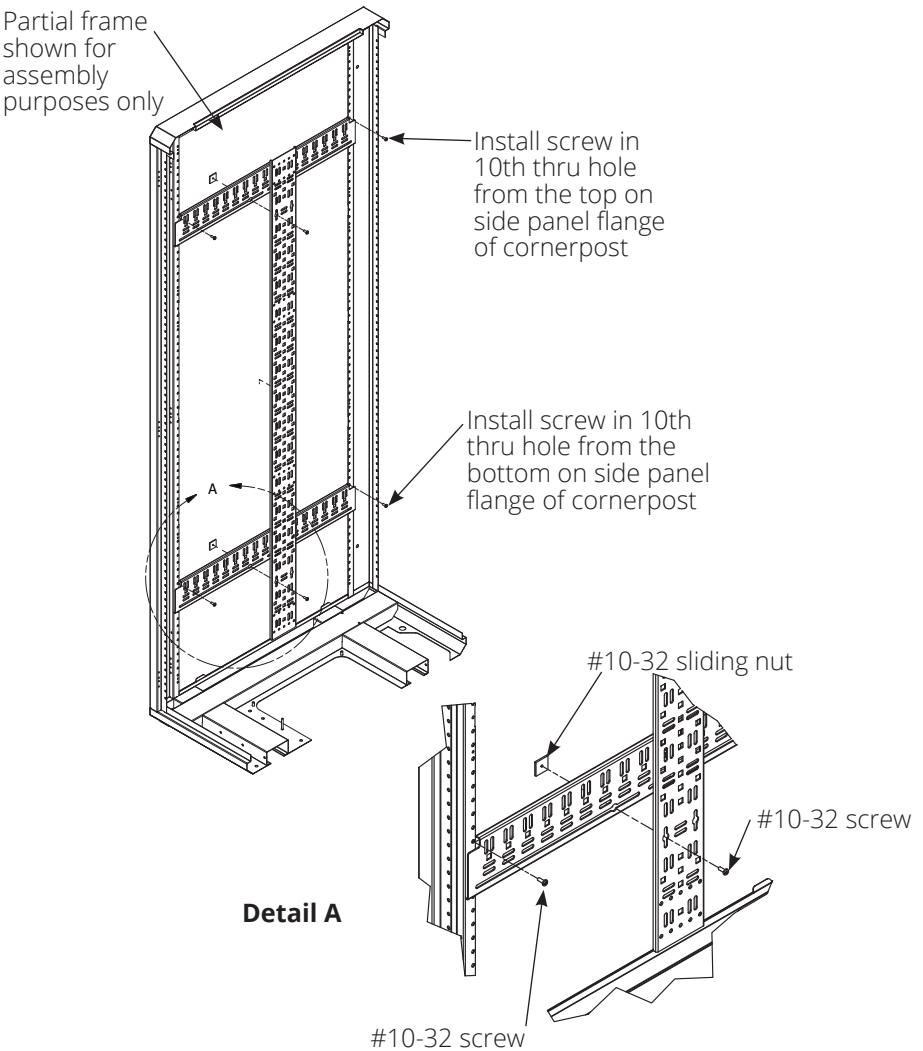

CABLE MANAGEMENT BAR KITS (continued)

All cable management bars are designed with a square hole pattern that is able to accept optional ¼ turn "D" rings. There are two sizes of "D" rings, both available in kits of 10. Actual location of "D" rings may vary based on customer desired location for installation. Refer to Detail B for installation of "D" rings.

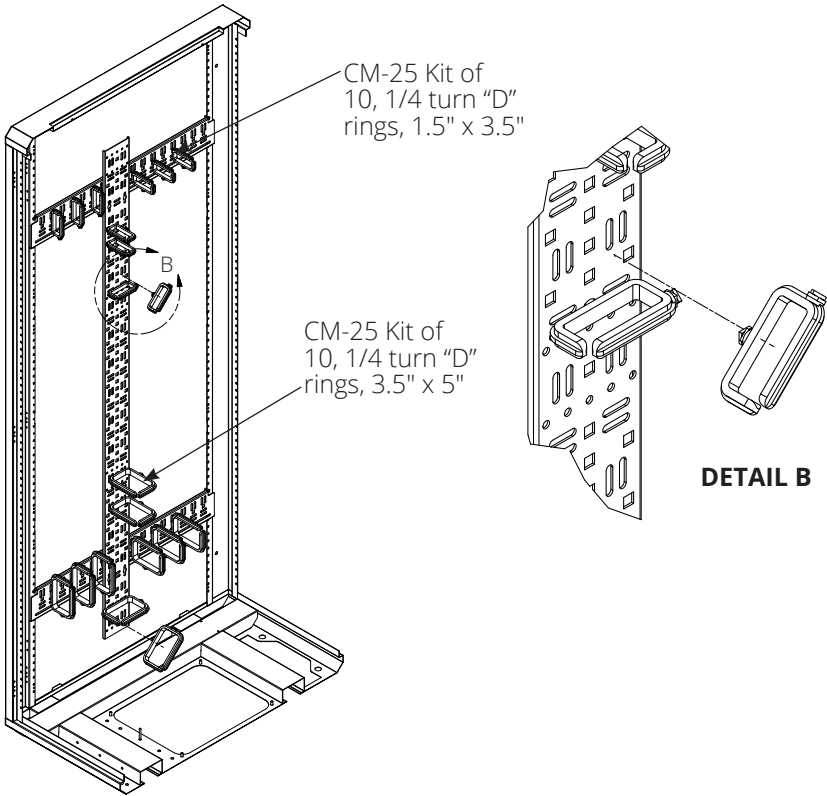

Available Cable Management Bar Kits and Ring Kits include:

VCB-7232	Cable Management Bar Kit for 720E-32 cabinet
VCB-7236	Cable Management Bar Kit for 720E-36 cabinet
VCB-8432	Cable Management Bar Kit for 840E-32 cabinet
VCB-8436	Cable Management Bar Kit for 840E-36 cabinet
VCB-72*	Single Vertical Cable Bar for 72"H cabinet
VCB-84*	Single Vertical Cable Bar for 84"H cabinet
HCB-32	Single Horizontal Cable Bar for 32"D cabinet
HCB-36	Single Horizontal Cable Bar for 36"D cabinet

CM-25 Kit of 10 x ¼ turn "D" rings, 1.5" x 3.5"

CM-26 Kit of 10 x ¼ turn "D" rings, 3.5" x 5"

**Note: Single vertical bars can only be installed when at least two horizontal bars are installed.*

ZERO RMU MOUNTING, ZR1 & ZR2

Both ZR bracket kits fit on the 29"W E cabinet. These allow for "0" RMU (outside of the EIA rail pattern) mounting of 19" rack mount power strip units or other 1 or 2 RMU equipment (such as patch panels). Install the bracket onto the rail or post toward the side panel. It is important to ensure you have 18.31" between the inner holes for 19" mounting.

Note: Installation drawing is shown in a Great Lakes ES Cabinet. Installation in a Great Lakes E Cabinet is identical.

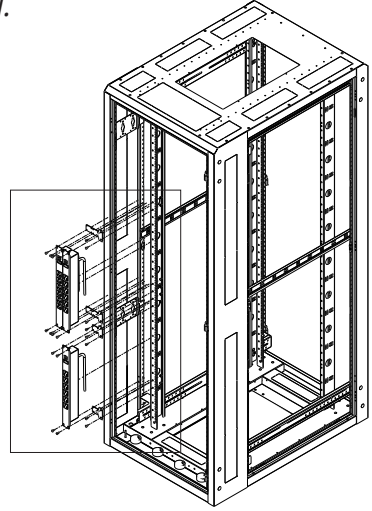
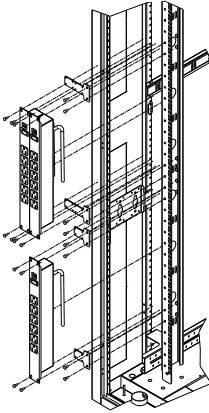

PDU1 MOUNTING

The 29"W E allows for "0" RMU mounting of 19" rack mount power strip units or other 1 RMU equipment (such as patch panels). You can mount up to twelve (12), 1 RMU pieces of equipment this way. Install the bracket into the side panel flange. Make sure you have 18.31" between the inner holes. (See detail B.) *Note: Installation drawing is shown in a Great Lakes ES Cabinet. Installation in a Great Lakes E Cabinet is identical.*

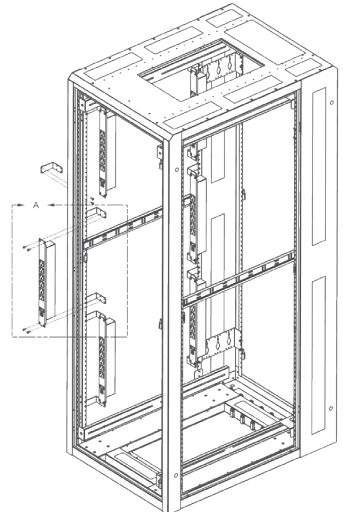
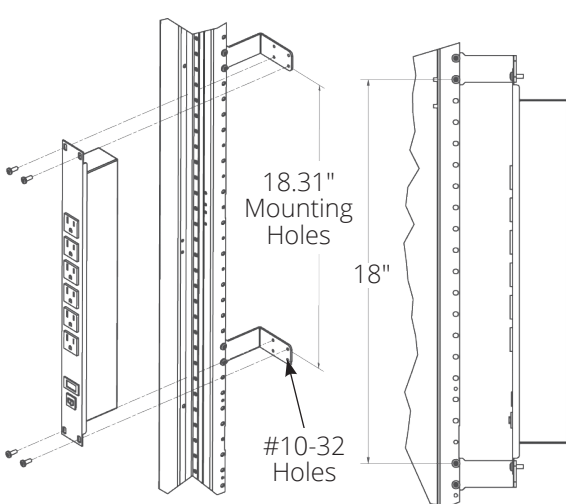

NETWORKING/GANGING

Cabinets can be networked using the following Great Lakes networking/ganging kit:

G101 Networking/Ganging Kit to gang two E Cabinets (pictured); no tools required

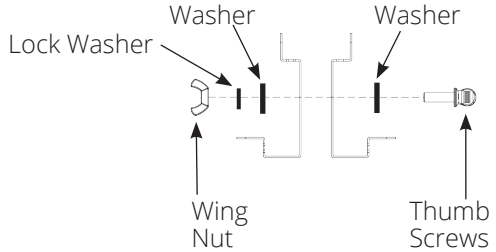
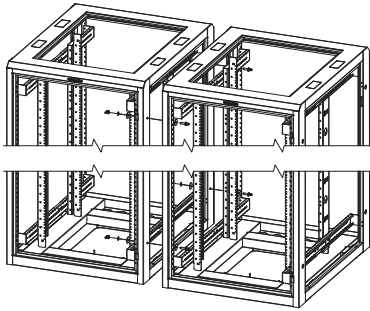

GROUNDING

GROUNDING KIT, GR101

Grounding studs in our E Series cabinets provide a point to which the doors may be grounded to the cabinet and from which the cabinet may be connected to the facility's common ground. The studs are made from copper which is a conducting metal. E Cabinets have three ground studs in the frame: two in top and one in the bottom.

This kit allows you to ground the cabinet so that it is ready to be connected to the common building ground. The kit contains one 48" L ground wire assembly and five 24" L ground wire assemblies. Each assembly is made of two smaller wires that are connected (this allows a 'Quick Disconnect' when the wire must be removed).

Using the grounding wires supplied, connect one end to the copper ground stud on the side panels and/or doors and the other end to the copper ground stud on the cabinet frame. Once all wires have been connected to a frame stud, have at least one frame stud connected to the common building ground.

If a ground wire needs to be disconnected (e.g. when the cabinet door needs to be removed but is attached to the cabinet with the ground wire), simply pull apart the ground wires.

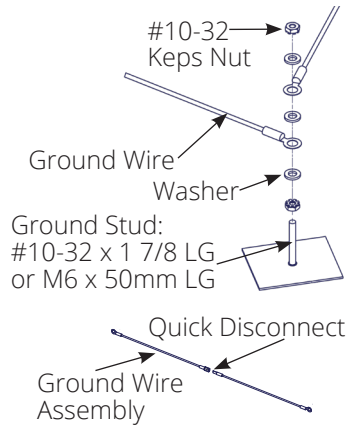

COPPER BUS BARS

It is important to note that grounding the cabinet does not ground the equipment mounted within it. In order for any individual devices and components mounted within an cabinet to be grounded, they must be connected to a copper bus bar. Available copper bus bars include:

- CBB-19 Copper Bus Bar for 19" rack mounting (Isolated)
- CBB-48 Copper Bus Bar for 48"H cabinets (Isolated)
- CBB-60 Copper Bus Bar for 72"H cabinets (Isolated)
- CBB-72 Copper Bus Bar for 84"H cabinets (Isolated)

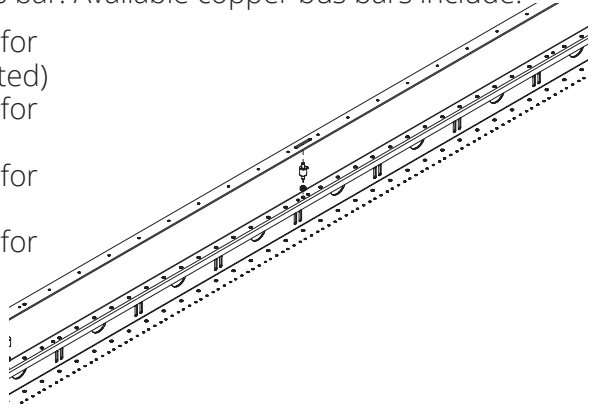

PROTECTIVE GROUNDING

Protective grounding studs are provided along with grounding jumper wires that electrically bond the cabinet doors to the cabinet frame.



WARNING: To avoid injury to persons or loss of life, ground each cabinet individually to the dedicated branch circuit ground.

Connecting Main Protective Grounding Stud to the Dedicated Branch Circuit Ground

Connect the dedicated branch circuit ground connector to the main protective grounding stud located inside at the bottom rear of the cabinet frame using a listed ring or closed-loop terminal.

Connecting Main Protective Grounding Stud to the Protective Bonding Conductors

Connect the rear doors to the main protective grounding studs located inside at the bottom and top rear of the cabinet chassis using a listed ring or closed-loop terminal. Connect the front door to the grounding stud located inside at the bottom front of the cabinet frame using a listed ring or closed-loop terminal.

Parts Not Bonded to Protective Earthing Terminal

The following parts are not effectively bonded to the protective earthing terminal: rails and front to back rail horizontals. If these parts need to be bonded to the protective earthing terminal, do so in accordance with Article 250 of the National Electric Code.



GREAT LAKES
DATA RACKS & CABINETS

Thank you
for your
business!



Corporate Sponsor

ETSI Associate Member

FORM: #MS - 5.02-59, REV #1