

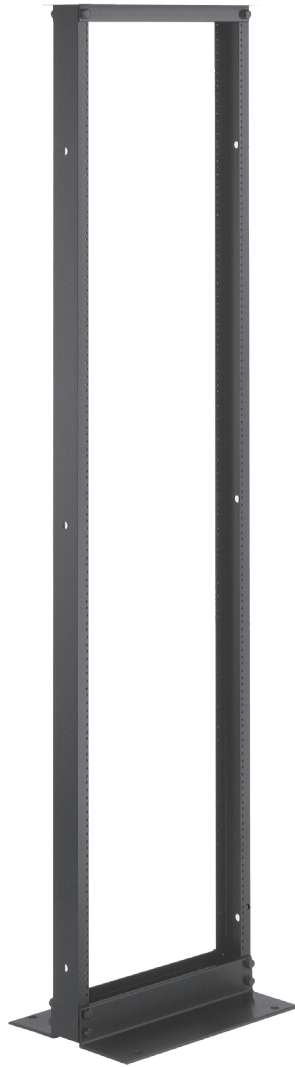

2 POST RACK

Installation Instructions

(UL60950-1/UL2416 GLRR Equipment Rack)



Instructions for the following Great Lakes GLRR Racks:

GLRR-1936, GLRR-1948, GLRR-1960, GLRR-1966, GLRR-1972, GLRR-1984, GLRR-1996, GLRR-19108,
GLRR-2336, GLRR-2348, GLRR-2360, GLRR-2366, GLRR-2372, GLRR-2384, GLRR-2396, GLRR-23108

GreatCabinets.com

1.866.879.4522

PREFACE

This manual is provided to prevent service personnel from committing an act that results in the risk of fire, electric shock, or injury to persons. Only trained service personnel should receive, unpack, and assemble the GLRR Racks (UL60950 -1/UL2416 GLRR Series Equipment Rack). In addition, only trained service personnel should install equipment in the racks.

SAFETY SYMBOLS USED IN THIS MANUAL

This manual provides general safety guidelines to be observed during installation, operation, and maintenance of the GLRR Racks.



WARNING:

Failure to follow directions in the warning could result in injury to persons or loss of life.



WARNING:

Failure to follow directions in the caution could result in damage to equipment or storage data.

SAFTEY CONSIDERATIONS



WARNING: Improper handling and use of the GLRR Racks could result in equipment damage, serious injury, or possible death.

Only trained service personnel should be used to assemble the rack. Also, be sure you have a sufficient number of service personnel. Do not attempt to move the rack by yourself.

Only UL® Listed ITE (Information Technology Equipment) units should be installed inside the GLRR Racks.

Be sure to read and follow all individual manufacturer equipment manuals for safety and installation instructions.

Proper spacing is required when installing electrical equipment to avoid electrical shock. Maintain minimum spacing between the accessories and components and the computer rack assembly for safe operation of the equipment when installed in accordance with the National Electric Code ANSI/NFPA 70-1999.

The ambient temperature operating range for the equipment mounted within GLRR Racks and related accessories is +50 to +95° F (+10 to +35° C).

The non-operating temperature is -4 to +140° F (-20 to +60° C).

INSTALLATION QUESTIONS?

Call Technical Support at 1-866-879-4522 or email TechSupport@GreatCabinets.com

SERVICE

GLRR Racks should be repaired by personnel trained by Great Lakes, or returned to Great Lakes for repair or replacement. Contact Technical Support at 1.866.879.4522 or email TechSupport@GreatCabinets.com

This user's manual applies to the following Great Lakes racks:

PART NO.	FINISH	H	W	RMU
GLRR-1936	Mill Finish	36"	20.31"	17
GLRR-1936BA	Black Anodized	36"	20.31"	17
GLRR-1948	Mill Finish	48"	20.31"	24
GLRR-1948BA	Black Anodized	48"	20.31"	24
GLRR-1960	Mill Finish	60"	20.31"	31
GLRR-1960BA	Black Anodized	60"	20.31"	31
GLRR-1966	Mill Finish	66"	20.31"	35
GLRR-1966BA	Black Anodized	66"	20.31"	35
GLRR-1972	Mill Finish	72"	20.31"	38
GLRR-1972BA	Black Anodized	72"	20.31"	38
GLRR-1984	Mill Finish	84"	20.31"	45
GLRR-1984BA	Black Anodized	84"	20.31"	45
GLRR-1996	Mill Finish	96"	20.31"	52
GLRR-1996BA	Black Anodized	96"	20.31"	52
GLRR-19108	Mill Finish	108"	20.31"	59
GLRR-19108BA	Black Anodized	108"	20.31"	59
GLRR-2336	Mill Finish	36"	24.31"	17
GLRR-2336BA	Black Anodized	36"	24.31"	17
GLRR-2348	Mill Finish	48"	24.31"	24
GLRR-2348BA	Black Anodized	48"	24.31"	24
GLRR-2360	Mill Finish	60"	24.31"	31
GLRR-2360BA	Black Anodized	60"	24.31"	31
GLRR-2366	Mill Finish	66"	24.31"	35
GLRR-2366BA	Black Anodized	66"	24.31"	35
GLRR-2372	Mill Finish	72"	24.31"	38
GLRR-2372BA	Black Anodized	72"	24.31"	38
GLRR-2384	Mill Finish	84"	24.31"	45
GLRR-2384BA	Black Anodized	84"	24.31"	45
GLRR-2396	Mill Finish	96"	24.31"	52
GLRR-2396BA	Black Anodized	96"	24.31"	52
GLRR-23108	Mill Finish	108"	24.31"	59
GLRR-23108BA	Black Anodized	108"	24.31"	59

SPECIFICATIONS

Certifications: UL 60950-1 and UL 2416

Rack Space: Varies by product Size

Construction: Aluminum

Finish: Plain Mill Finish or Black Anodized

Grounding: Grounding lug supplied

Rail Type: Tapped # 12-24 mounting holes, front and rear

Weight Capacity: 1500 lbs. for all sizes

INSTALLATION

Receiving, Unpacking, and Removing the GLRR Rack

Inspect and report any damage before receiving. Unpack the rack by carefully removing the corrugated carton and corners. Avoid damaging the rack when removing packaging.



WARNING: Only trained service personnel should be used to remove the rack from boxes. Also, be sure you have a sufficient number of service personnel. Do not attempt to move rack by yourself.



WARNING: Be careful when moving rack before installation. Sudden stops and starts, excessive force, obstructed routes, and uneven floor surfaces may cause the rack to topple over.

LOADING EQUIPMENT



WARNING: Only install equipment after the GLRR Rack has been properly secured to the floor. Do not move the GLRR Rack assembly while loaded.

Rated or maximum load capacity for the GLRR Rack is 1500 pounds when bolted to the floor.

To maintain a uniform distribution of the mechanical load in the GLRR Rack, load the heaviest equipment first, at the bottom of the GLRR Rack and load the lighter units at the top.

FLOOR INSTALLATION

Once the location on the floor has been determined, inspect the floor surface. The floor must be flat and square in the horizontal and vertical plane to ensure the 2 Post Rack is installed correctly.



WARNING: Improper handling and use of the 2 Post Rack could result in equipment damage, serious injury, or possible death.

MASONRY FLOOR SURFACE

For a masonry floor surface, the installer must provide all the appropriate hardware.

POWER

When using PDUs, each PDU should be connected to a committed branch circuit that is rated for the continuous load of all the equipment connected. When not using a PDU, each piece of equipment should be connected to a dedicated branch circuit.

PROTECTIVE EARTHING/GROUNDING

A main protective earthing lug is provided.



WARNING: To avoid injury to persons or loss of life, ground each 2 Post Rack individually to the dedicated branch circuit earthing ground.

CONNECT MAIN PROTECTIVE EARTHING STUD TO THE DEDICATED BRANCH CIRCUIT EARTHING GROUND CONDUCTOR

Locate and attach the main protective earthing lug to the 2 Post Rack and secure set screws. Connect the dedicated branch circuit earthing ground conductor to the main protective lug.

OVERVIEW

2 Post Racks are designed to securely hold 19" or 23" rack mount equipment, networking equipment, phone equipment, etc. in tight spaces or closets.

Your package includes the following items:

COMPONENT	QTY.
VERTICAL UPRIGHT CHANNEL.....	2
BASE ANGLE	2
TOP ANGLE	2
½"- 13 X 1 HEX BOLT	12
½" LOCK WASHER	12
#12-24 X ½"LG. SCREWS	50
2 BARREL GROUND LUG	1

TOOLS REQUIRED: ¾" SOCKET OR WRENCH AND A LEVEL OR CARPENTER SQUARE

ASSEMBLY INSTRUCTIONS

STEP 1

Install top angles to vertical upright channels.

- A. Lay vertical upright channels on edge so tapped holes face you and the floor. Be sure open sides of upright channels face each other.
- B. Align holes in top angle with corresponding holes in vertical uprights. Formed leg of top angle should be facing toward you.
- C. Install 2 hex head bolts and lock washers. Finger tighten only.
- D. Turn vertical upright assembly over (rotate 180 degrees) and repeat steps B and C. **Finger tighten only.**

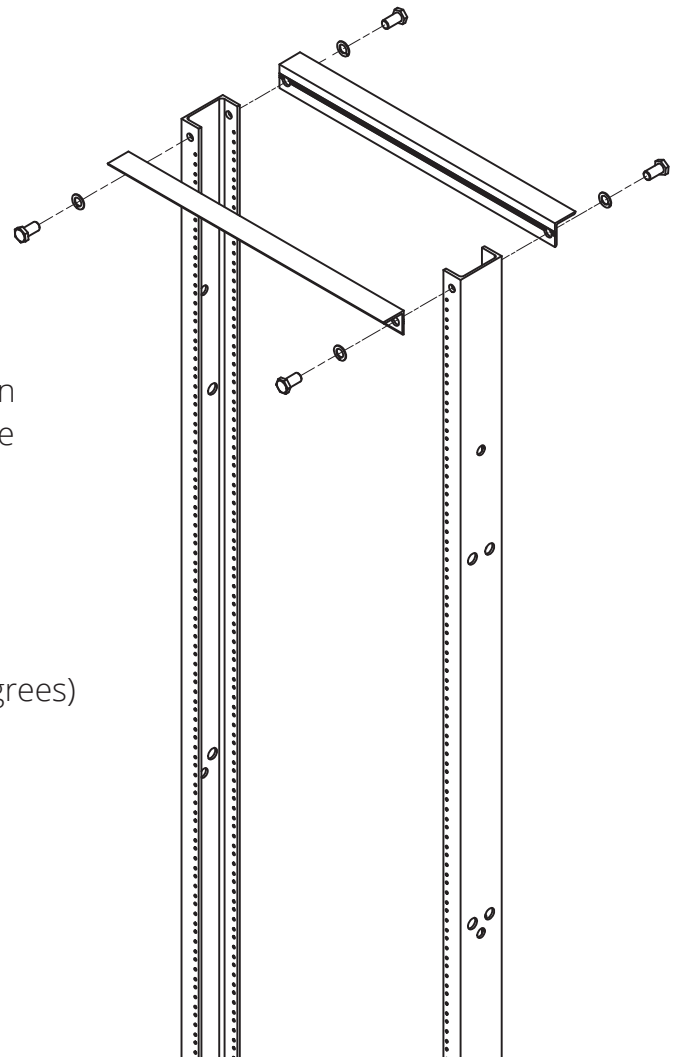

STEP 2

- A. Leaving vertical upright channels on edge, align holes in base with corresponding holes in each upright channel. Long leg of base should be facing you.
- B. Install 4 hex head bolts and lock washers. **Finger tighten only.**
- C. Turn vertical upright assembly over (rotate 180 degrees) and repeat steps A and B. **Finger tighten only.**

STEP 3

- A. Stand rack upright.
- B. Square unit using a level or carpenter square.
- C. Tighten all bolts using socket or wrench. (54 ft-lb torque is recommended).

STEP 4

Secure rack to floor.

All racks should be bolted to a masonry floor, or to an equally stabilizing and secure surface, after desired location is determined. Hardware is not provided for bolting rack to the floor, but Great Lakes' AK101 Seismic Anchor Kit is recommended for masonry floors.

STEP 5

Install main protective earthing lug as shown.

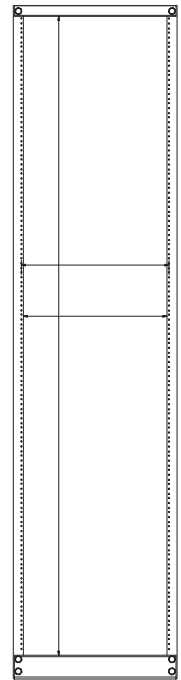
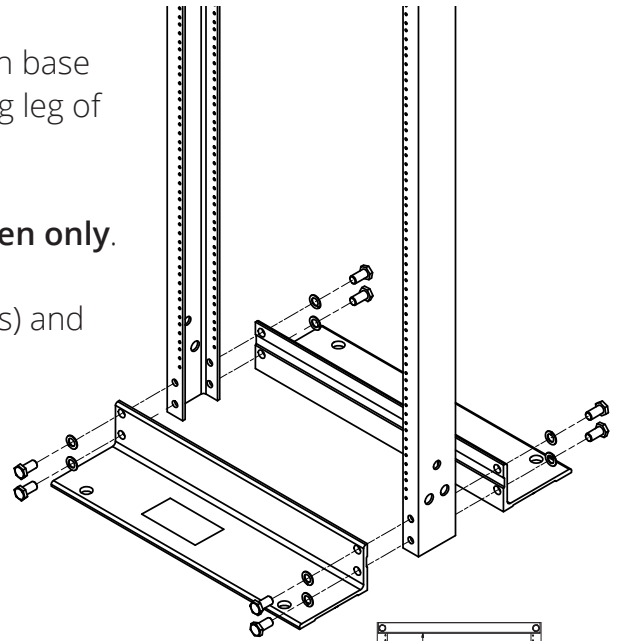
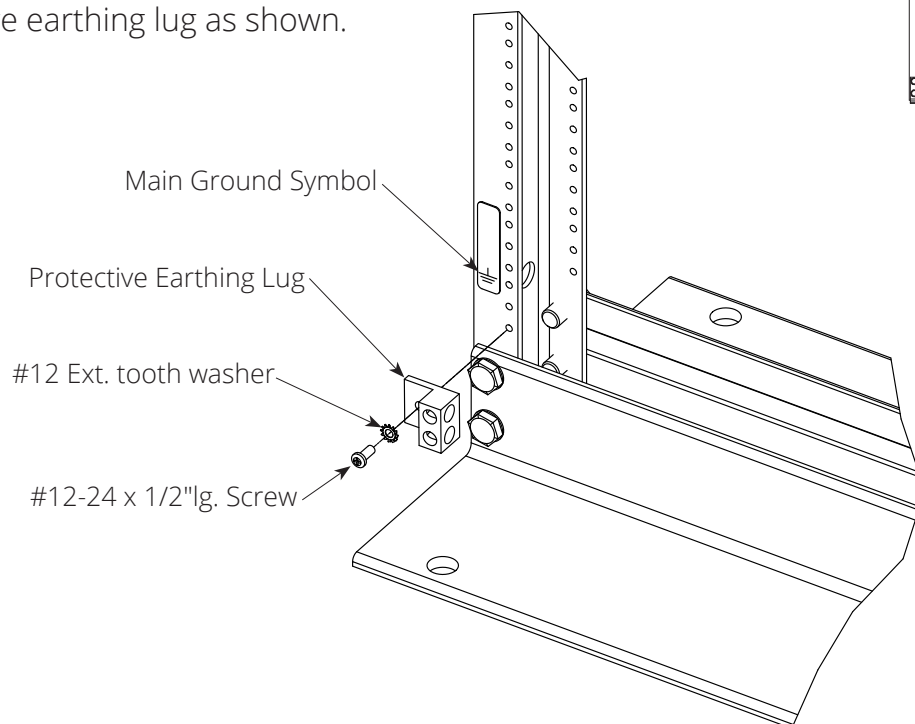



Thank you
for your
business!



ETSI Associate Member

FORM: #MS-5.02-15 Rev. 4