

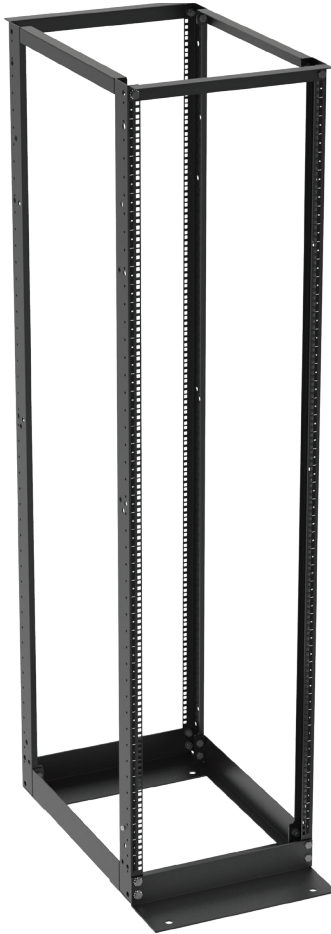

# Four Post Rack Installation Instructions

(UL60950-1/UL2416, 4 Post Equipment Racks)



GreatCabinets.com

1.866.879.4522

## PREFACE

This manual is provided to prevent service personnel from committing an act that results in the risk of fire, electric shock, or injury to persons. Only trained service personnel should receive, unpack, and assemble the racks. In addition, only trained service personnel should install equipment in enclosures.

## SAFETY SYMBOLS USED IN THIS MANUAL

This manual provides general safety guidelines to be observed during installation, operation, and maintenance of the racks.



**WARNING:** Failure to follow directions in the warning could result in injury to persons or loss of life.

## INSTALLATION

### RECEIVING, UNPACKING, AND REMOVING THE RACK

Inspect and report damage before receiving. Unpack the rack by carefully removing the corrugated cartons and corners. Avoid damaging the rack when removing packaging.

## SERVICE

The 4 Post Racks should be repaired by personnel trained by Great Lakes, or returned to Great Lakes for repair or replacement. Contact Great Lakes Technical Support at 814.734.7303 or at [werackyourworld.com](http://werackyourworld.com)



**WARNING:** Improper handling and use of the racks could result in equipment damage, serious injury, or possible death.

## SAFETY CONSIDERATIONS

Only trained service personnel should be used to remove the enclosure from the pallet. Also, be sure you have a sufficient number of service personnel. Do not attempt to move enclosures by yourself.

## LOADING EQUIPMENT



**WARNING:** Only install equipment after the 4 Post Rack has been properly secured. Do not move the rack assembly while loaded. To maintain a uniform distribution of the mechanical load in the rack, load the heaviest equipment first, at the bottom of the rack and load the lighter units at the top.

Only UL® Listed ITE (Information Technology Equipment) units should be installed inside the rack.

Be sure to read and follow all individual manufacturer equipment manuals for safety and installation instructions.

Proper spacing is required when installing electrical equipment to avoid electrical shock. Maintain minimum spacing between the accessories and components and the computer enclosure assembly for safe operation of the equipment when installed in accordance with the National Electric Code ANSI/NFPA 70-1999.

The ambient temperature operating range for the racks and accessories is +50 to +95° F (+10 to +35° C). The non-operating temperature is -4 to +140° F (-20 to +60° C).

## 4PM6 FOUR POST RACK

### OVERVIEW

4PM6 Racks are designed to securely hold 19" rack mount equipment, networking equipment, etc.

Components of the 4 Post Rack will ship in three separate boxes. Boxes will be marked with the box number and an item number.

### What's Included:

Component	Qty.	Component will ship in:
Vertical Uprights (2 left/2 right)	4	Box #1, Item GL4PM6
Rack Mounting Hardware	50	
Top Width Brackets	2	Box #2, Item GL4PBT
Bottom Width Brackets	2	
Rack Assembly Hardware & Grounding Lug	-	
Top Depth Brackets	2	Box #3, Item GL4PFB24XX (XX=24, 29, 32 or 36)
Bottom Depth Brackets	2	

# SPECIFICATIONS

Part No.	RMU	H"	W"	Channel Depth"	Overall Depth"	Rail Rating lbs
4P-45U24M6	45	84	20	24	36	1500
4P-45U29M6	45	84	20	29	41	1500
4P-45U32M6	45	84	20	32	44	1500
4P-45U36M6	45	84	20	36	48	1500
4P-45U42M6*	45	84	20	42	54	1500

**Certifications:** UL Listed 2416 (parts marked with \* are not UL Listed)

**Construction:** Vertical Uprights, Top and Bottom Depth Brackets, Top and Bottom Width Brackets: 12 ga. steel

**Finish:** Steel - Black Powder Coat

**Grounding:** Ground lug installed on Vertical Uprights

**Rail Type:** 3/8" sq. (M6) Cage Nuts

**Total Max. Load Capacity:** 1500 lbs.

## 4PM6 ASSEMBLY INSTRUCTIONS

Tools Required: 3/4" x 7/16" sockets and 3/4" wrench

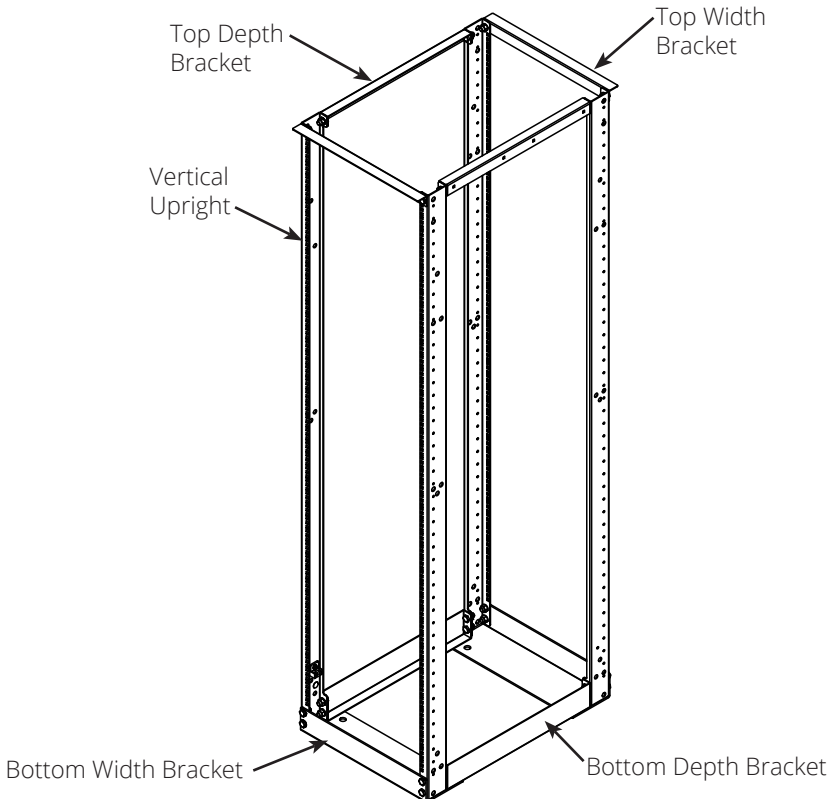

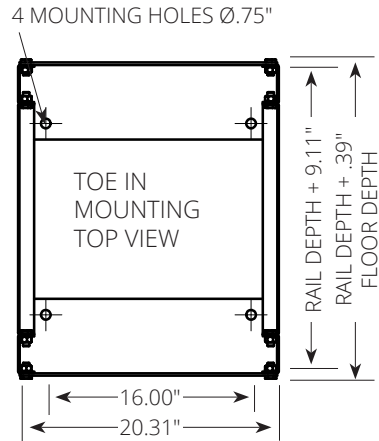
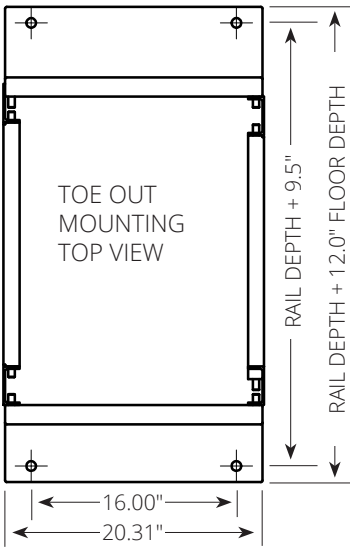

## ASSEMBLY

1. Assemble top and bottom width brackets to uprights (place the bracket with the Great Lakes label on the top). Do not tighten. Bottom width brackets can be assembled with toe out or toe in mounting.
2. Assemble the top and bottom depth brackets to the uprights and stand assembly up, Make sure rack is square and then tighten all hardware. (54 ft-lb torque is recommended).
3. Secure rack to floor. All racks should be bolted to a masonry floor, or to an equally stabilizing and secure surface, after desired location is determined. Hardware is not provided for bolting rack to the floor, Great Lakes' AK101 Seismic Anchor Kit is recommended for masonry floors.
4. Locate the hole near the IEC 60417 earthing symbol on the upright and attach the main protective earthing lug. Note: The same hardware pack for grounding is supplied with 4PM6 and 4P1224 racks. #12-24 screw and #12 Ext. Tooth Washer will not be used when installing the protective earthing lug on the 4PM6.

# TOP BRACKET

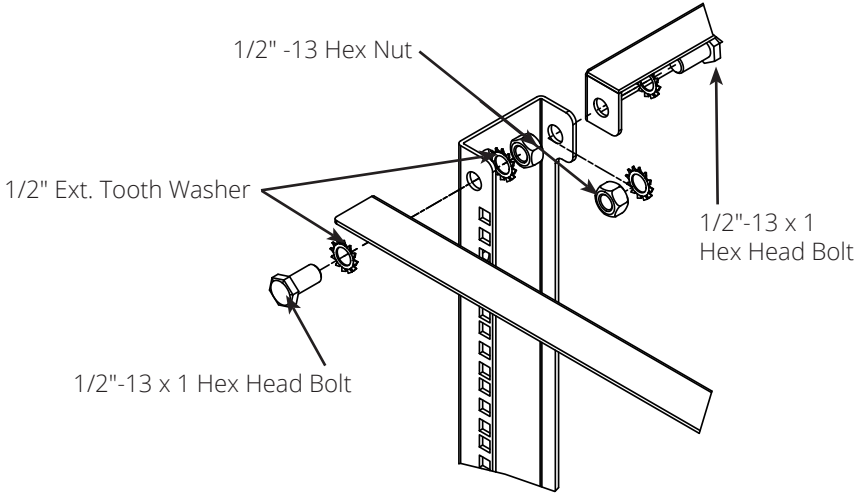

# BOTTOM BRACKET - TOE IN MOUNTING

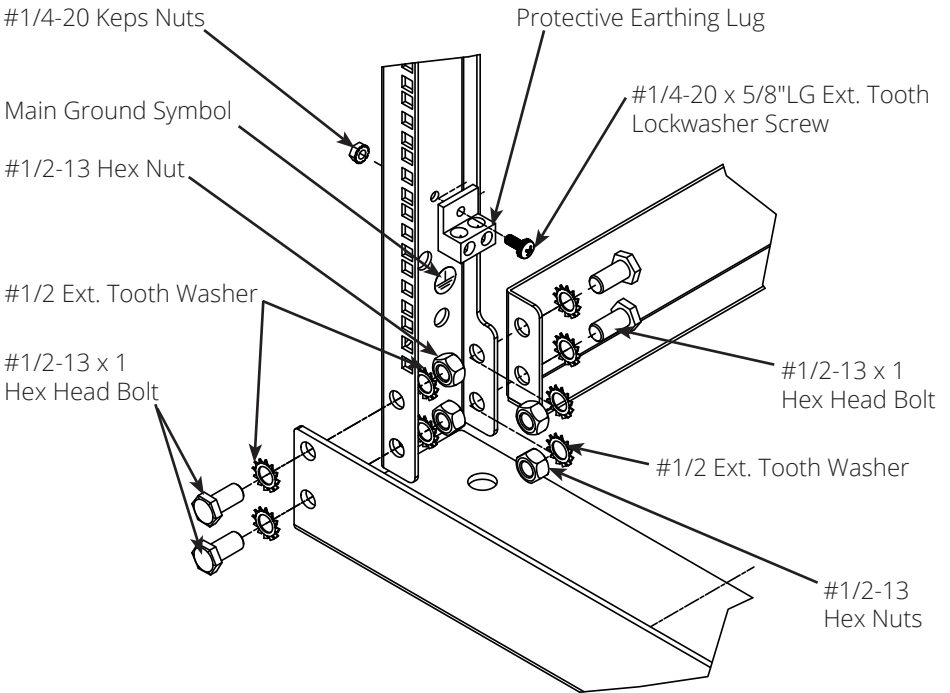

# 4P1224 FOUR POST RACK

## OVERVIEW

4P1224 Racks are designed to securely hold 19" rack mount equipment, networking equipment, etc.

Components of the 4 Post Rack will ship in three separate boxes. Boxes will be marked with the box number and an item number.

### What's Included:

Component	Qty.	Component will ship in:
Vertical Uprights (2 left/2 right)	4	Box #1, Item GL4P1224V
Rack Mounting Hardware	50	
Top Width Brackets	2	Box #2, Item GL4PBT
Bottom Width Brackets	2	
Rack Assembly Hardware & Grounding Lug	-	
Top Depth Brackets	2	Box #3, Item GL4PFB24XX (XX=24, 29, 32 or 36)
Bottom Depth Brackets	2	

# SPECIFICATIONS

Part No.	RMU	H"	W"	Channel Depth"	Overall Depth"	Rail Rating lbs.
4P-45U24	45	84	20	24	36	1500
4P-45U29	45	84	20	29	41	1500
4P-45U32	45	84	20	32	44	1500
4P-45U36	45	84	20	36	48	1500
4P-45U42*	45	84	20	42	54	1500
4P-52U24	52	96.25	20	24	36	1500
4P-52U29	52	96.25	20	29	41	1500
4P-52U32	52	96.25	20	32	44	1500
4P-52U36	52	96.25	20	36	48	1500
4P-52U42*	52	96.25	20	42	54	1500
4P-59U24	59	108.5	20	24	36	1500
4P-59U29	59	108.5	20	29	41	1500
4P-59U32	59	108.5	20	32	44	1500
4P-59U36	59	108.5	20	36	48	1500
4P-59U42*	59	108.5	20	42	54	1500

Certifications: UL Listed 2416 (parts marked with \* are not UL Listed)

Construction: Vertical Uprights, extruded aluminum; Top and Bottom Depth Brackets and Top and Bottom Width Brackets, 12 ga.steel

Finish: Black Powder Coat

Grounding: Ground lug installed on Vertical Uprights

Rail Type: 1#12-24 tapped

Total Max. Load Capacity: 1500 lbs.



# 4P1224 ASSEMBLY INSTRUCTIONS

Tools Required: 3/4" x 7/16" sockets and 3/4" wrench

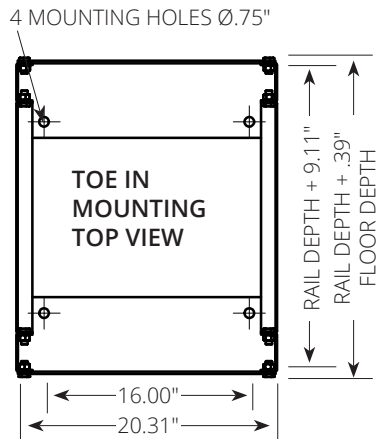
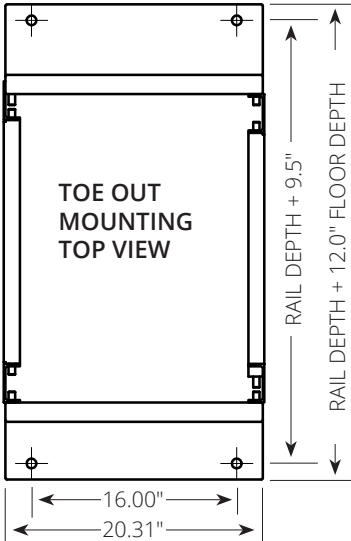
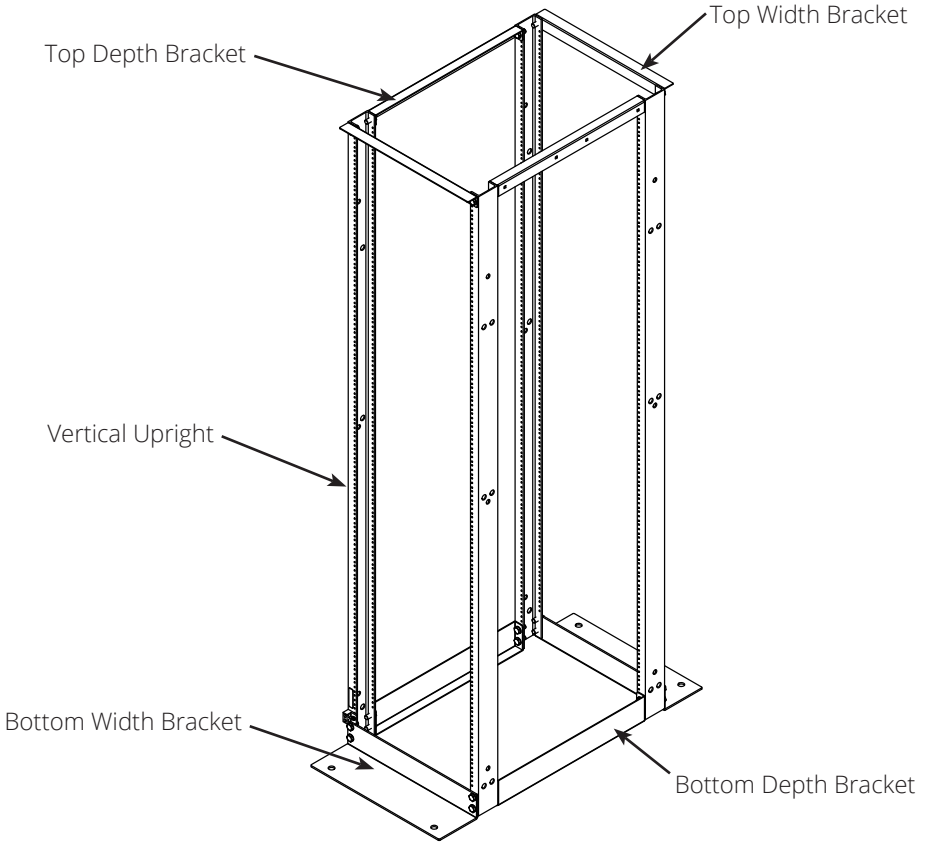

## ASSEMBLY

1. Assemble top and bottom width brackets to uprights (place the bracket with the Great Lakes label on the top). Do not tighten. Bottom width brackets can be assembled with in toe out or toe in mounting.

2. Assemble the top and bottom depth brackets to the uprights and stand assembly up. Make sure rack is square and then tighten all hardware (54 ft-lb torque is recommended).

3. Secure rack to floor. All racks should be bolted to a masonry floor, or to an equally stabilizing and secure surface, after desired location is determined. Hardware is not provided for bolting rack to the floor, but Great Lakes' AK101 Seismic Anchor Kit is recommended for masonry floors.

4. Install main protective earthing lug with #12-24 x 1/2" screw at main ground symbol located at the base of the upright on the #12-24 tapped hole.

### TOP BRACKET

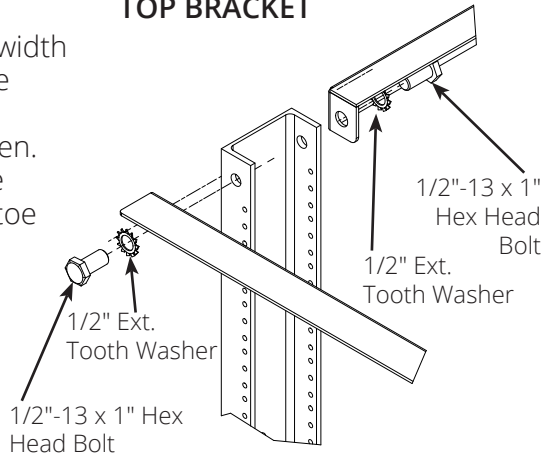

### BOTTOM BRACKET - TOE OUT MOUNTING

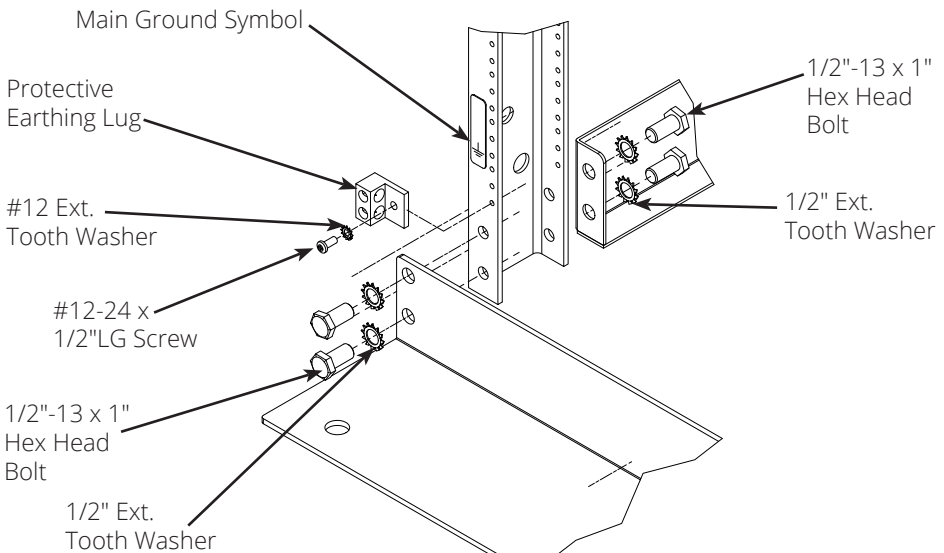

## **POWER AND GROUNDING OF ALL RACKS**

When using PDUs, each PDU should be connected to a committed branch circuit that is rated for the continuous load of all the equipment connected. When not using a PDU, each piece of equipment should be connected to a dedicated branch circuit.

### **PROTECTIVE EARTHING/GROUNDING**

A main protective earthing lug is provided.



**WARNING:** To avoid injury to persons or loss of life, ground rack individually to the dedicated branch circuit earthing ground.

### **CONNECTING MAIN PROTECTIVE EARTHING LUG TO THE DEDICATED BRANCH CIRCUIT EARTHING GROUND CONDUCTOR**

Connect the dedicated branch circuit earthing ground conductor to the main protective earthing stud located on the support frame using a listed ring or closed-loop terminal.

Although equipment may physically fit into a Great Lakes rack, with or without brackets, customers must also review and comply with the equipment manufacturer's installation and other requirements. For more information, please contact your Great Lakes representative or call 1.866.879.4522

When any equipment or accessory is installed in a Great Lakes product, the installation procedures, recommendations and product warranty requirements of the equipment manufacturer must be followed. Great Lakes will not be responsible for any losses or claims arising from a customer's installation of electrical, electronic or other third party products in any Great Lakes racks, unless caused solely by a written configuration prepared by Great Lakes for that customer or by a configuration provided by Great Lakes' website, any configuration relies on complete and accurate information from the customer.

Product specifications are subject to change without prior notice.



Thank you  
for your  
business!



ETSI Associate Member

FORM: #MS - 5.02-45, REV 1