



GREAT LAKES

DATA RACKS & CABINETS

L Series Cabinets Installation Instructions

(UL2416, CSA C22.2 No. 60950-1

L Series Equipment Cabinet/Rack)

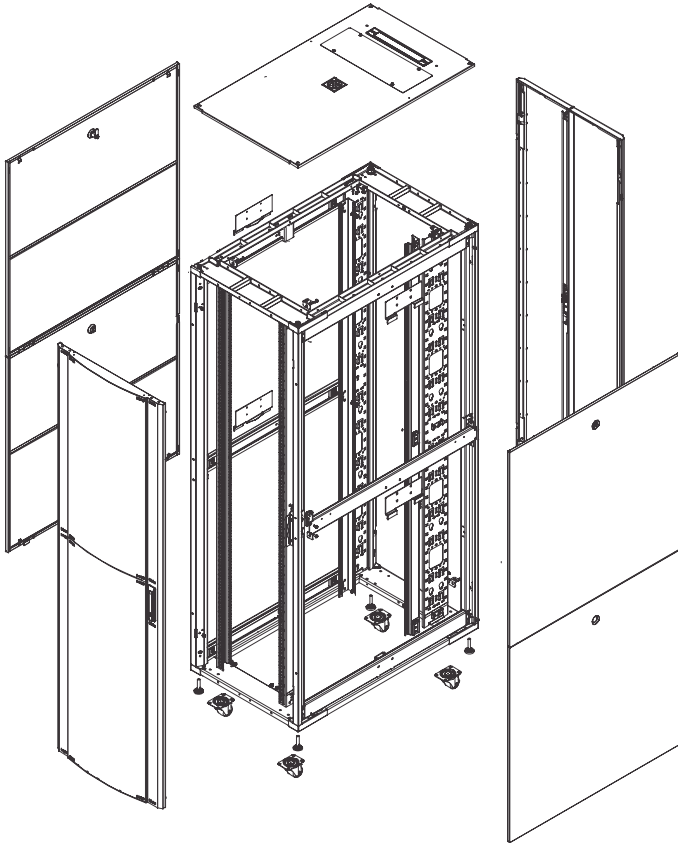

Instructions for the following
Great Lakes Cabinets:

GL910L-3248, GL910L-3242, GL910L-2448, GL910L-2442,
GL790L-3248, GL790L-3242, GL790L-2448, GL790L-2442

GreatCabinets.com

1.866.879.4522

PREFACE

This manual is provided to prevent service personnel from committing an act that results in the risk of fire, electric shock, or injury to persons. The equipment shall be installed or serviced by trained service personnel in accordance with the applicable requirements of the National Electrical Code, ANSI/NFPA 70 or Canadian Electrical Code and the applicable sections of ANSI C2, the National Electrical Safety Code. Not following these instructions could result in the risk of fire, electric shock, or injury to persons.

SAFETY SYMBOLS USED IN THIS MANUAL

This manual provides general safety guidelines to be observed during installation, operation, and maintenance of the L Cabinet.



WARNING: Failure to follow directions in the warning could result in injury to persons or loss of life.



CAUTION: Failure to follow directions in the caution could result in damage to equipment or storage data.

SAFETY CONSIDERATIONS



WARNING: Improper handling and use of the L Cabinet could result in equipment damage, serious injury, or possible death.

When applicable, rack systems are not intended as enclosures and do not provide any degree of protection as that of a cabinet.

Only trained service personnel should be used to remove the enclosure from the pallet. Also, be sure you have a sufficient number of service personnel. Do not attempt to move enclosures by yourself.

Only UL® Listed ITE (Information Technology Equipment) units should be installed inside the L Cabinet.

Be sure to read and follow all individual manufacturer equipment manuals for safety and installation instructions.

Proper spacing is required when installing electrical equipment to avoid electrical shock. Maintain minimum spacing between the accessories and components and the computer enclosure assembly for safe operation of the equipment when installed in accordance with

the National Electric Code ANSI/NFPA 70-1999. Only identical L Cabinets should be installed together when ganging. The ambient temperature operating range for the L Cabinet and accessories is +50 to +95° F (+10 to +35° C). The non-operating temperature is -4 to +140° F (-20 to +60° C).

SERVICE

L Cabinets should be repaired by personnel trained by Great Lakes, or returned to Great Lakes for repair or replacement. Contact Great Lakes Technical Support at 814.734.7303 or at GreatCabinets.com

WHAT'S INCLUDED

- L unit (assembled)
- Keys as needed (depending on configuration)
- (50) M6 cage nuts (3/8" square) and M6 screws
- This user's manual

Part No.	RMU	W	D
GL790L-2442MSS	42	23.62" (600mm)	39.37" (1000mm)
GL790L-2448MSS	42	23.62" (600mm)	47.24" (1200mm)
GL790L-3242MSS	42	31.50" (800mm)	39.37" (1000mm)
GL790L-3248MSS	42	31.50" (800mm)	47.24" (1200mm)
GL910L-2442MSS	47	23.62" (600mm)	39.37" (1000mm)
GL910L-2448MSS	47	23.62" (600mm)	47.24" (1200mm)
GL910L-3242MSS	47	31.50" (800mm)	39.37" (1000mm)
GL910L-3248MSS	47	31.50" (800mm)	47.24" (1200mm)

Note: prior to 2020, "L cabinets" were labeled as "LA cabinets". Physical product is identical and documentation only differs by listed part number:

New Part No.	Old Part No.
GL790L-2442MSS	GL790LA-2442MSS
GL790L-2448MSS	GL790LA-2448MSS
GL790L-3242MSS	GL790LA-3242MSS
GL790L-3248MSS	GL790LA-3248MSS
GL910L-2442MSS	GL910LA-2442MSS
GL910L-2448MSS	GL910LA-2448MSS
GL910L-3242MSS	GL910LA-3242MSS
GL910L-3248MSS	GL910LA-3248MSS

INSTALLATION

Receiving, Unpacking, and Removing the L Cabinet from the Pallet

Inspect and report any damage before receiving. Unpack the enclosure by carefully removing the corrugated carton and corners. Avoid damaging the enclosure when removing packaging.



WARNING: Only trained service personnel should be used to remove the enclosure from the pallet. Also, be sure you have a sufficient number of service personnel. Do not attempt to move enclosures by yourself.



WARNING: Be careful when moving enclosures before installation. Sudden stops and starts, excessive force, obstructed routes, and uneven floor surfaces may cause the enclosure to topple over.

Loading Equipment



WARNING: Only install equipment after the L Cabinet has been properly secured. Do not move the L Cabinet assembly while loaded.

Once in place at the desired/intended location, deploy the leveling feet for maximum stability.

If stabilizing brackets are used, they must be tightened until they are flush to the frame.

Rated or maximum load capacity for the L Cabinet is 3080 lbs. on the floor or on leveling glides.

No EIA slide rail location instructions are provided here, location is determined by end user.

To maintain a uniform distribution of the mechanical load in the L Cabinet, load the heaviest equipment first, at the bottom of the L Cabinet and load the lighter units at the top.

OVERALL DIMENSIONS - ASSEMBLED L CABINET

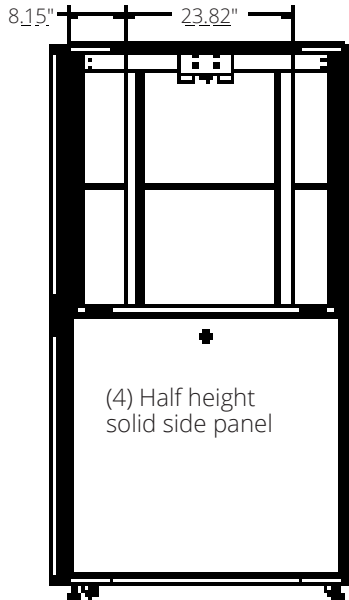
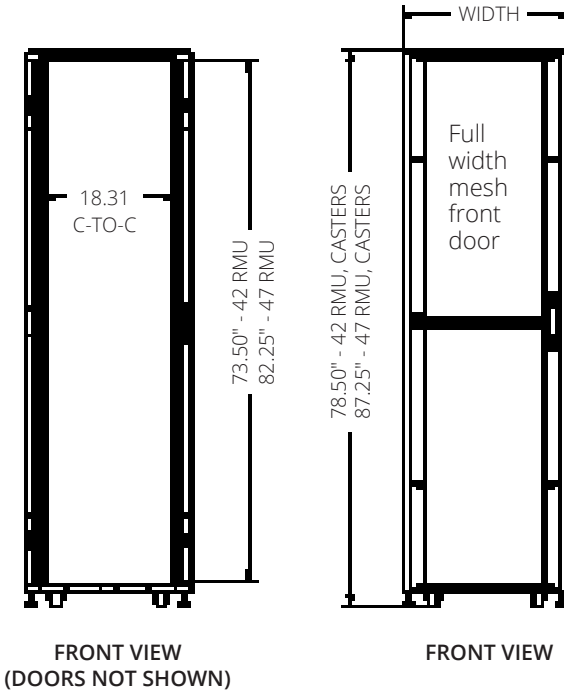

OVERALL DIMENSIONS - ASSEMBLED L CABINET (CONTINUED)

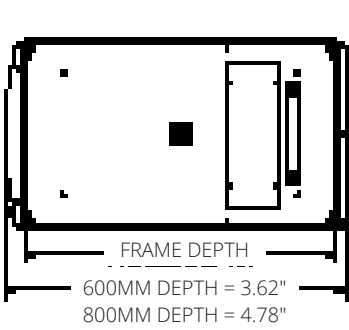

SIDE VIEW

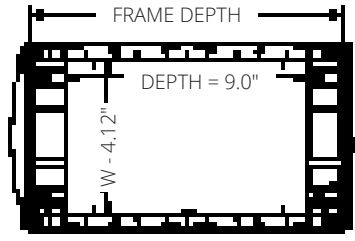

BOTTOM VIEW

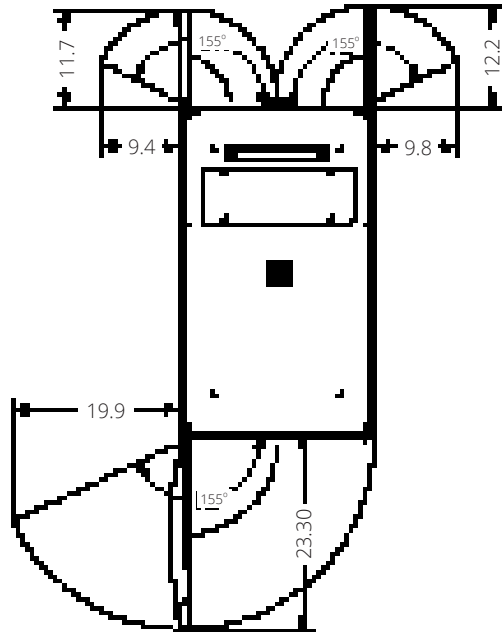

TOP VIEW

TOP PANEL ASSEMBLY

STEP 1

Install top panel fixing bracket. 4 pieces to top frame. See detail A1 and A2. Install top panel to frame top. See detail A3

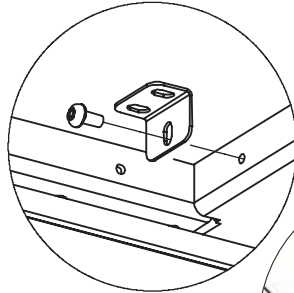
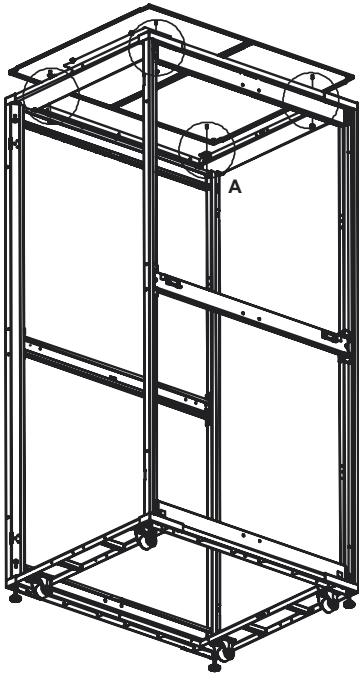

DETAIL A1

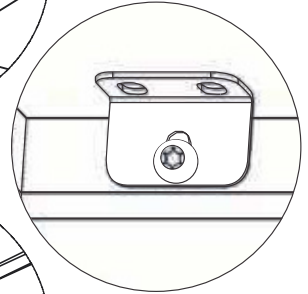

DETAIL A2

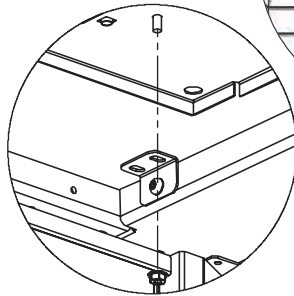

DETAIL A3

Note: 2 holes attach to top panel. 1 hole attaches to top frame.

ATTACH BOTTOM SIDE PANEL

STEP 2

Side panels are common parts, install bottom side panel.

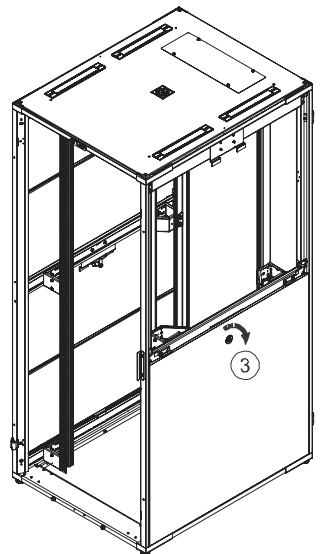
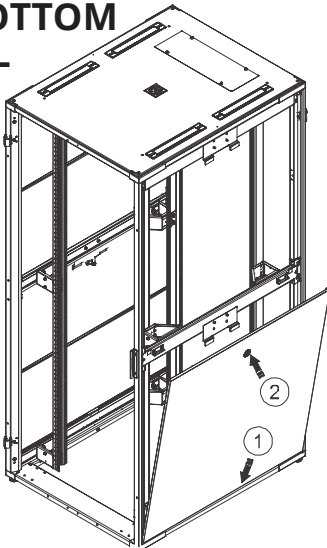

ATTACH TOP SIDE PANEL

STEP 3

Install top side panel.

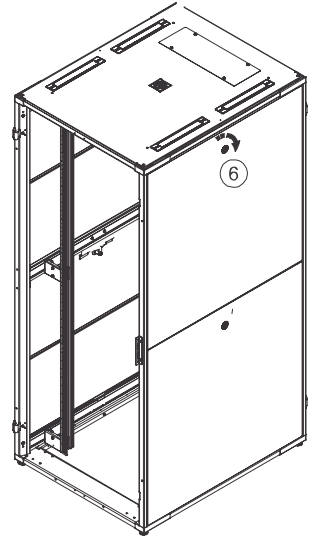
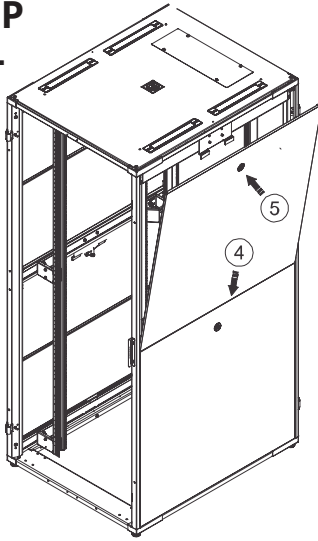

FRONT DOOR ASSEMBLY

STEP 4

Install front door hinges 2 pieces (see detail B). Install door latch bracket to front vertical frame (see detail C).

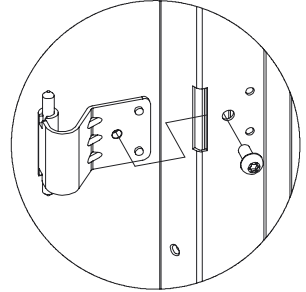
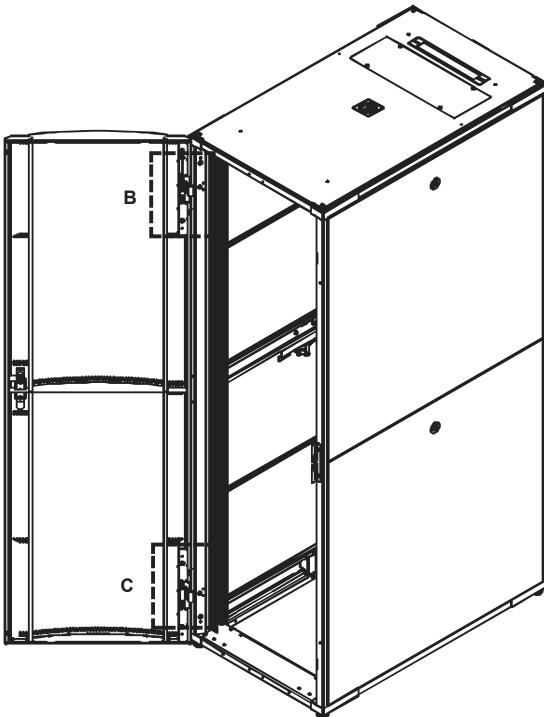

DETAIL B

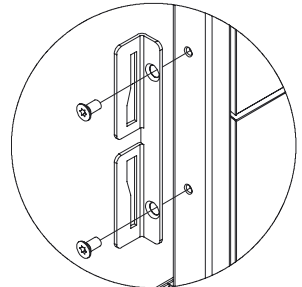

DETAIL C

INSERT HINGE BUSHINGS

STEP 5

Insert hinge bushings on both door hinges. Assemble door onto door hinges (see detail D and E). Attach ground wire after door is installed (see detail D).

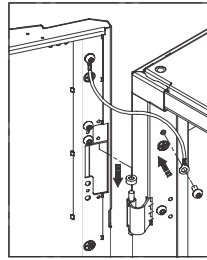
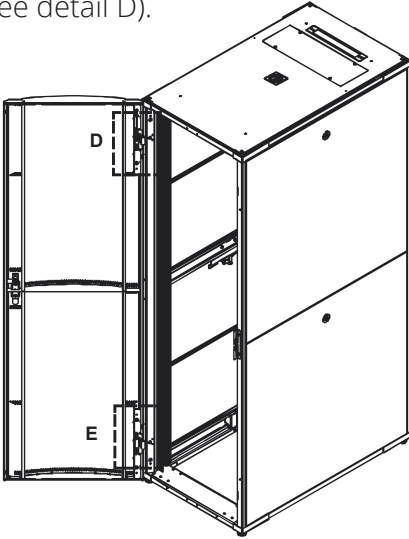

DETAIL D

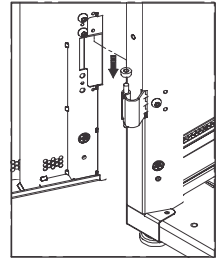

DETAIL E

HARDWARE

- Torx Head Screw M6 x 12 - Qty. 3
- Screw Torx Taper M6 x 12 - Qty. 2
- Hinge Bush - Qty. 2
- Set torque 50-55in.lbs

REAR DOOR ASSEMBLY

STEP 6

Install rear door hinges 4 pieces (see detail F). Install door latch brackets to back vertical post (see detail G).

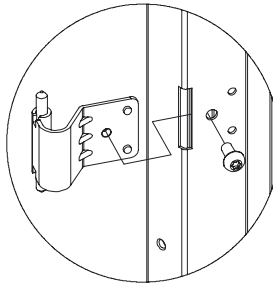
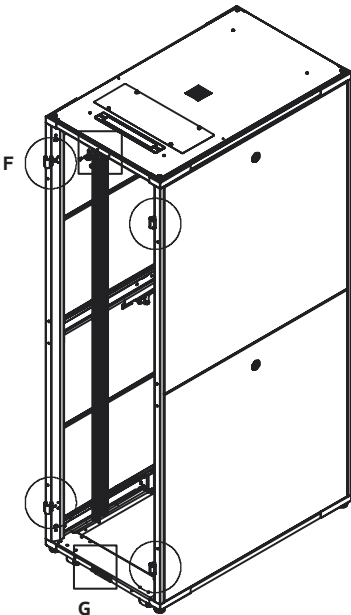

DETAIL F

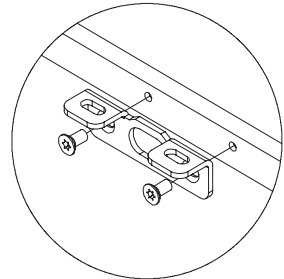

DETAIL G

PDU/VERTICAL CABLE MANAGEMENT RAIL

STEP 7

1. PDU/Vertical Cable Rail normally installs at the rear of cabinet. One rail is included as standard with the cabinet. Drawing shows two to demonstrate rail can be installed in either corner.
2. Install Vertical Cable Rail with Post Mounting Bracket and Middle Side Brace at the rear of cabinet. See steps 1 and 2 in Detail H below.

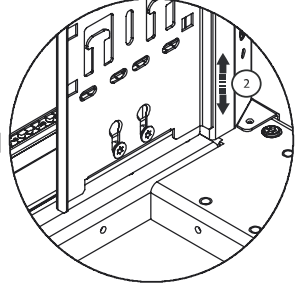
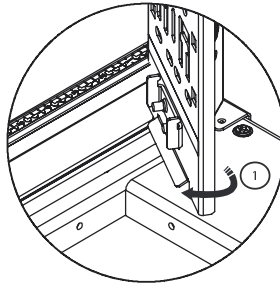
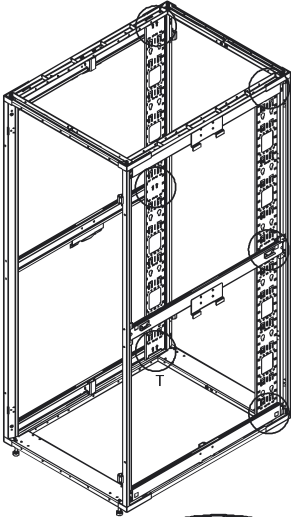

DETAIL H

3. Lift up screws to lock the position and set torque at 50-60 lbs. See step 3 in Detail I below.

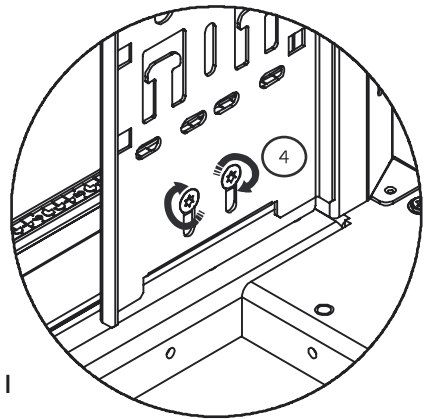
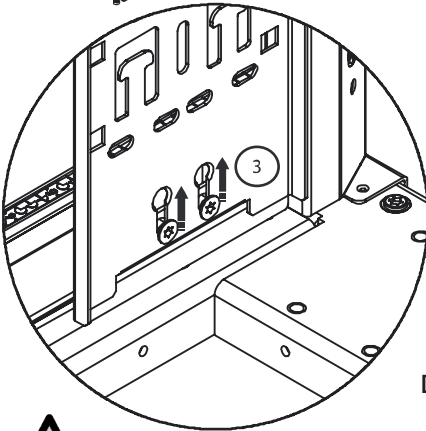

DETAIL I



POWER

When using power distribution units (PDUs), each PDU should be connected to a committed branch circuit that is rated for the continuous load of all the equipment connected. When not using a PDU, each piece of equipment should be connected to a dedicated branch circuit.

GROUNDING

Protective grounding locations are provided along with grounding jumper wires that electrically bond the enclosure doors and sides to the enclosure frame. Before removing doors and side panels, remove the grounding wires.

COPPER BUS BARS

It is important to note that grounding the enclosure does not ground the equipment mounted within it. In order for any individual devices and components mounted within an enclosure to be grounded, they must be connected to a copper bus bar. The CBB-19 Copper Bus Bar for 19" rack mounting (Isolated) can be used in all LA enclosures.

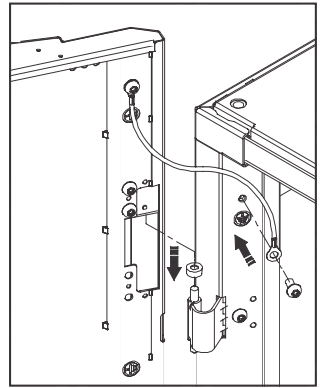

PROTECTIVE GROUNDING

Protective grounding studs are provided along with grounding jumper wires that electrically bond the enclosure doors, sides, and top to the enclosure frame.



WARNING: To avoid injury to persons or loss of life, ground each enclosure individually to the dedicated branch circuit ground.

Connecting Main Protective Grounding Stud to the Dedicated Branch Circuit Ground

Connect the dedicated branch circuit ground connector to the main protective grounding stud located inside at the bottom rear of the enclosure frame using a listed ring or closed-loop terminal.

Connecting Main Protective Grounding Stud to the Protective Bonding Conductors

Connect the rear doors to the main protective grounding studs located inside at the bottom and top rear of the enclosure chassis using a listed ring or closed-loop terminal. Connect the front door to the grounding stud located inside at the bottom front of the enclosure frame using a listed ring or closed-loop terminal.

Parts Not Bonded to Protective Earthing Terminal

The following parts are not effectively bonded to the protective earthing terminal: rails and front to back rail horizontals and PDU brackets. If these parts need to be bonded to the protective earthing terminal, do so in accordance with Article 250 of the National Electric Code.



GREAT LAKES

DATA RACKS & CABINETS

Thank you for your business!



ETSI Associate Member

FORM: #MS - 5.02-60, REV 10