

REAR EXPLODED VIEW

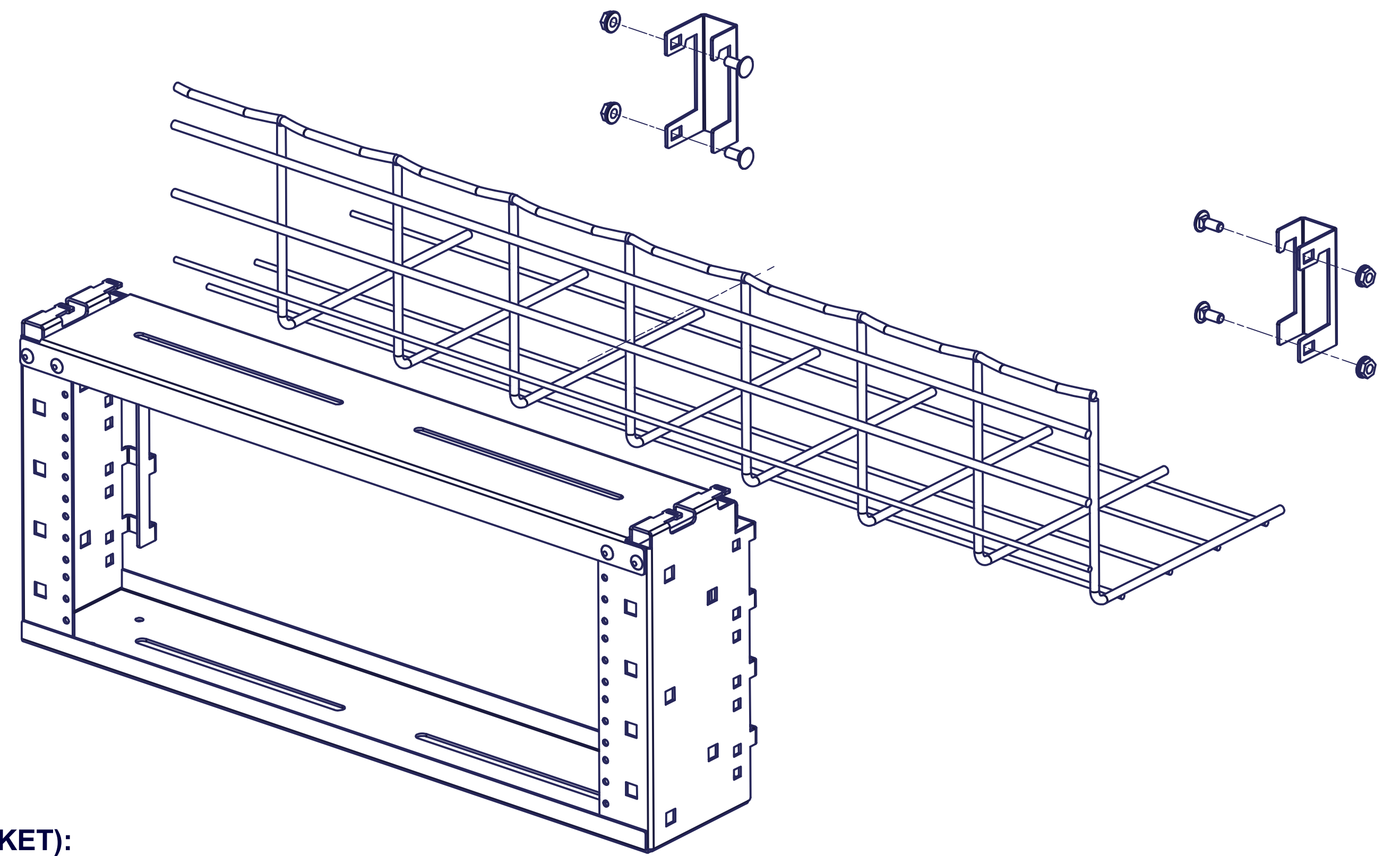

FRONT EXPLODED VIEW

HANGING RACK INSTALLATION STEPS (ON SIDE OF WIRE BASKET):

1. IDENTIFY MOUNTING BRACKETS TO HOLD HANGING RACK.
2. USE 1/4-20 CARRIAGE BOLTS AND 1/4-20 FLANGED LOCK NUT TO ATTACH SYSTEM.
3. ALIGN HANGING RACK TO WIRE BASKET IN DESIRED MOUNTING POSITION.
4. HOLD IN PLACE WITH MOUNTING BRACKETS AND 1/4-20 BOLTS AND NUTS AS SHOWN.

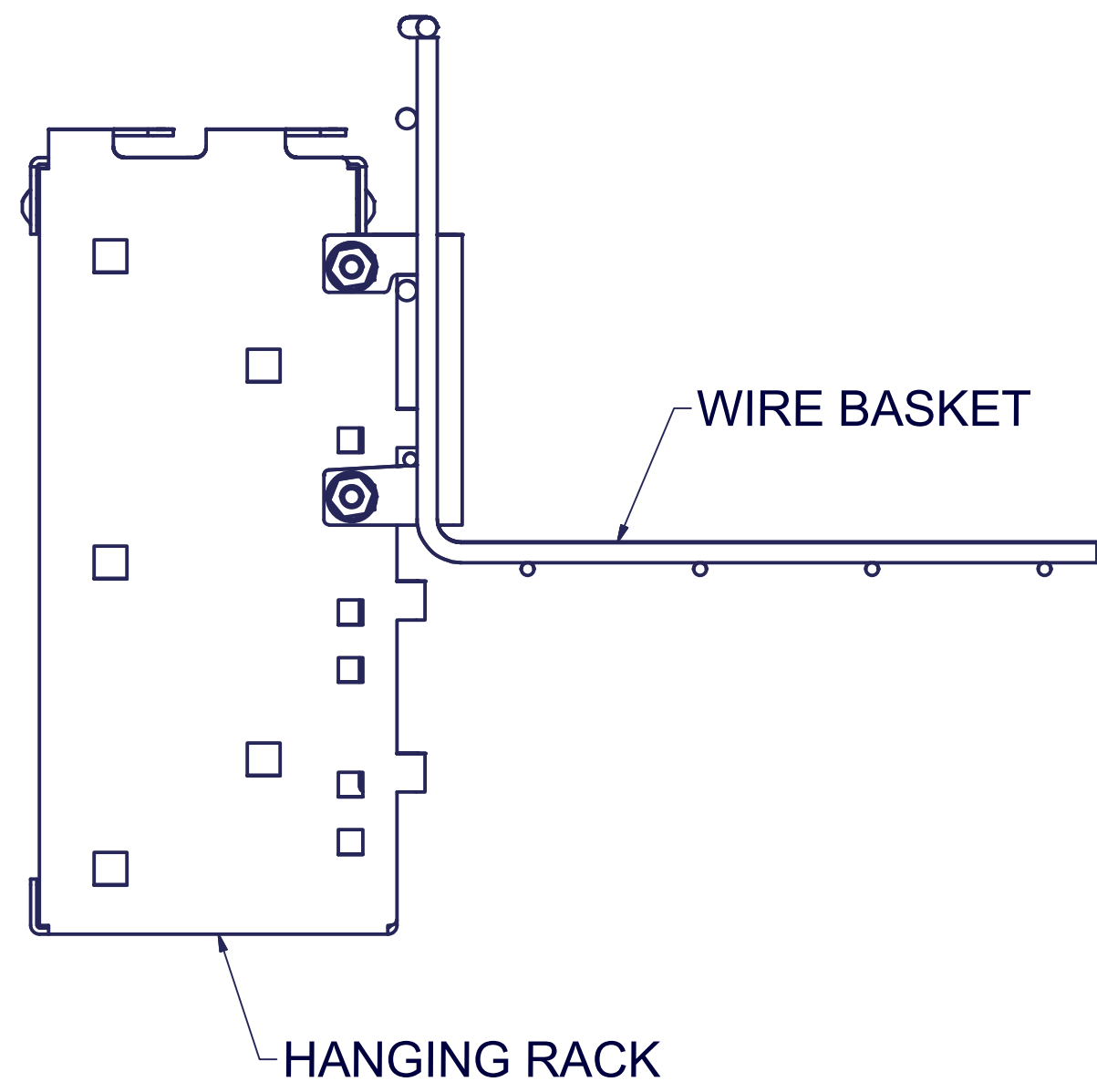

BELOW MOUNTING

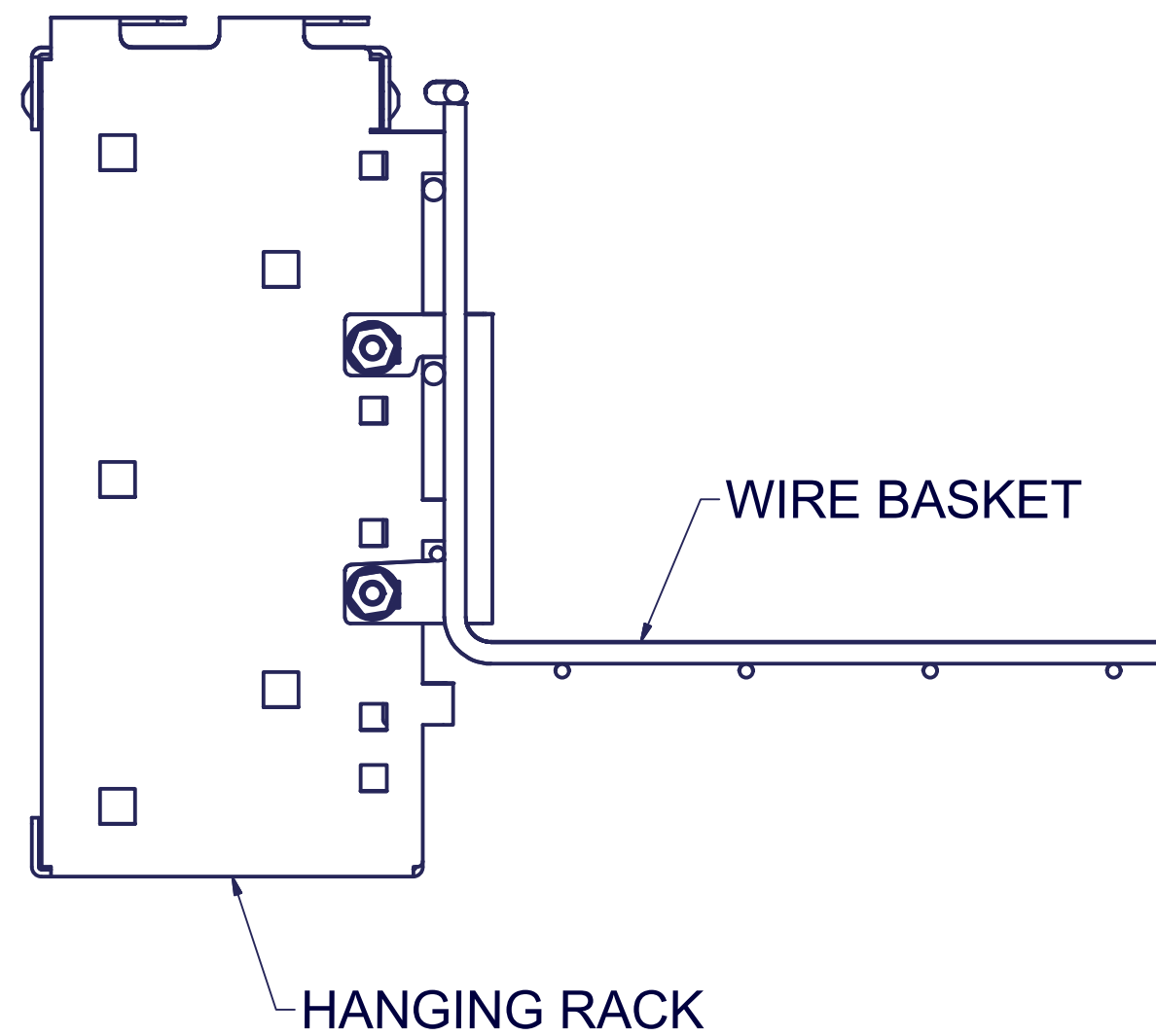

FLUSH MOUNTING

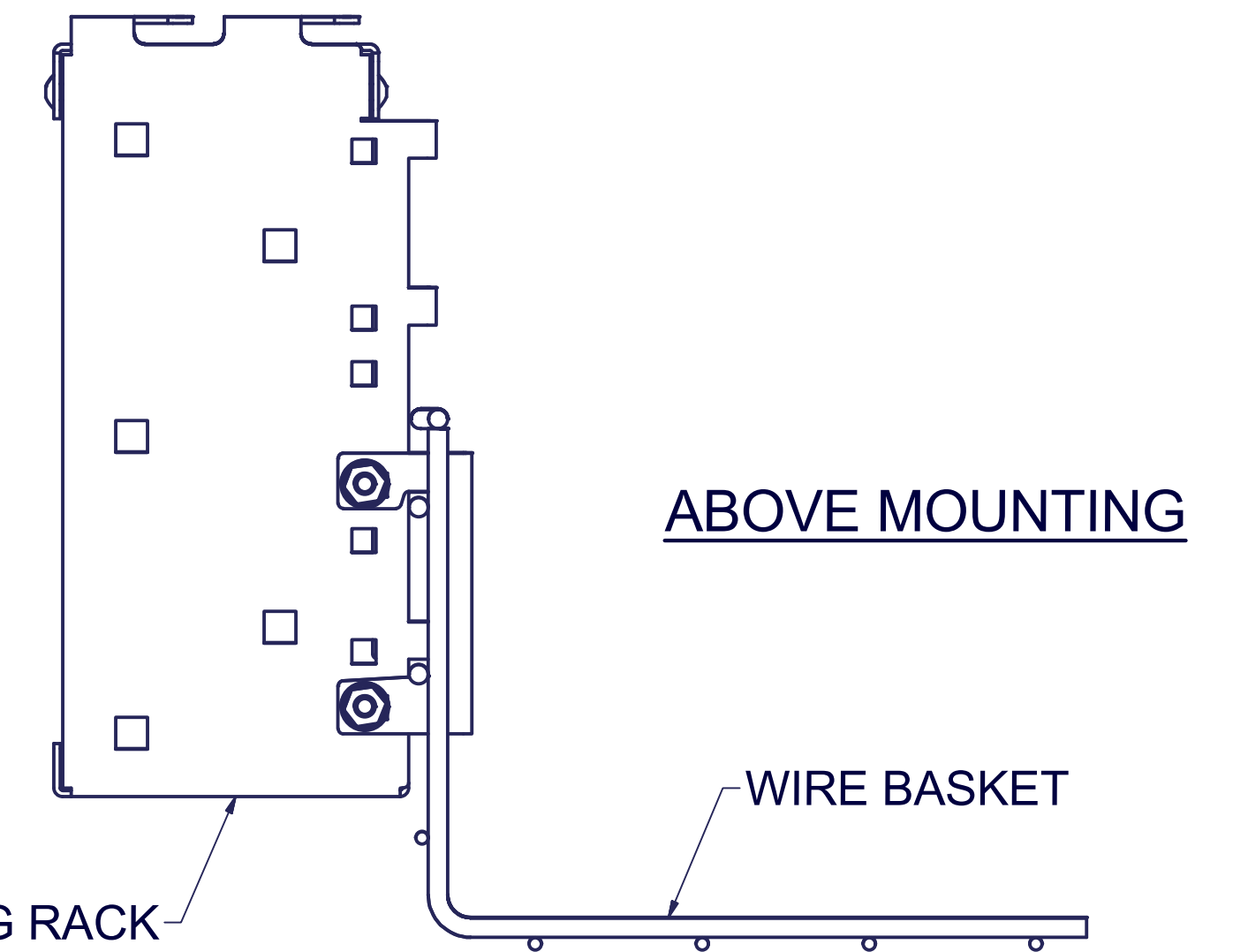

ABOVE MOUNTING

HANGING RACK INSTALLATION OPTIONS



INTERPRET DRAWING PER ASME Y14.5M-1994
DIMENSIONAL LIMITS APPLY AFTER APPLICATION OF FINISH
DRAWING NOT TO SCALE
TOLERANCE UNLESS OTHERWISE NOTED:
ANGULAR +/- .1°
.XXXX +/- .010
.XXX +/- .015
.XX +/- .030
.X FOR REF. ONLY
UNLESS OTHERWISE SPECIFIED ALL DIMENSIONS ARE IN INCHES

NOTICE:
Use of this document is subject to a confidentiality and nondisclosure agreement with Great Lakes Case & Cabinet Co., Inc. (GLCC) and may not be reproduced, disclosed or utilized in whole or in part without prior written authorization from GLCC.

PART NUMBER:	UCRHRS
MATERIAL TYPE:	-
MATERIAL GAUGE:	-
FINISH:	-
DRAWN	DATE
CAIUSD	10/11/2019
CHECKED & APP.	DATE
CND	10/15/19

TITLE	UCRHRS INSTALLATION OPTIONS
GREAT LAKES CASE & CABINET CO., INC. P.O. BOX 551 EDINBORO, PA 16412 PHONE (814) 734-7303 FAX (814) 734-3907 E-MAIL glcc@greatcabinets.com	
DWG NO:	MS-5.02-72
REV	
SHEET:	1 OF 3

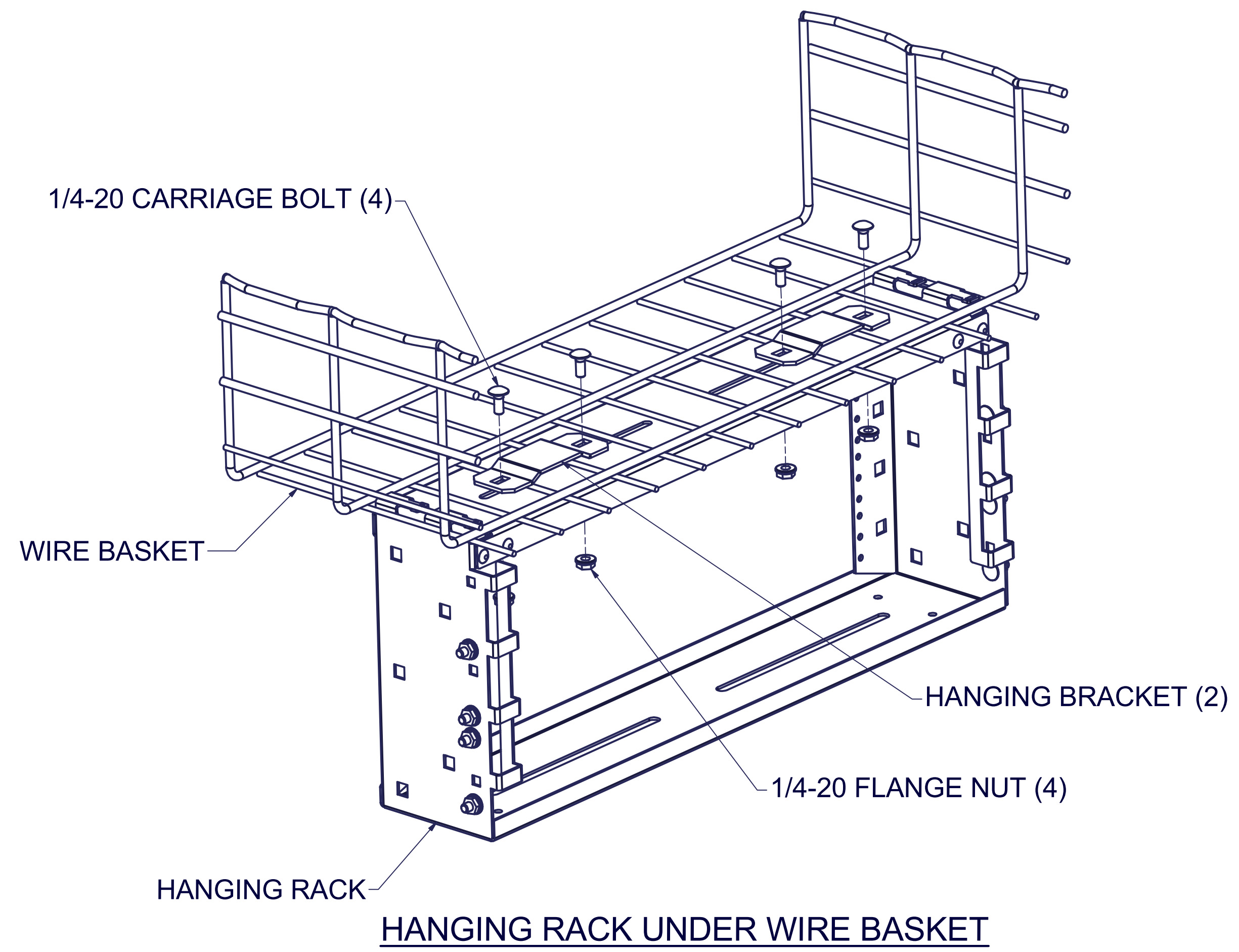

HANGING RACK INSTALLATION STEPS (UNDER WIRE BASKET OR LADDER):

1. IDENTIFY HANGING BRACKETS TO HOLD HANGING RACK.
2. USE 1/4-20 CARRIAGE BOLTS AND 1/4-20 FLANGED LOCK NUT TO ATTACH SYSTEM.
3. ALIGN HANGING RACK UNDER WIRE BASKET OR LADDER.
4. HOLD IN PLACE WITH HANGING BRACKETS AND 1/4-20 BOLTS AND NUTS AS SHOWN.

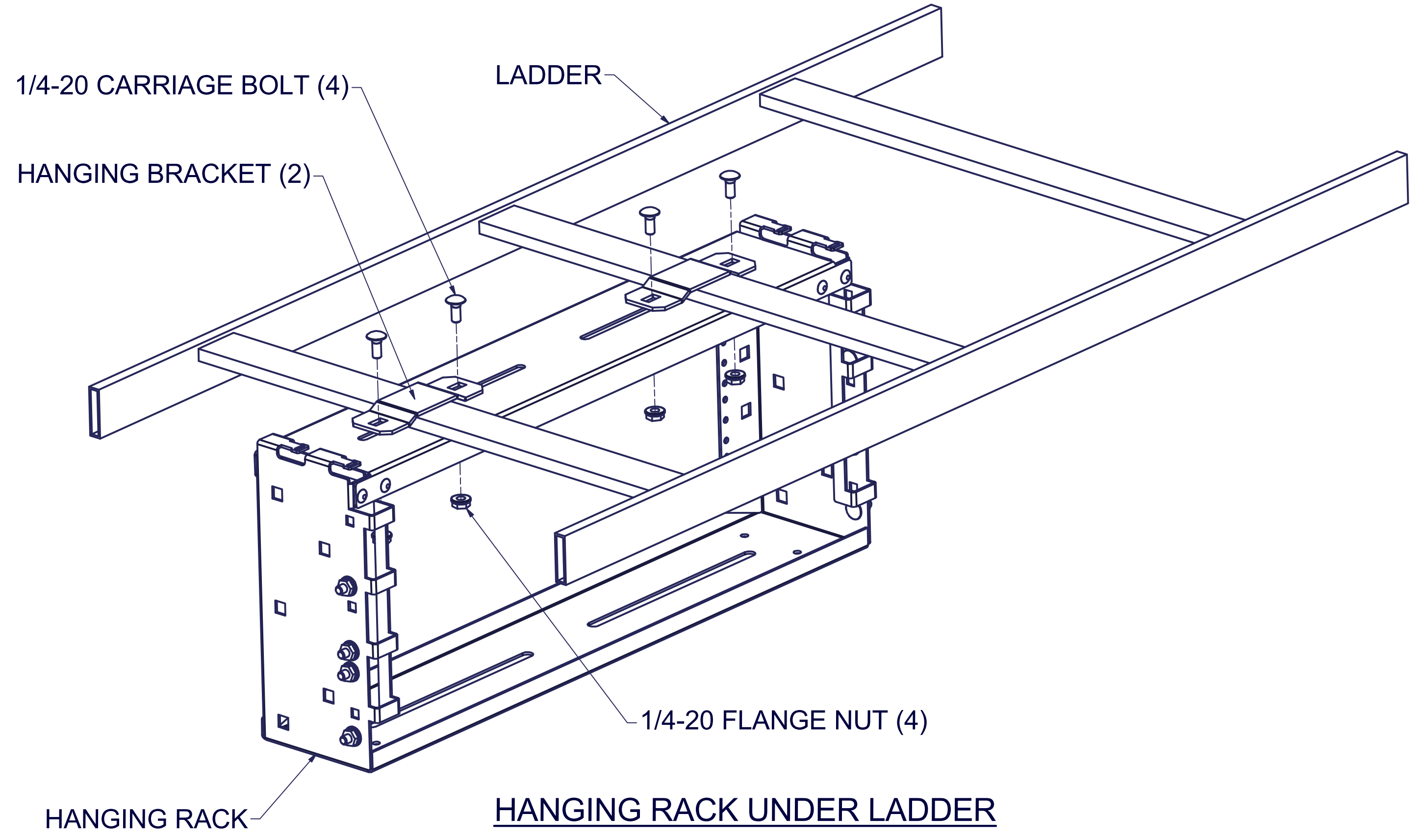

EST. WEIGHT :
N/A



INTERPRET DRAWING PER ASME Y14.5M-1994
DIMENSIONAL LIMITS APPLY
AFTER APPLICATION OF FINISH
DRAWING NOT TO SCALE
TOLERANCE UNLESS OTHERWISE NOTED:
ANGULAR +/- .1°
.XXXX +/- .010
.XXX +/- .015
.XX +/- .030
.X FOR REF. ONLY
UNLESS OTHERWISE SPECIFIED
ALL DIMENSIONS ARE IN INCHES

NOTICE:
Use of this document is subject to a confidentiality and nondisclosure agreement with Great Lakes Case & Cabinet Co., Inc. (GLCC) and may not be reproduced, disclosed or utilized in whole or in part without prior written authorization from GLCC.

PART NUMBER:
UCRHRS
MATERIAL TYPE:
-
MATERIAL GAUGE:
-
FINISH:
-
DRAWN DATE
CALUSD 10/11/2019
CHECKED & APP. DATE
CND 10/15/19

TITLE
UCRHRS INSTALLATION OPTIONS
GREAT LAKES CASE & CABINET CO., INC.
P.O. BOX 551 EDINBORO, PA 16412
PHONE (814) 734-7303 FAX (814) 734-3907
E-MAIL glcc@greatcabinets.com
DWG NO:
MS-5.02-72
REV
SHEET: 2 OF 3

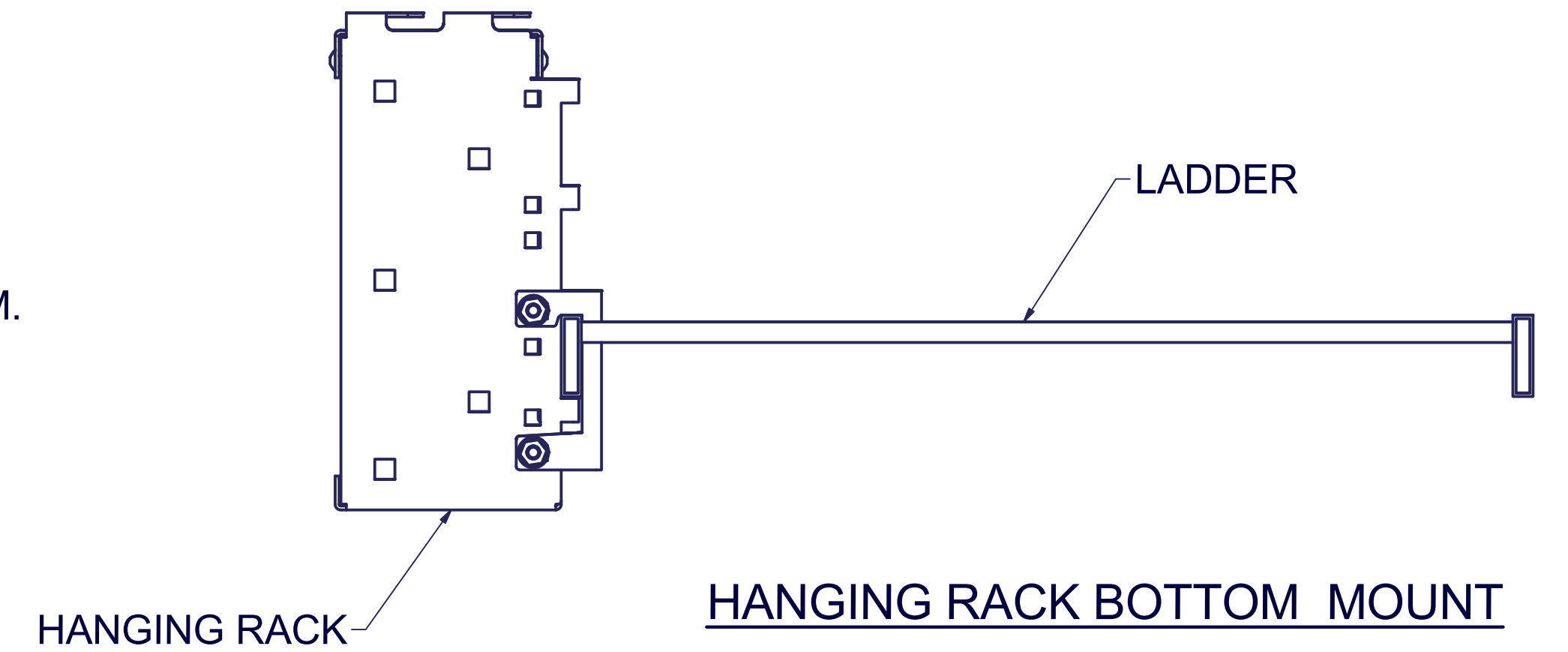
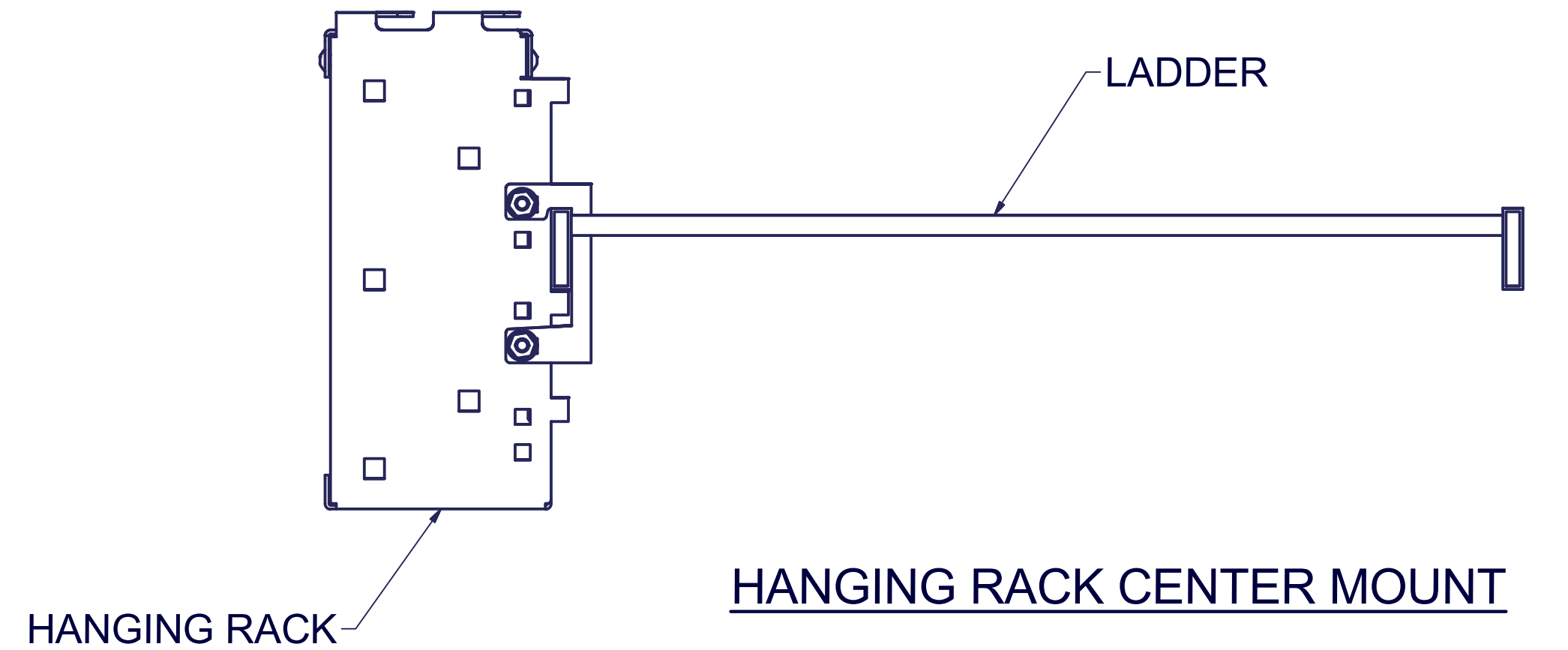
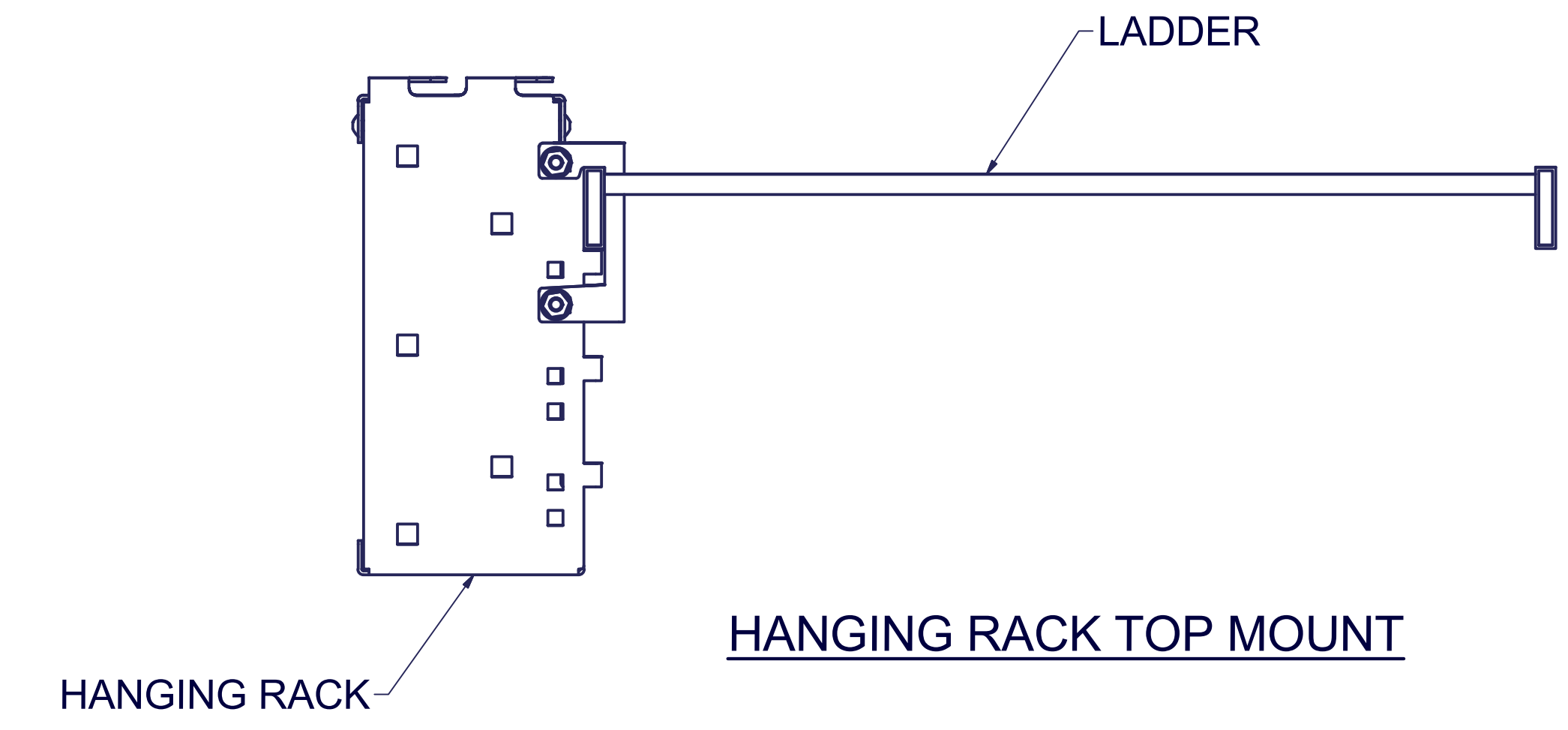
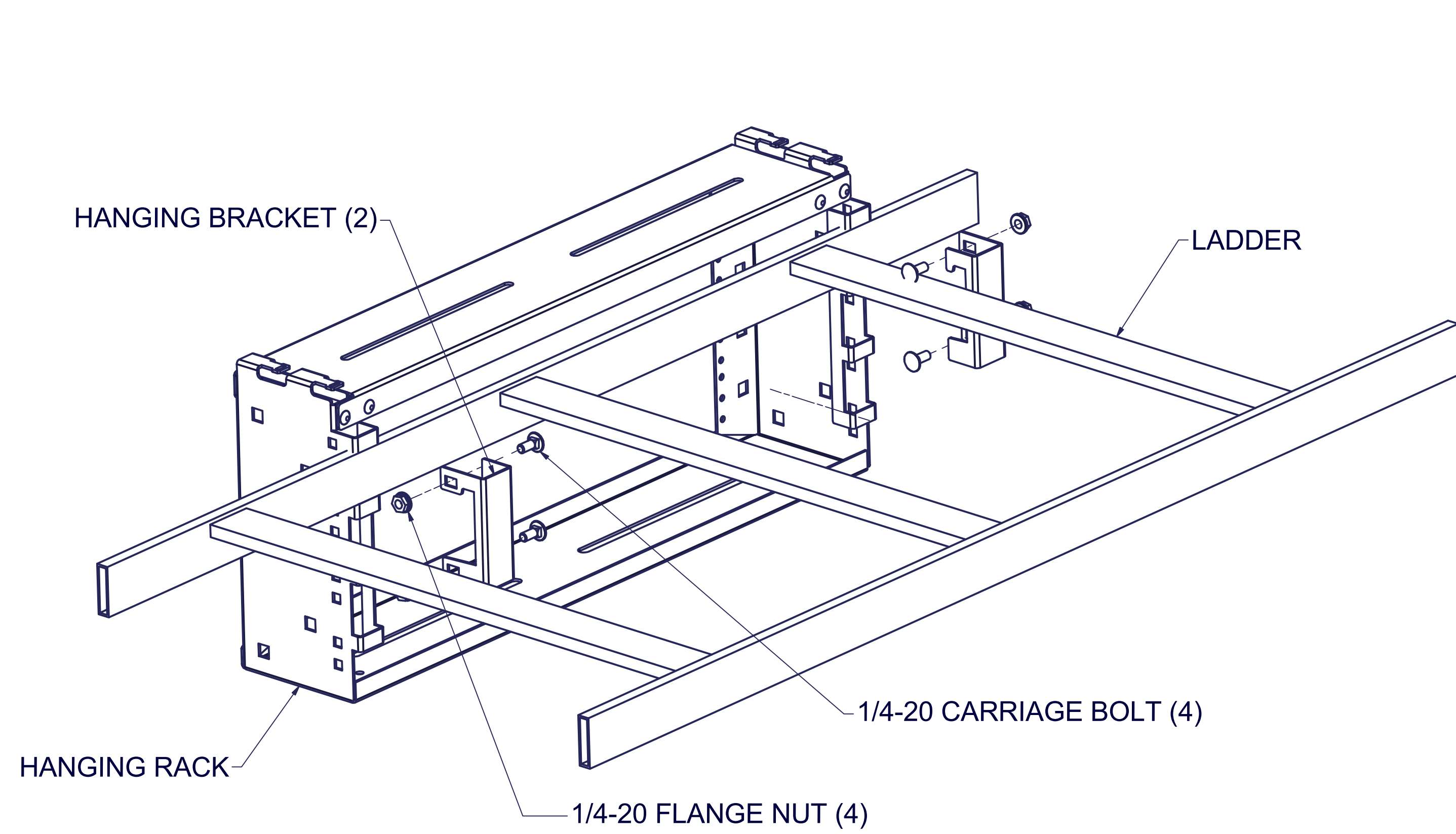

HANGING RACK INSTALLATION STEPS (ON SIDE OF LADDER):

1. IDENTIFY HANGING BRACKETS TO HOLD HANGING RACK.
2. USE 1/4-20 CARRIAGE BOLTS AND 1/4-20 FLANGED LOCK NUT TO ATTACH SYSTEM.
3. ALIGN HANGING RACK ON SIDE OF LADDER AT DESIRED POSITION, TOP, CENTER, OR BOTTOM.
4. HOLD IN PLACE WITH HANGING BRACKETS AND 1/4-20 BOLTS AND NUTS AS SHOWN.

EST. WEIGHT :
N/A



INTERPRET DRAWING PER ASME Y14.5M-1994
DIMENSIONAL LIMITS APPLY
AFTER APPLICATION OF FINISH
DRAWING NOT TO SCALE
TOLERANCE UNLESS OTHERWISE NOTED:
ANGULAR +/- 1°
.XXXX +/- .010
.XXX +/- .015
.XX +/- .030
.X FOR REF. ONLY
UNLESS OTHERWISE SPECIFIED
ALL DIMENSIONS ARE IN INCHES

NOTICE:
Use of this document is subject to a confidentiality and nondisclosure agreement with Great Lakes Case & Cabinet Co., Inc. (GLCC) and may not be reproduced, disclosed or utilized in whole or in part without prior written authorization from GLCC.

PART NUMBER:
UCRHRS
MATERIAL TYPE:
-
MATERIAL GAUGE:
-
FINISH:
-
DRAWN DATE: 10/11/2019
CAIUSD DATE: 10/11/2019
CHECKED & APP. DATE: 10/15/19
CND

TITLE
UCRHRS INSTALLATION OPTIONS
GREAT LAKES CASE & CABINET CO., INC.
P.O. BOX 551 EDINBORO, PA 16412
PHONE (814) 734-7303 FAX (814) 734-3907
E-MAIL glcc@greatcabinets.com
DWG NO: **MS-5.02-72**
REV
SHEET: 3 OF 3