

(4 RMU) #12-24 UNC TAPPED TILT-OUT BRACKET SET

(2 & 4 RMU) #12-24 UNC TAPPED STAGGER BRACKET SET

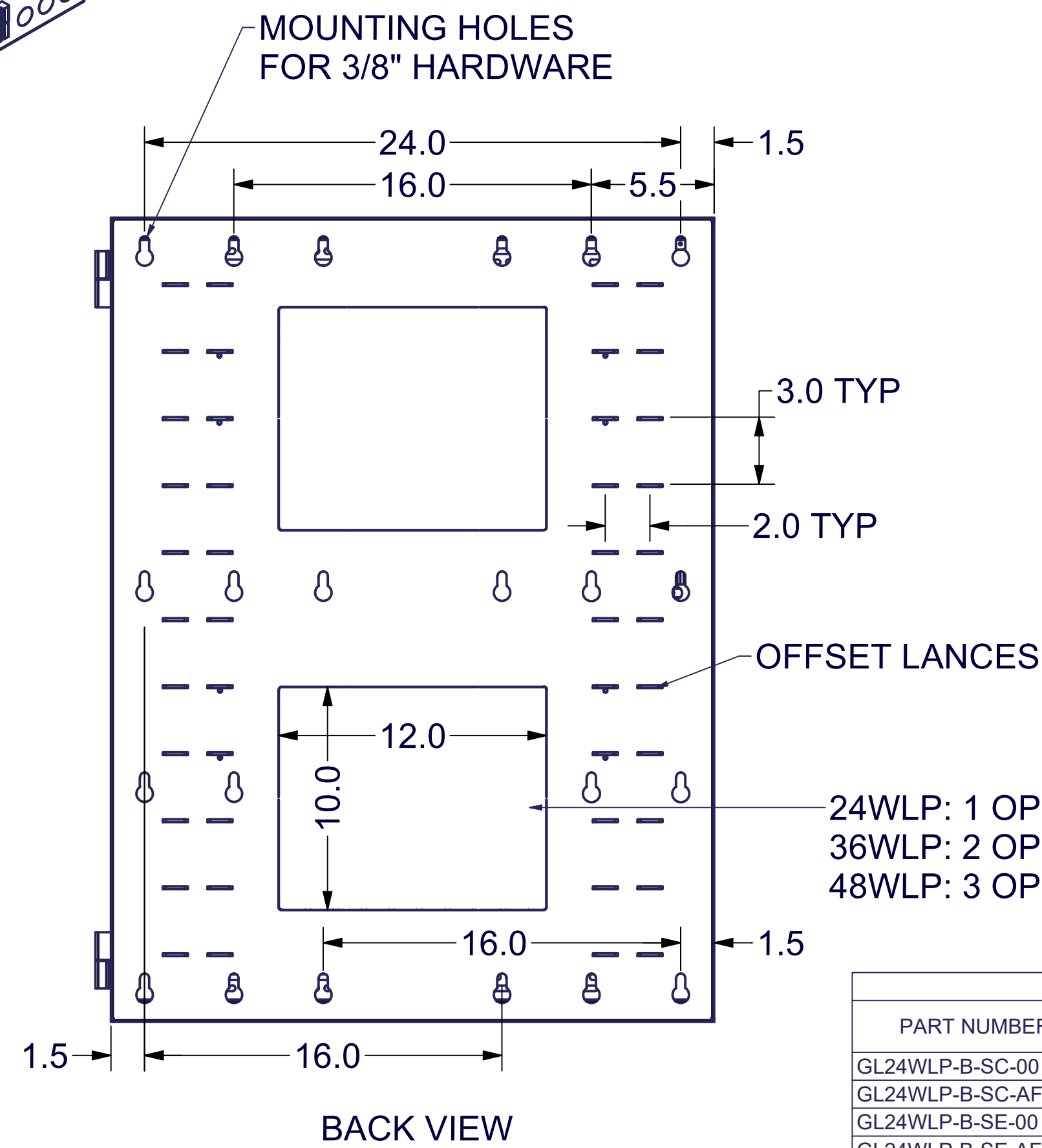
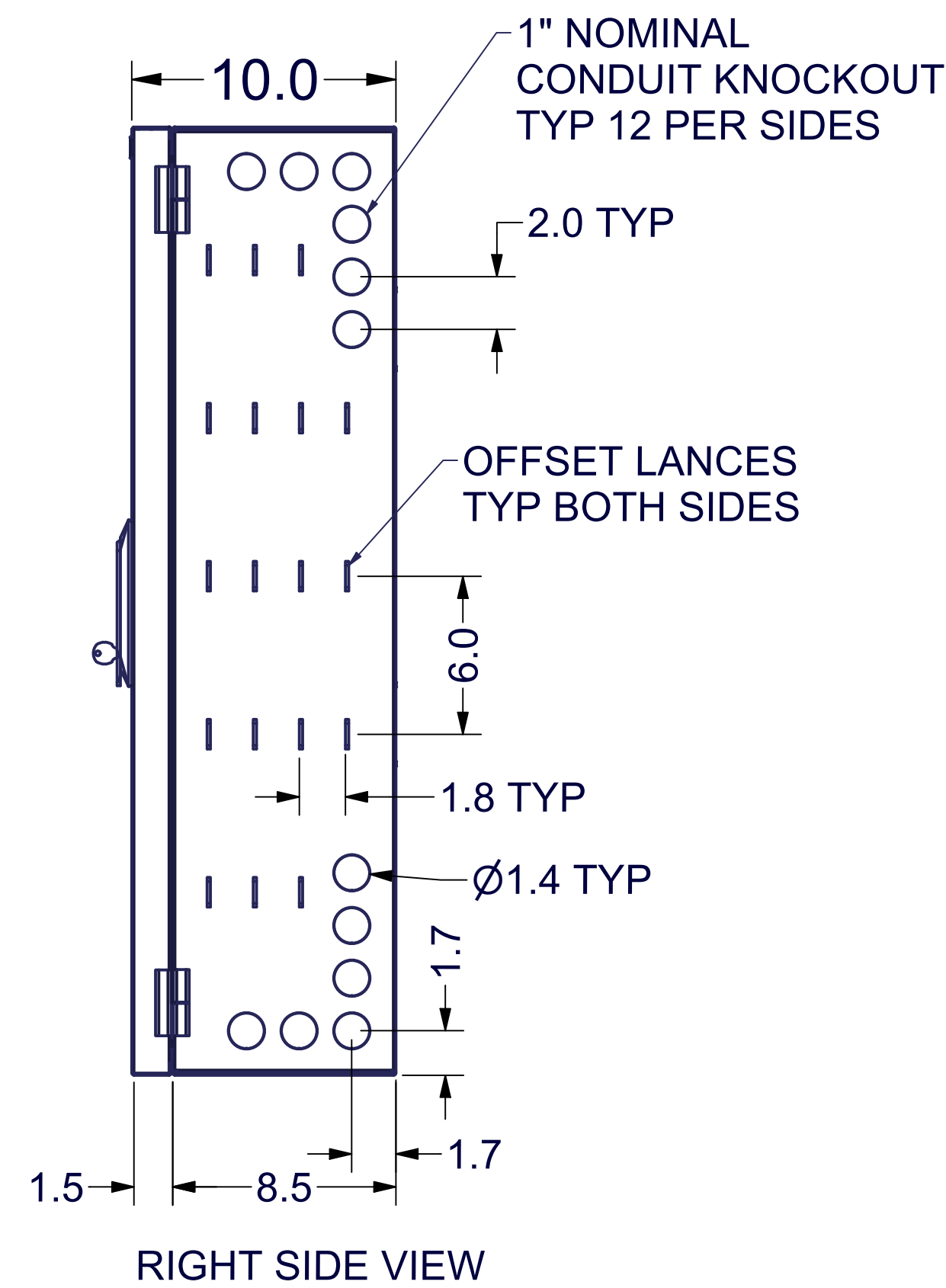
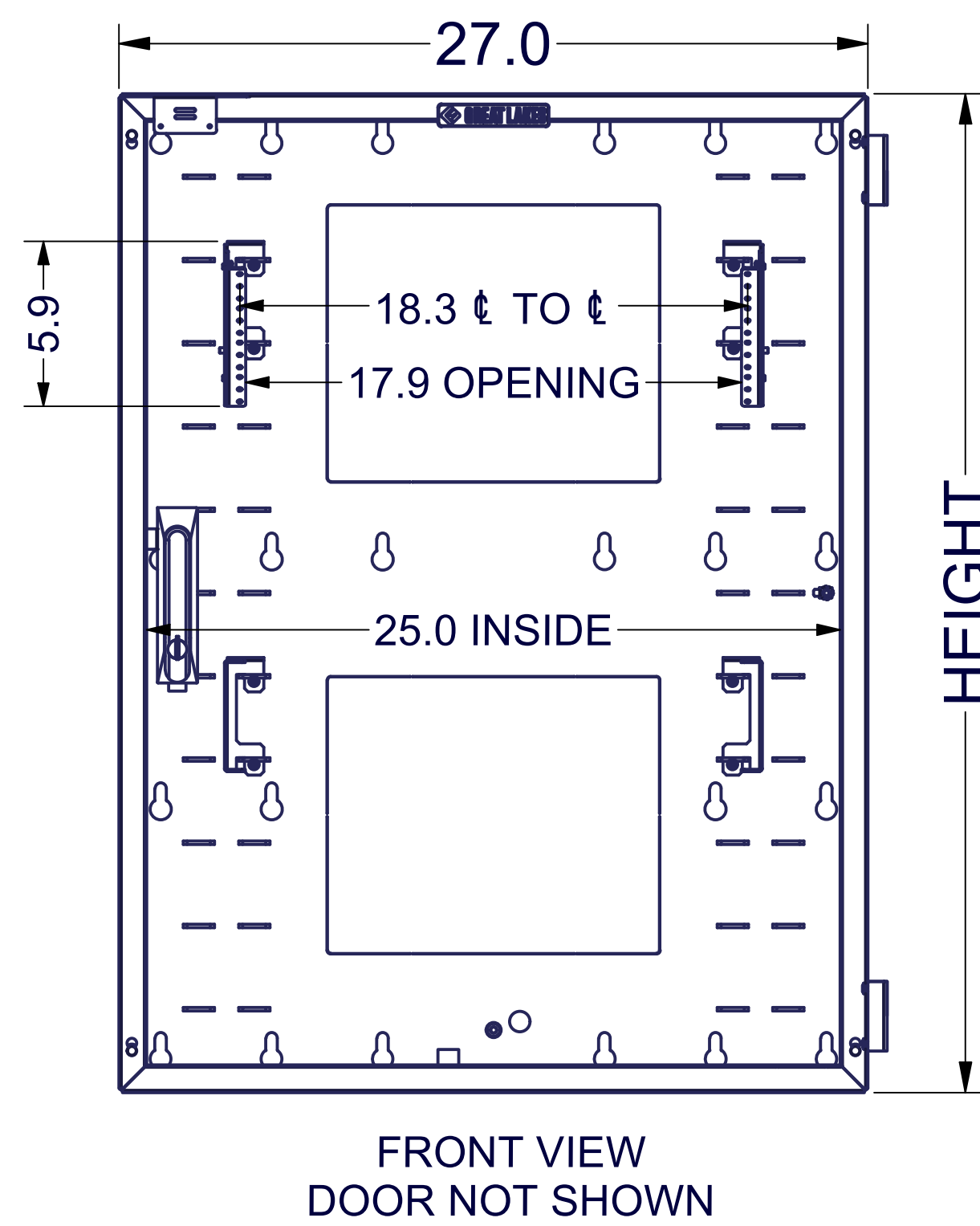
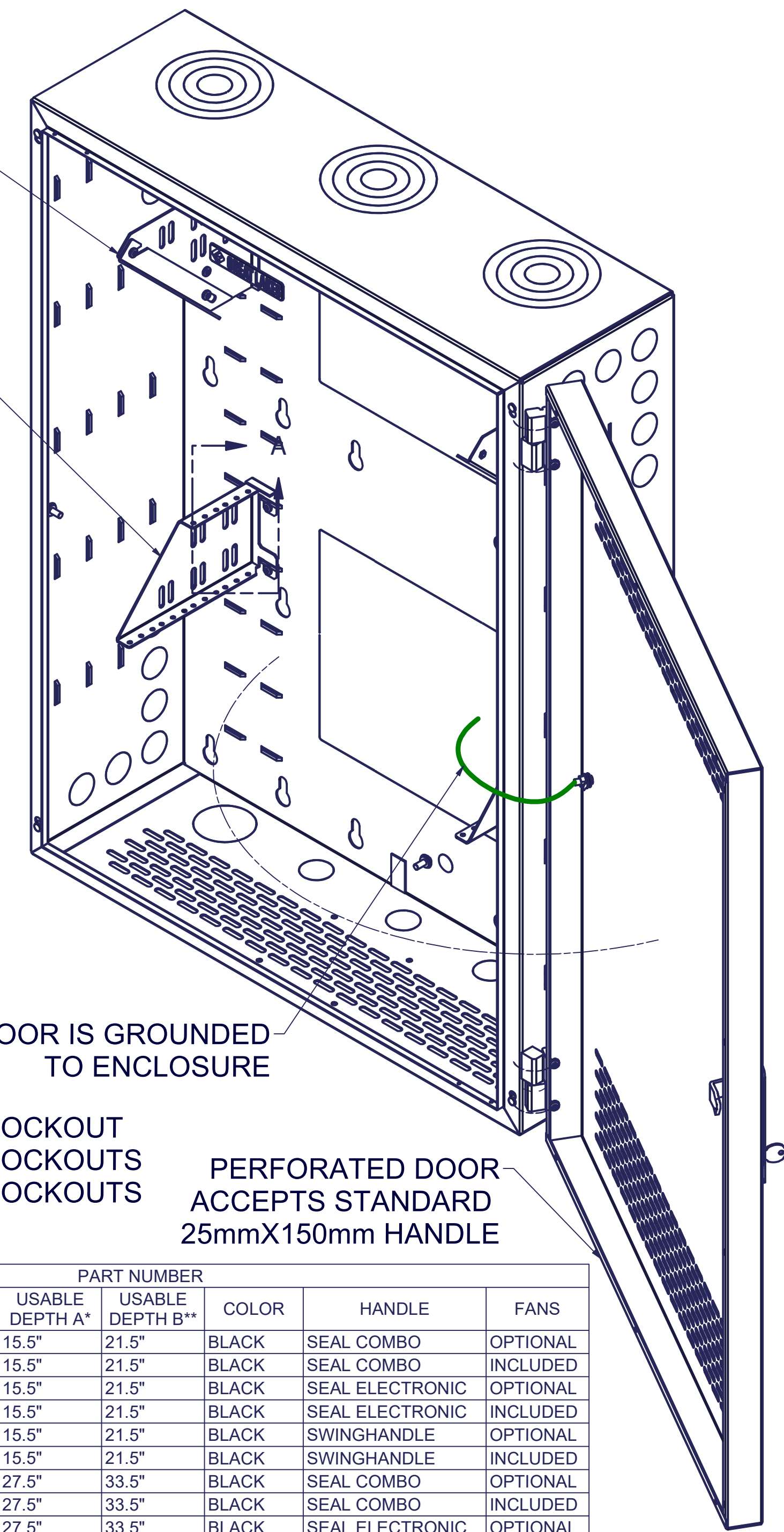

24WLP: 1 OPTIONAL KNOCKOUT
36WLP: 2 OPTIONAL KNOCKOUTS
48WLP: 3 OPTIONAL KNOCKOUTS

PART NUMBER						
PART NUMBER	HEIGHT	USABLE DEPTH A*	USABLE DEPTH B**	COLOR	HANDLE	FANS
GL24WLP-B-SC-00	24.0"	15.5"	21.5"	BLACK	SEAL COMBO	OPTIONAL
GL24WLP-B-SC-AF	24.0"	15.5"	21.5"	BLACK	SEAL COMBO	INCLUDED
GL24WLP-B-SE-00	24.0"	15.5"	21.5"	BLACK	SEAL ELECTRONIC	OPTIONAL
GL24WLP-B-SE-AF	24.0"	15.5"	21.5"	BLACK	SEAL ELECTRONIC	INCLUDED
GL24WLP-B-SH-00	24.0"	15.5"	21.5"	BLACK	SWINGHANDLE	OPTIONAL
GL24WLP-B-SH-AF	24.0"	15.5"	21.5"	BLACK	SWINGHANDLE	INCLUDED
GL36WLP-B-SC-00	36.0"	27.5"	33.5"	BLACK	SEAL COMBO	OPTIONAL
GL36WLP-B-SC-AF	36.0"	27.5"	33.5"	BLACK	SEAL COMBO	INCLUDED
GL36WLP-B-SE-00	36.0"	27.5"	33.5"	BLACK	SEAL ELECTRONIC	OPTIONAL
GL36WLP-B-SE-AF	36.0"	27.5"	33.5"	BLACK	SEAL ELECTRONIC	INCLUDED
GL36WLP-B-SH-00	36.0"	27.5"	33.5"	BLACK	SWINGHANDLE	OPTIONAL
GL36WLP-B-SH-AF	36.0"	27.5"	33.5"	BLACK	SWINGHANDLE	INCLUDED
GL48WLP-B-SC-00	48.0"	39.5"	45.5"	BLACK	SEAL COMBO	OPTIONAL
GL48WLP-B-SC-AF	48.0"	39.5"	45.5"	BLACK	SEAL COMBO	INCLUDED
GL48WLP-B-SE-00	48.0"	39.5"	45.5"	BLACK	SEAL ELECTRONIC	OPTIONAL
GL48WLP-B-SE-AF	48.0"	39.5"	45.5"	BLACK	SEAL ELECTRONIC	INCLUDED
GL48WLP-B-SH-00	48.0"	39.5"	45.5"	BLACK	SWINGHANDLE	OPTIONAL
GL48WLP-B-SH-AF	48.0"	39.5"	45.5"	BLACK	SWINGHANDLE	INCLUDED

*USABLE DEPTH 'A' CONSIDERS ENCLOSURE USED WITH 4 RU TILT OUT BRACKETS
**USABLE DEPTH 'B' CONSIDERS ENCLOSURE USED WITH ONLY 1 SET OF STAGGER RAIL BRACKETS

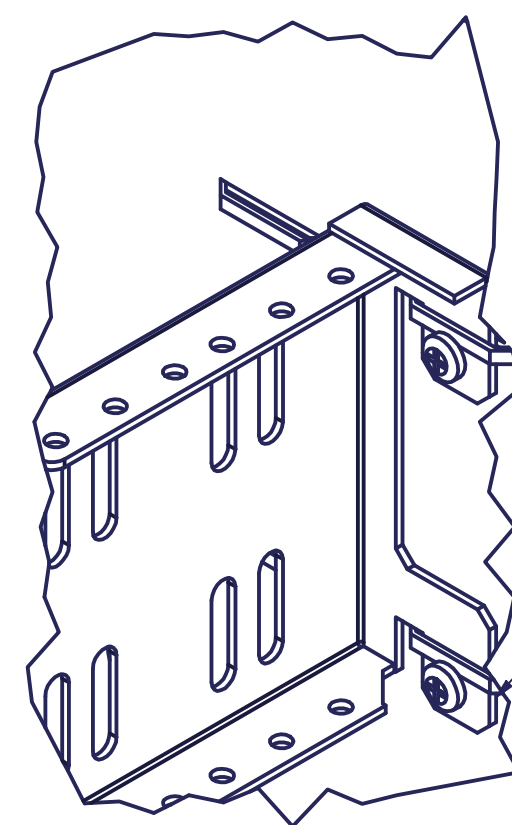
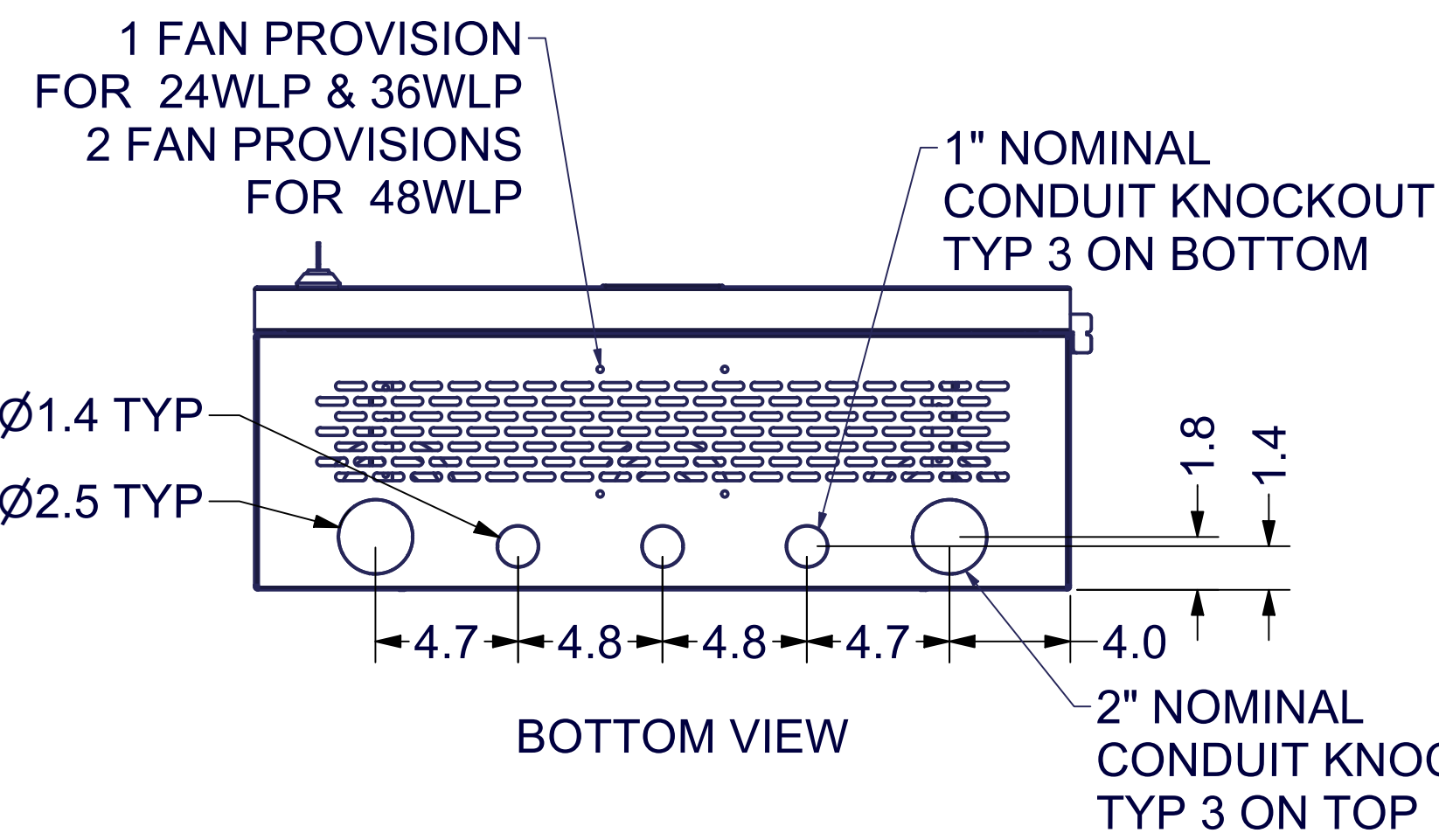

COMPONENT HOOKS SLIDE INTO OFFSET LANCES ON THE REAR OF THE ENCLOSURE AND ARE RETAINED IN POSITION BY SCREWS (FIELD ADJUSTABLE)

EST. WEIGHT: N/A

THIRD ANGLE PROJECTION

INTERPRET DRAWING PER ASME Y14.5M-1994
DIMENSIONAL LIMITS APPLY AFTER APPLICATION OF FINISH
DRAWING NOT TO SCALE
TOLERANCE UNLESS OTHERWISE NOTED:
ANGULAR +/- .1"
.XXXX +/- .010
.XXX +/- .015
.XX +/- .030
.X FOR REF. ONLY

UNLESS OTHERWISE SPECIFIED ALL DIMENSIONS ARE IN INCHES

NOTICE:
Use of this document is subject to a confidentiality and nondisclosure agreement with Great Lakes Case & Cabinet Co., Inc. (GLCC) and may not be reproduced, disclosed or utilized in whole or in part without prior written authorization from GLCC.

PART NUMBER: GLXXWLP-B-XX-XX
TITLE: WLP SERIES WALL MOUNT
MATERIAL TYPE:
MATERIAL GAUGE:
FINISH:
DRAWN: DATE: 9/2/2015
CHECKED & APP. DATE:
DWG NO.: WLP
REV:
SHEET: 1 OF 1

GREAT LAKES CASE & CABINET CO., INC.
P.O. BOX 551 EDINBORO, PA 16412
PHONE (814) 734-7303 FAX (814) 734-3907
E-MAIL glcc@greatcabinets.com