

WALL MOUNT FLAT PACK

FAST ASSEMBLY AND OPEN DESIGN FOR QUICK EQUIPMENT INSTALLATION

Fan Assembly

Optional 75
CFM fan

Reversible Mesh Door

with keyed lock



Flat Pack

Ships flat packed and
assembles with minimal
effort!

Side Panel

Swings outward for
equipment access

Part No.	RMU	H" (mm)	W" (mm)	D" (mm)	Usable Depth in. (mm)	Max. Rail Depth in. (mm)	Airflow
GL06WMFP-B-00	6	12.65" (321)	23.62" (600)	17.12" (450)	16.73" (425)	15.19" (386)	Fan not included
GL06WMFP-B-AF	6	12.65" (321)	23.62" (600)	17.12" (450)	16.73" (425)	15.19" (386)	Fan Included
GL09WMFP-B-00	9	17.8" (454)	23.62" (600)	17.12" (450)	16.73" (425)	15.19" (386)	Fan not included
GL09WMFP-B-AF	9	17.8" (454)	23.62" (600)	17.12" (450)	16.73" (425)	15.19" (386)	Fan Included

FEATURES

- Fast and efficient assembly
- Flat packed for onsite storage
- Open design for easy equipment installation and maintenance
- Reversible mesh door with locking cam
- Hinged side panels (which can only be opened from inside) swing open 90 degrees and can be removed if necessary
- Two cable access knockouts on top and bottom
- 6" x 4" (153mm x 102mm) cable access on the rear
- Load capacity 132 lbs (60kg)
- Color: Black

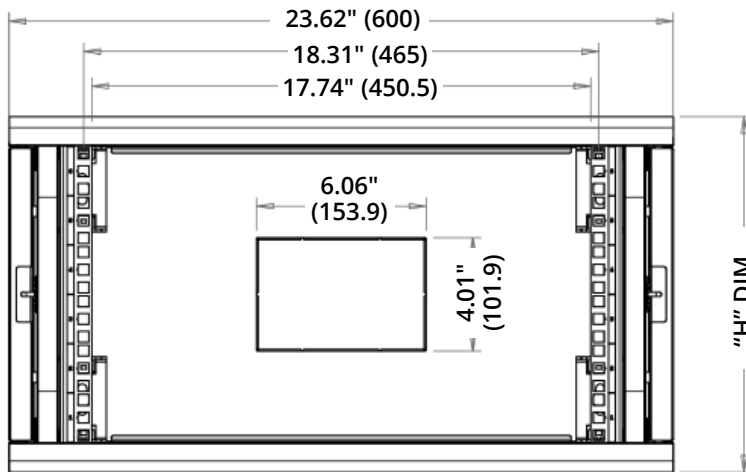
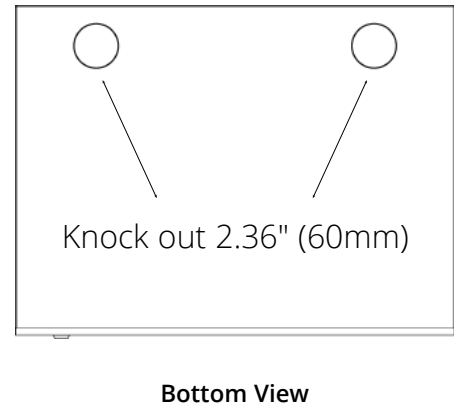
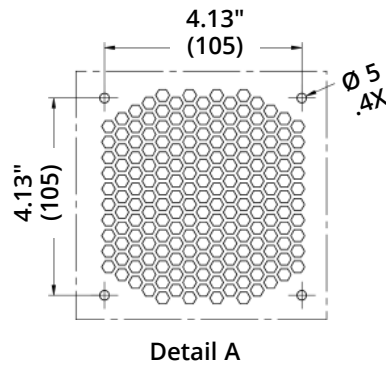
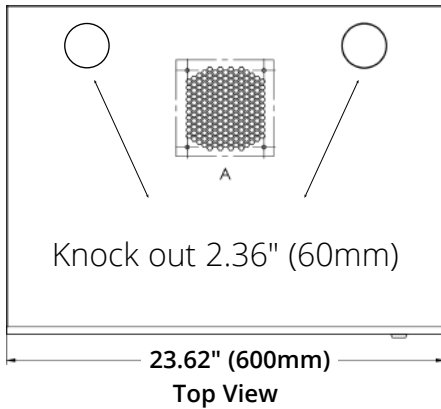

Front view, door removed

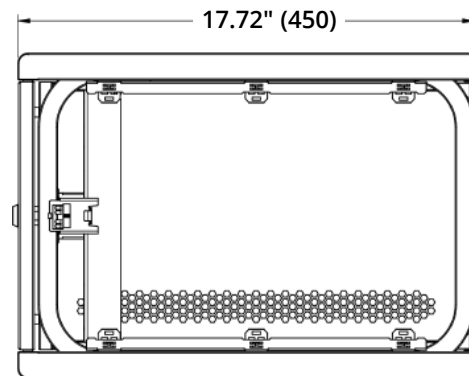

Side view, panel removed