

CONSTRUCTION:

SIMPLE 4 PIECE BOLT TOGETHER CONSTRUCTION
 DURABLE TEXTURE POWDER COAT
 #12 GA. C.R.S. RAIL BRACKETS (1 PAIR)
 #16 GA. C.R.S. LIGHT WEIGHT WALL MOUNTING BODY
 #16 GA. C.R.S. COVER PANEL

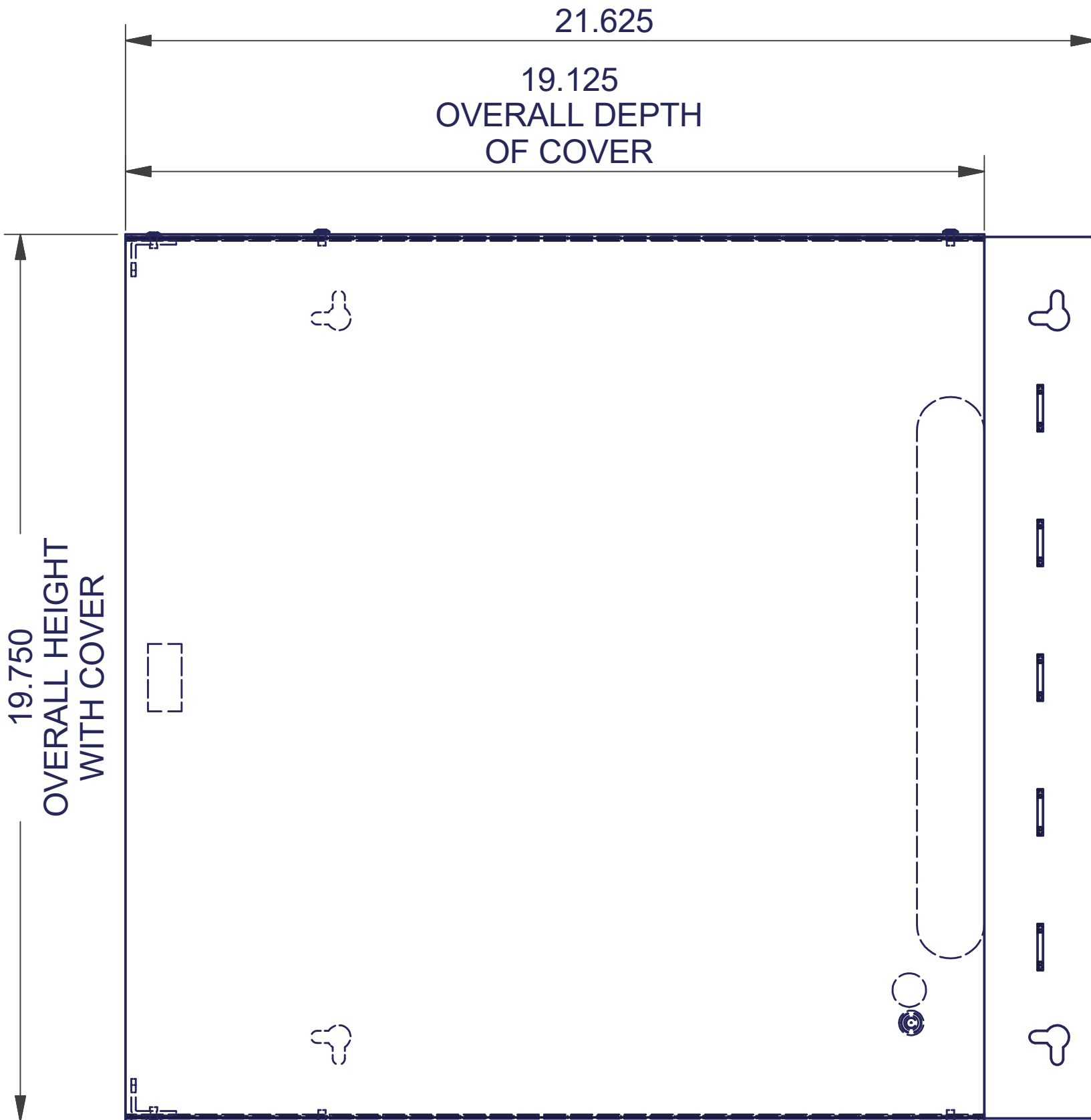
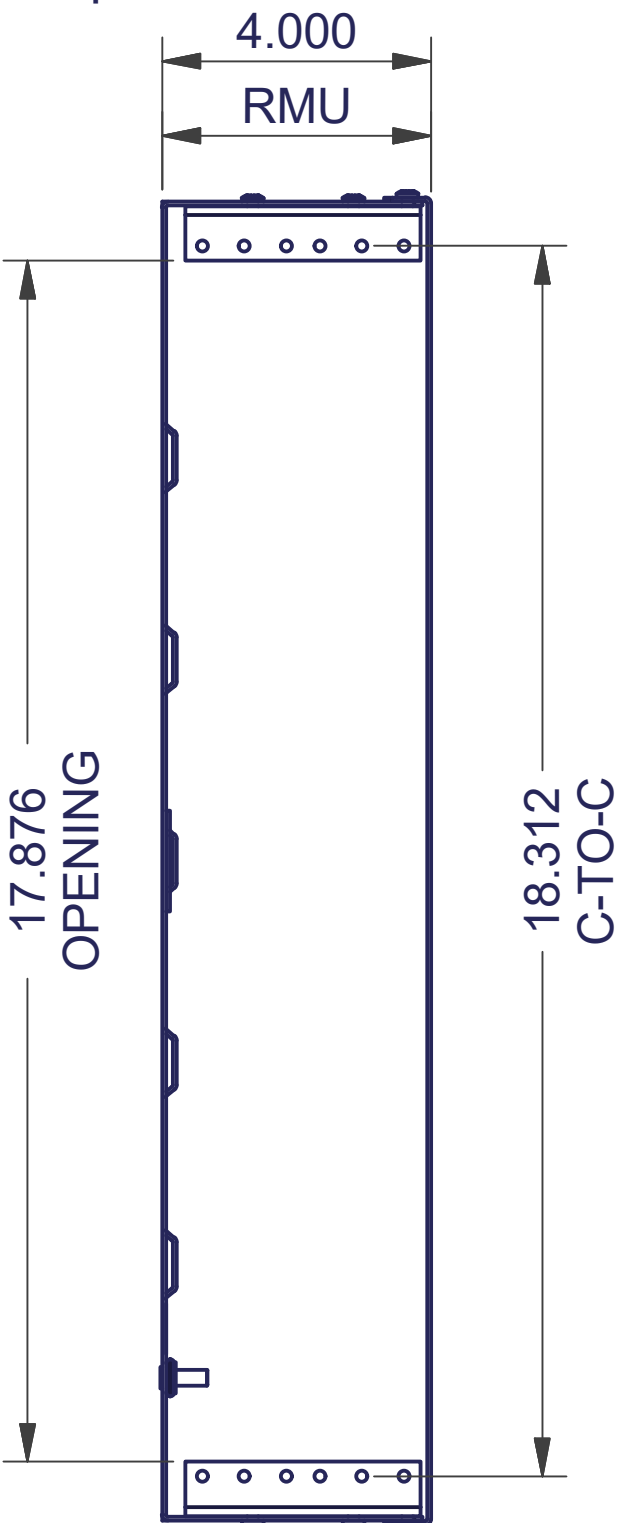
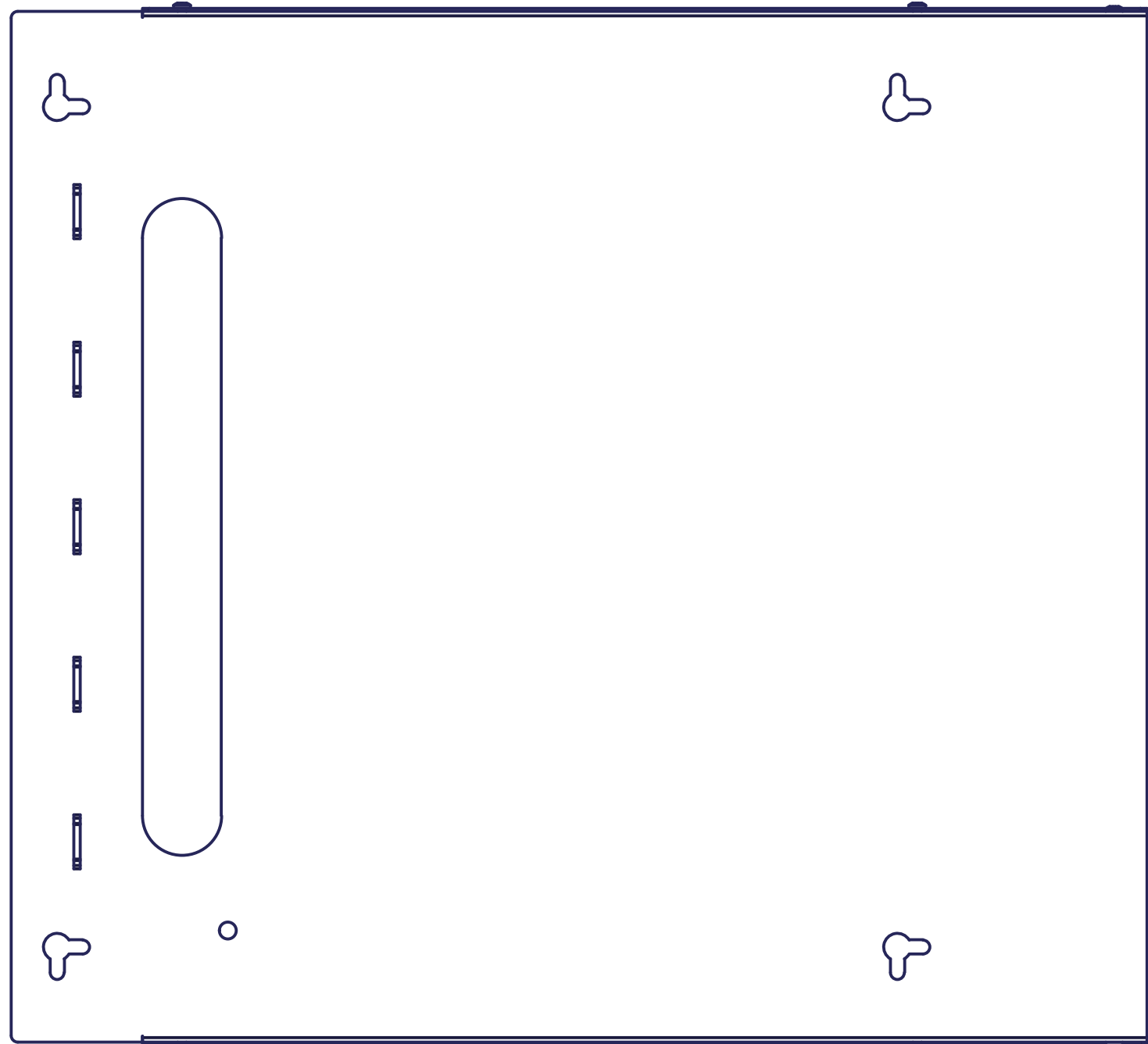
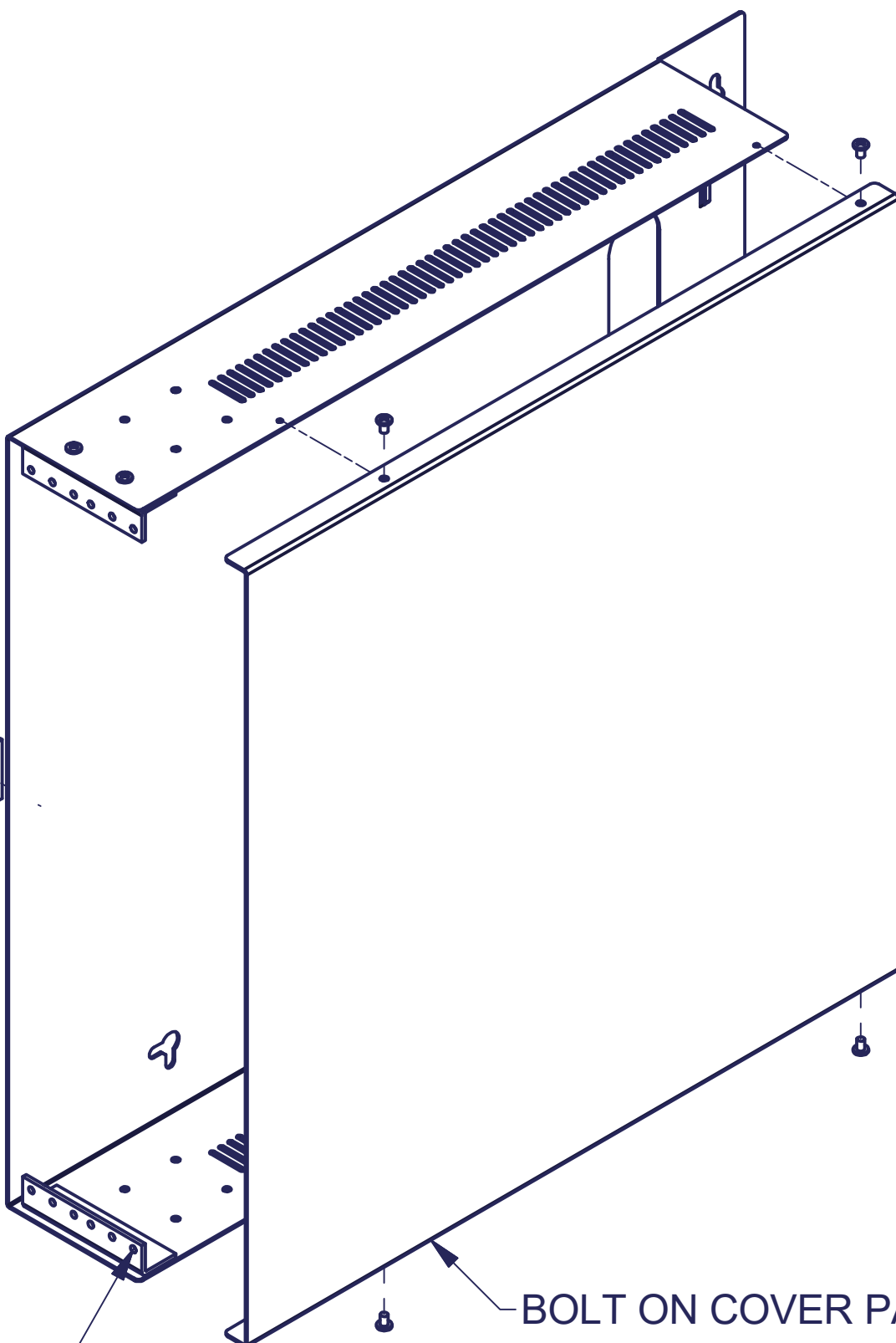

#10-32 TAPPED EIA MTG. HOLES
 BOLT ON COVER PANEL

INTERPRET DRAWING PER ASME Y14.5M-1994
 DIMENSIONAL LIMITS APPLY
 AFTER APPLICATION OF FINISH
 DRAWING NOT TO SCALE
 TOLERANCE UNLESS OTHERWISE NOTED:
 ANGULAR +/- .1°
 .XXXX +/- .010
 .XXX +/- .015
 .XX +/- .030
 .X FOR REF. ONLY

NOTICE:
 Use of this document is subject to a confidentiality and nondisclosure agreement with Great Lakes Case & Cabinet Co., Inc. (GLCC) and may not be reproduced, disclosed or utilized in whole or in part without prior written authorization from GLCC.

PART NUMBER: **WR2X100**
 QTY PER UNIT: 1
 MATERIAL TYPE:
 MATERIAL GAUGE:
 FINISH:
 DRAWN: CA DATE: 10/9/2003
 CHECKED & APP. DATE:

TITLE: **2U WALL RACK, 19" EIA (#10-32), ASSEMBLY**
 GREAT LAKES CASE & CABINET CO., INC.
 P.O. BOX 551 EDINBORO, PA 16412
 PHONE (814) 734-7303 FAX (814) 734-3907
 E-MAIL glcc@greatcabinets.com



THIRD ANGLE PROJECTION
 UNLESS OTHERWISE SPECIFIED ALL DIMENSIONS ARE IN INCHES

REV: 4
 SHEET: 1 OF 1