

REVISION HISTORY			
REV	DESCRIPTION	DATE	APPROVED
0	ECO-01529	3/2/2005	JL
1	ECO-01719	3/23/2006	WSS
2	ECO-01846	1/8/2007	WSS
3	ECO-02227	3/28/2008	JL

Bill of Material					
ITEM	PART NUMBER	QTY	DESCRIPTION	FILE NAME	REV
1	350FPTL19X200	1	19" EIA "TOOL-LESS" FILLER PANEL	350FPTL19X200.ipt	3
2	NY-N6-3-20	4	SOUTHCO PANEL FASTENER, QUARTER TURN, BLACK	NY-N6-3-20.iam	
3	NY-H6-20	4	SOUTHCO PANEL FASTENER, QUARTER TURN HANDLE, BLACK	NY-H6-20.ipt	

SPECIAL NOTES:

- 1) FINISH PER TD-09-103 (POWDER COAT), CLASS B, TEXTURE LEVEL 3, - ALL SURFACES UNLESS OTHERWISE NOTED.
- 2) DIMENSIONS APPLY BEFORE APPLICATION OF FINISH: ADD .005" TO EACH SURFACE FOR INSPECTION.
- 3) ITEM #2 CAPTIVE LATCHES TO BE INSTALLED AS SHOWN (ONLY TWO OF THE ITEM #2 LATCHES ARE REQUIRED FOR PART #175FPTL19X200).
- 4) ITEM #3, HANDLES, EITHER CAN BE INSTALLED ON THE QUARTER TURN FASTENERS OR PLACED IN A SEPARATE SEALED PLASTIC BAG & TAPED TO EACH PANEL.

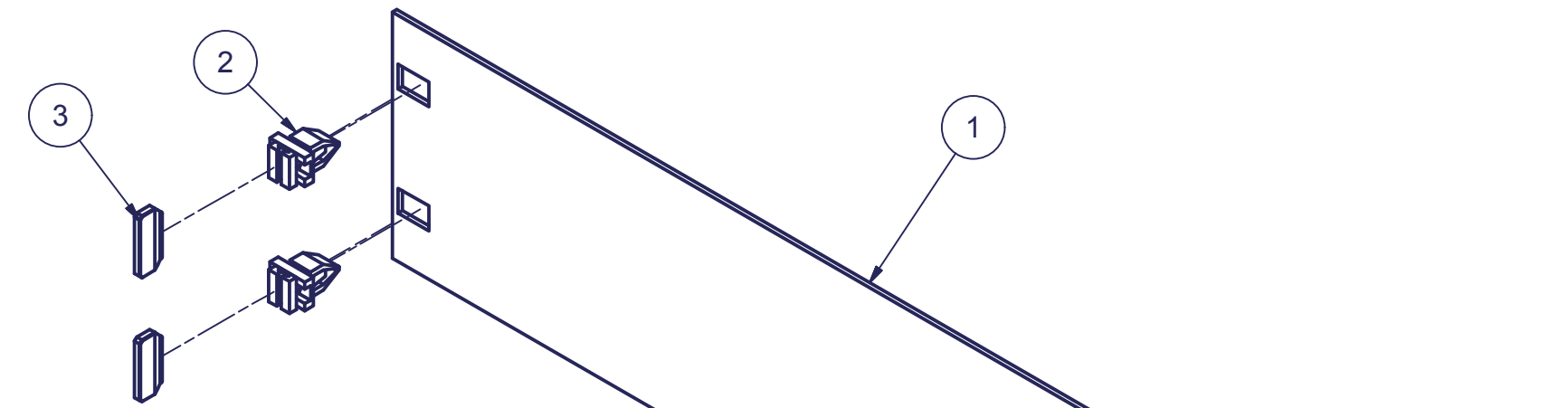

PART #	# OF U's	HEIGHT (in.)	DIM. "A" (in.)	DIM. "B" (in.)
175FPTL19X200	1U	1.719	0	0.859
350FPTL19X200	2U	3.469	1.75	0.859
525FPTL19X200	3U	5.219	2.25	1.485
700FPTL19X200	4U	6.969	4	1.485
875FPTL19X200	5U	8.719	5.75	1.485
1400FPTL19X200	8U	13.969	11	1.485

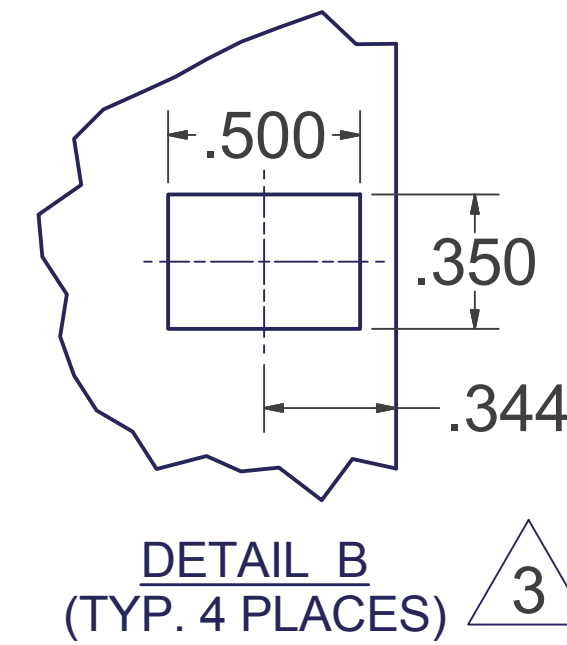

4X 0.350 x 0.500 RECT. 3

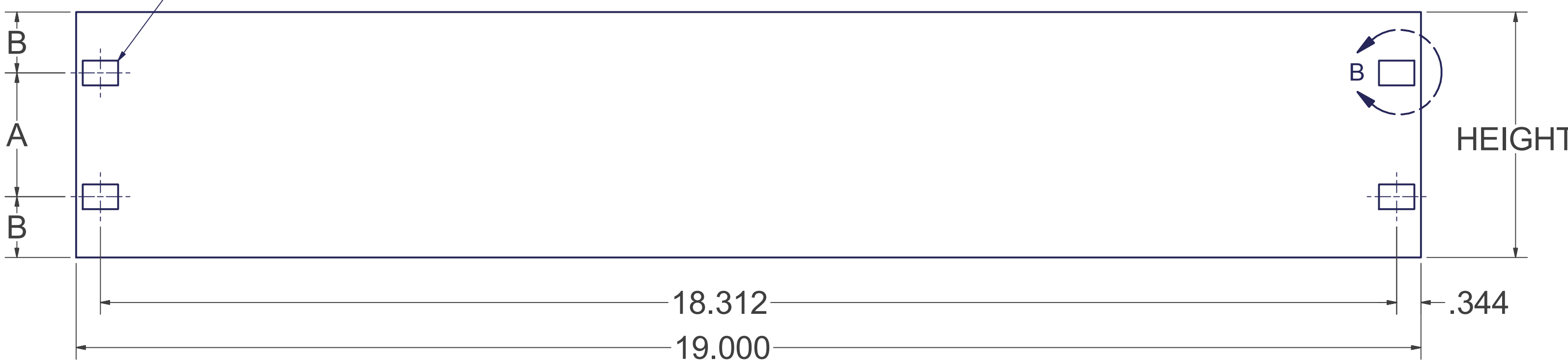

INTERPRET DRAWING PER ASME Y14.5M-1994
 DIMENSIONAL LIMITS APPLY AFTER APPLICATION OF FINISH
 DRAWING NOT TO SCALE
 TOLERANCE UNLESS OTHERWISE NOTED:
 ANGULAR +/- 1'
 .XXXX +/- .010
 .XXX +/- .015
 .XX +/- .030
 .X FOR REF. ONLY
 UNLESS OTHERWISE SPECIFIED ALL DIMENSIONS ARE IN INCHES

NOTICE:
 Use of this document is subject to a confidentiality and nondisclosure agreement with Great Lakes Case & Cabinet Co., Inc. (GLCC) and may not be reproduced, disclosed or utilized in whole or in part without prior written authorization from GLCC.

PART NUMBER:
350FPTL19X200
 QTY PER UNIT: 1
 MATERIAL TYPE: CRS
 MATERIAL GAUGE: 14 GA
 FINISH: SEE NOTES
 DRAWN: Jaye
 CHECKED & APP. WSS
 DATE: 3/2/2005
 DATE: 3-2-05

TITLE
19" EIA "TOOL-LESS" FILLER PANEL
GREAT LAKES CASE & CABINET CO., INC.
 P.O. BOX 551 EDINBORO, PA 16412
 PHONE (814) 734-7303 FAX (814) 734-3907
 E-MAIL glcc@greatcabinets.com
 DWG NO: 1003007
 REV: 3
 SHEET: 1 OF 1

