

## SGLB-0 SIGNATURE SERIES GRADE LEVEL BOX WITH **SELFLOCK™** PROTECTION



# SELFLOCK™

The Signature Series SGLB-0 High Density Polyethylene (HDPE) grade level box line comes standard with Customizable Logo Disk and the Patented **SELFLOCK™** automatic locking mechanism.

### FEATURES

- Designed for Greenbelt/Pedestrian applications
- Captive bolt device, that opens with a  $\frac{1}{4}$  turn
- No bolts to be lost, misplaced, or not installed back into the unit
- Press/Push lid closed, and it will automatically lock in place (with an audible “click”)
- Protects your investment, and ensures the needed protection for your network
- Eliminates the risk of lids floating off, being thrown by lawnmowers (i.e. reduces potential liability)

# SIMPLE AND WORRY FREE PROTECTION



**SELFLOCK** closes and seals with audible "Click"



Captive bolt device opens with only 1/4 turn



Shown with Optional Marker Locate Device

## DIMENSIONS

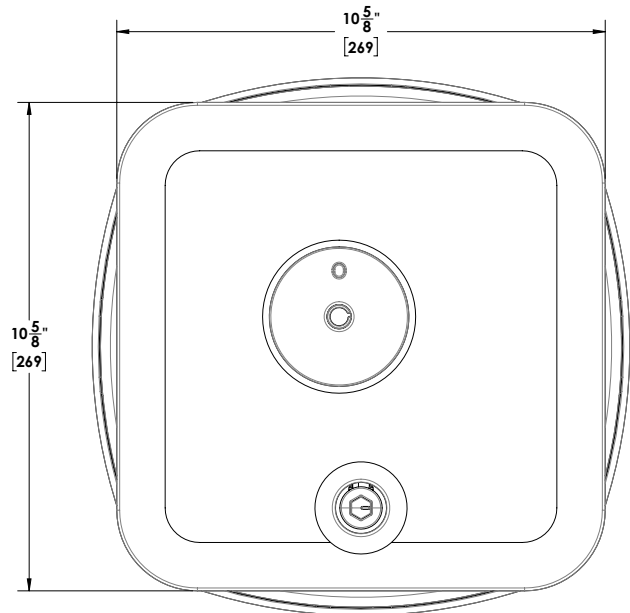
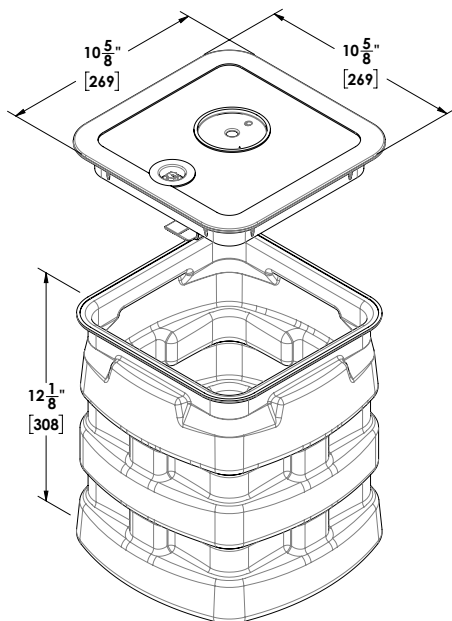

**CHANNELL**

Where The Industry Connects.

[www.channell.com](http://www.channell.com)

All specifications subject to change without notice. © 2024 Channell Commercial Corporation. All rights reserved.