

REV.	ECN #	DESCRIPTION OF CHANGE	DATE	BY	MFG ENG
01	2383	UPDATED ITEMS 1, 2, & 3 / INITIAL RELEASE	07/28/08	L.P.K.	
02	2502	ADDED NOTE 7 / SEE SHEET 2	09/19/11	L.P.K.	
03	2653	REPLACED ITEM #2	03/27/12	L.P.K.	

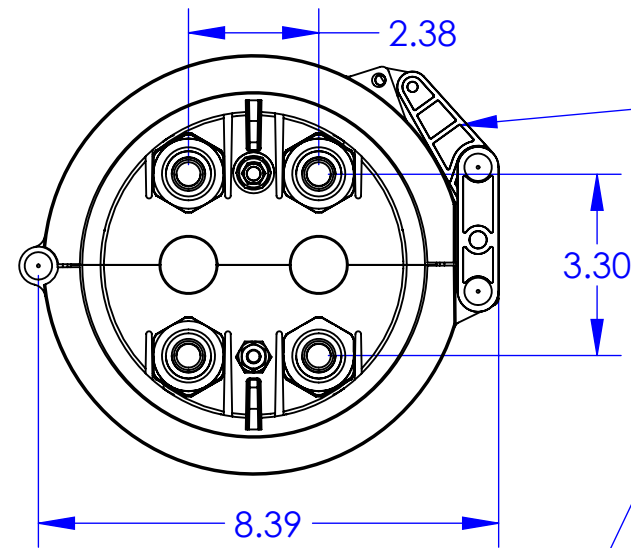

GASKETED SEALING CLAMP WITH PADLOCK OPTION

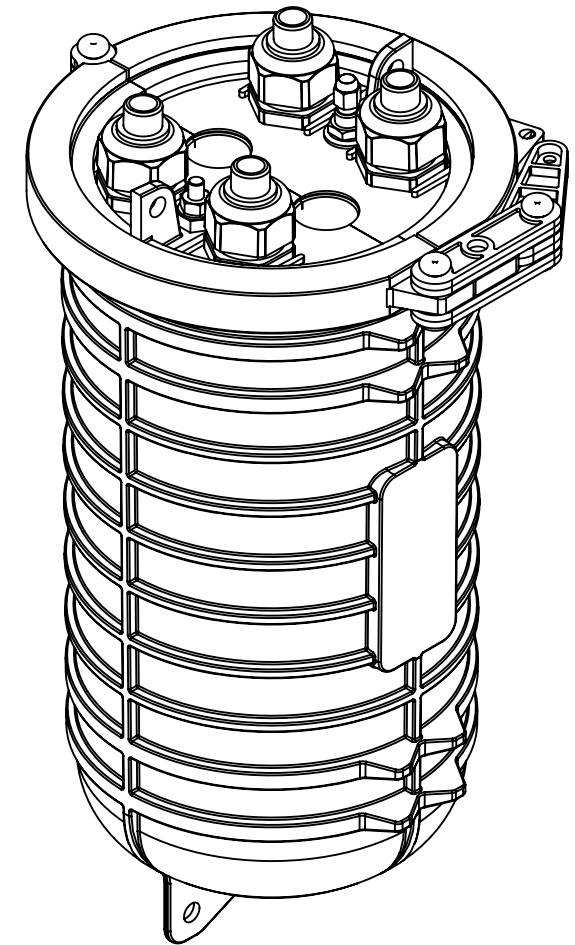
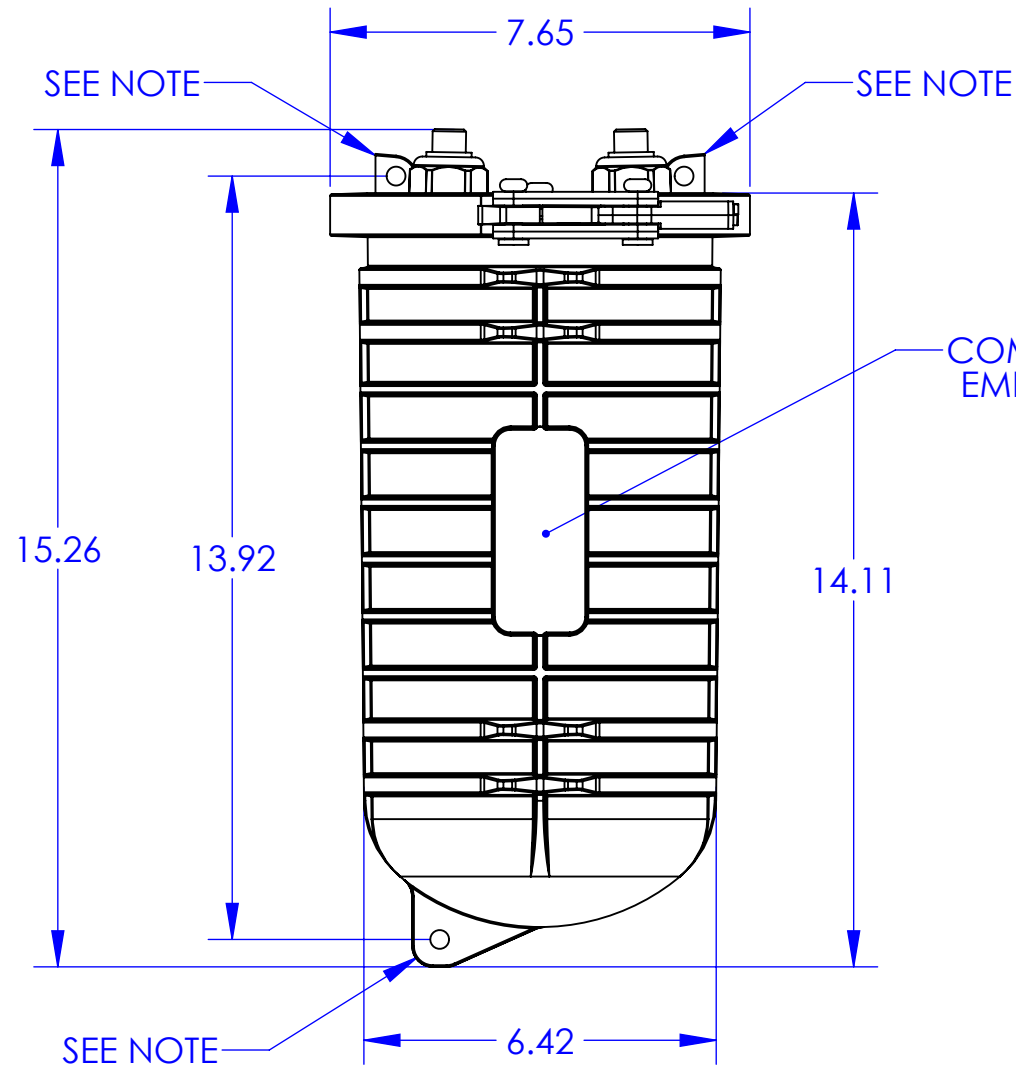
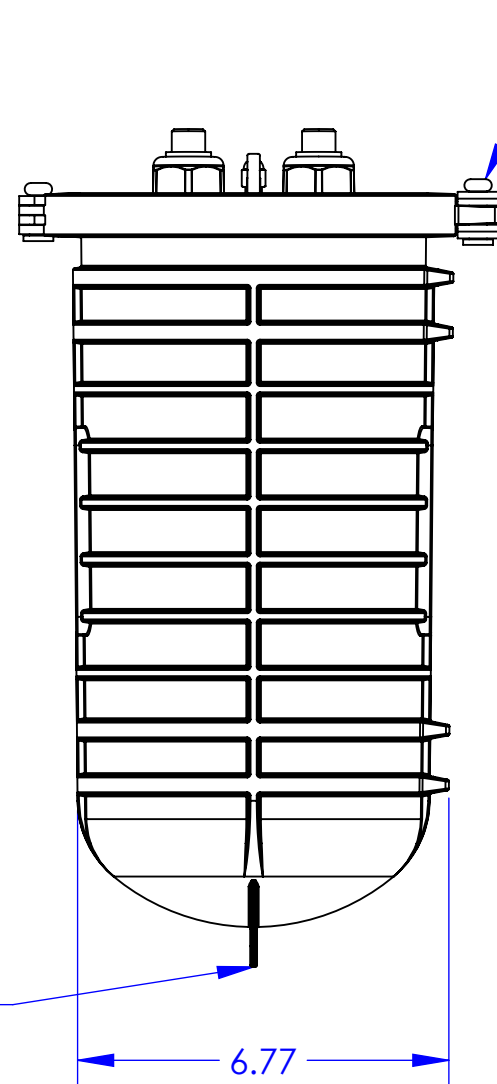

NOTE:
1. MOUNTING PROVISIONS PROVIDED FOR AERIAL HANGER BRACKETS OR WALL/POLE MOUNTING BRACKETS.

UNLESS OTHERWISE SPECIFIED DIMENSIONS ARE IN INCHES TOLERANCES ARE: FRACTIONS: ±1/32 DECIMALS: .XX=±.03 .XXX=±.010 ANGLES: ±1° ALL FLATS TO BE ±.005		THIS DOCUMENT AND THE INFORMATION CONTAINED THEREIN ARE CONFIDENTIAL & PROPRIETARY TO MULTILINK AND MAY NOT BE COPIED OR DISCLOSED TO OTHERS WITHOUT A WRITTEN CONSENT FROM MULTILINK. THE INFORMATION IS TO BE PROMPTLY RETURNED TO MULTILINK UPON REQUEST.			
NO SHARP EDGES OR BURRS ALLOWED MATERIAL: SEE B.O.M. FINISH: N/A DO NOT SCALE DRAWING		DRAWN BY: L.P.K. DATE: 07/28/2008 CHECKED: _____ DATE: _____ MFG ENG: _____ DATE: _____ QUALITY ENG: _____ DATE: _____			
SIZE: B	DWG. NO.: 020-059-10-REF	REV.: 06	SCALE: 1:3.5	CAD FILE: 020-059-10-REF	SHEET: 1 OF 2

REV.	ECN #	DESCRIPTION OF CHANGE	DATE	BY	MFG ENG
01	2383	UPDATED ITEMS 1, 2, & 3 / INITIAL RELEASE	07/28/08	L.P.K.	
02	2502	ADDED NOTE 7 / SEE SHEET 2	09/19/11	L.P.K.	
03	2653	REPLACED ITEM #2	03/27/12	L.P.K.	

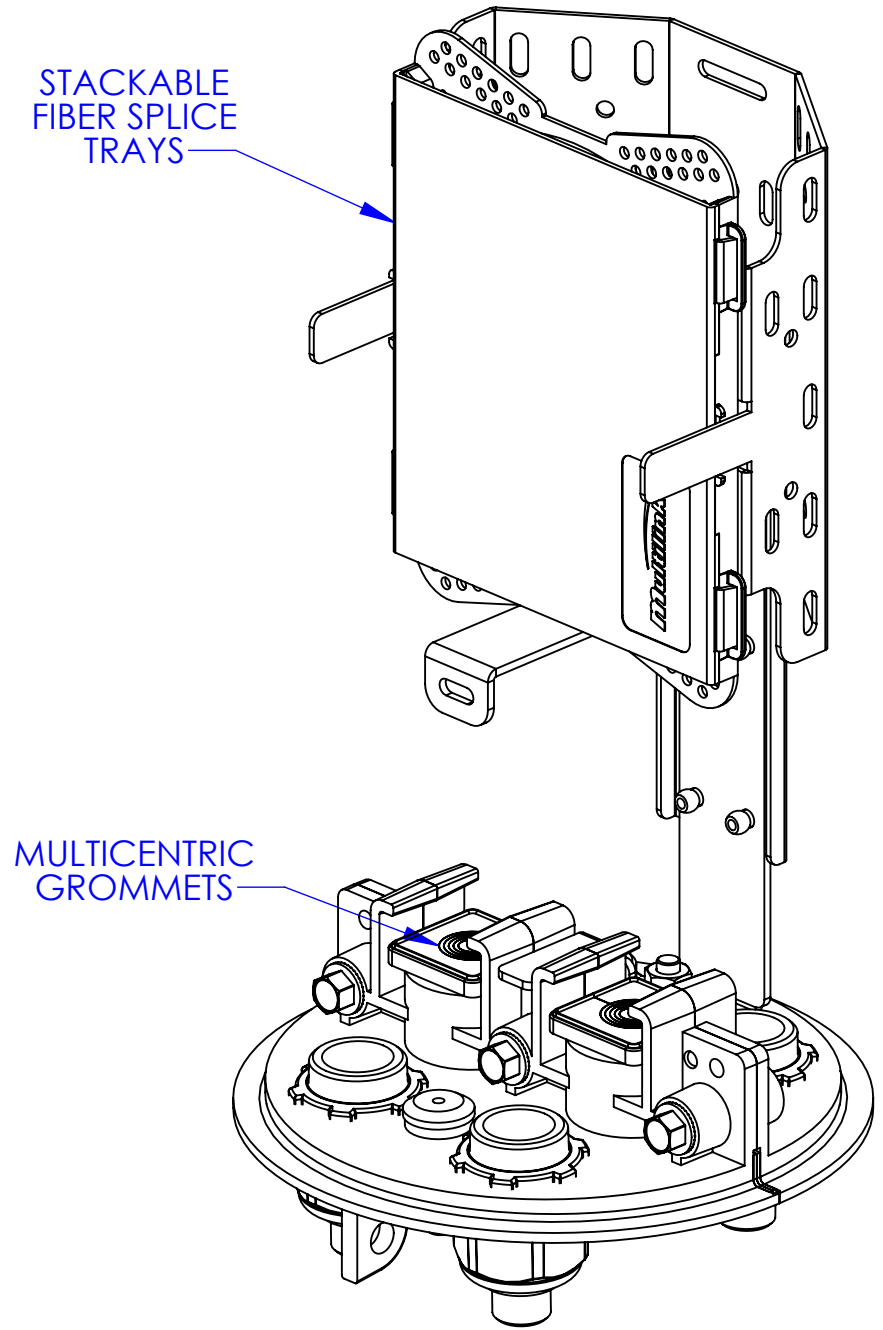
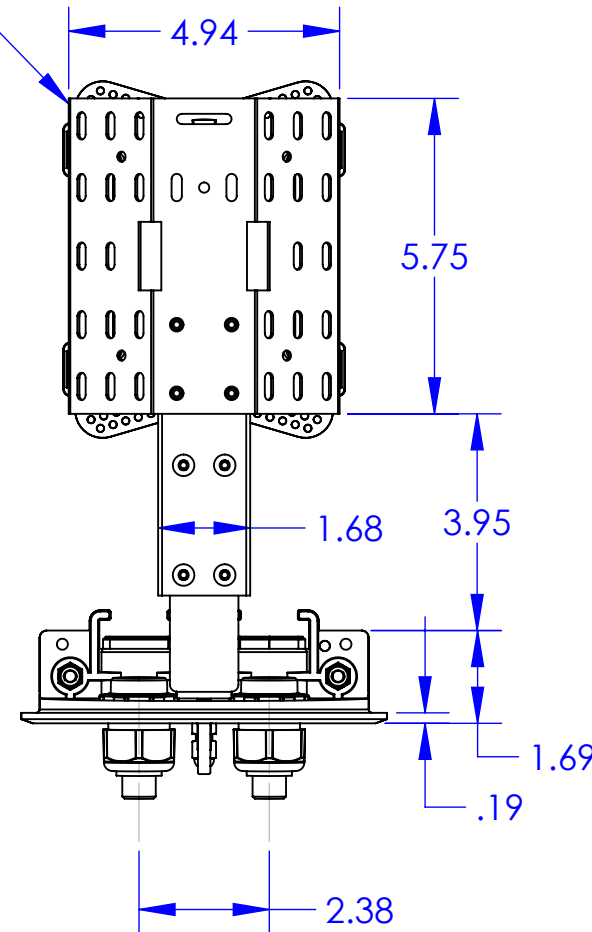
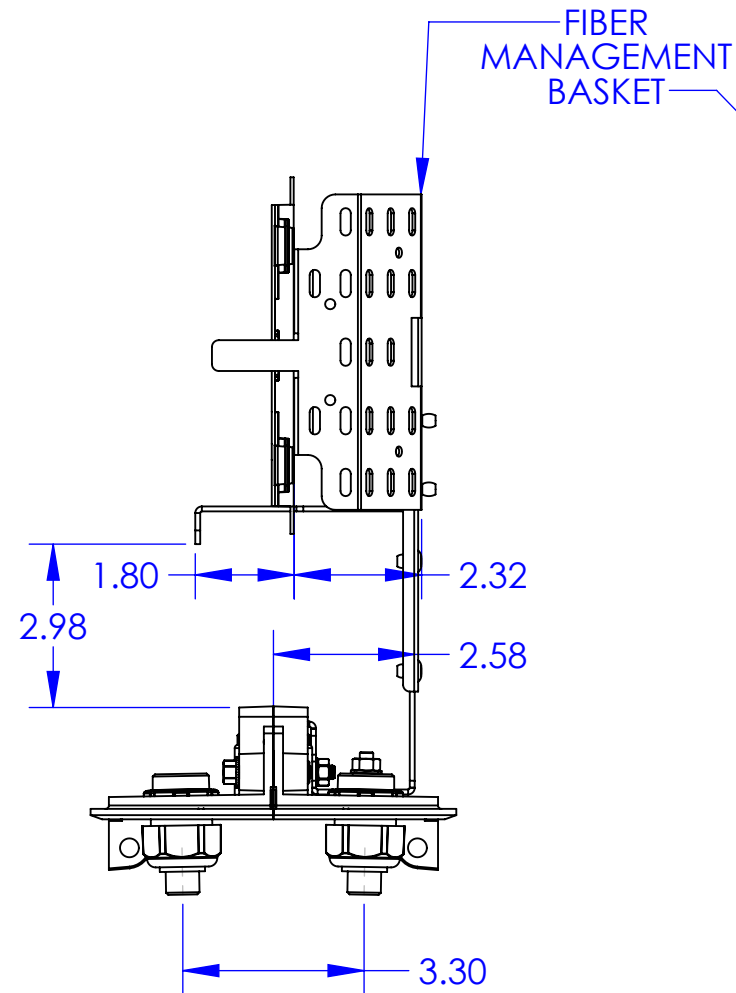
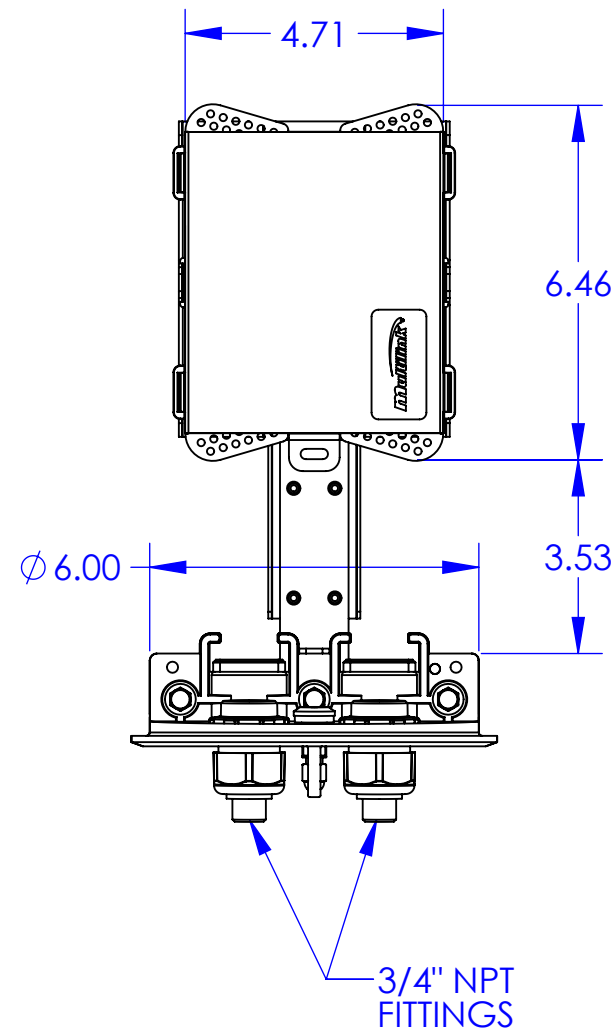
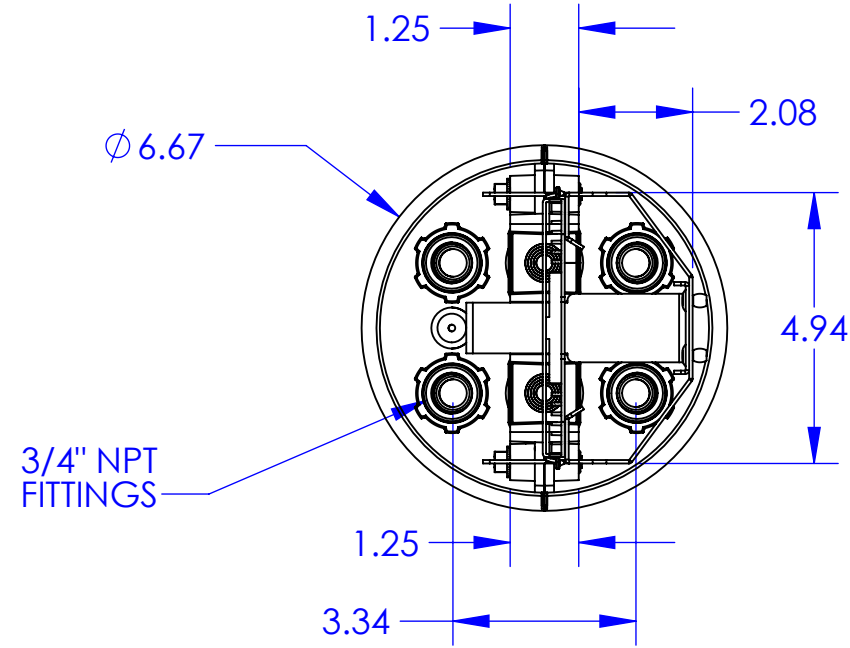

UNLESS OTHERWISE SPECIFIED DIMENSIONS ARE IN INCHES TOLERANCES ARE:
 FRACTIONS: $\pm 1/32$ DECIMALS: .XX = $\pm .03$.XXX = $\pm .010$ ANGLES: $\pm 1^\circ$
 ALL FLATS TO BE $\pm .005$
NO SHARP EDGES OR BURRS ALLOWED

MATERIAL: SEE B.O.M.
 FINISH: N/A
 DO NOT SCALE DRAWING

THIS DOCUMENT AND THE INFORMATION CONTAINED THEREIN ARE CONFIDENTIAL & PROPRIETARY TO MULTILINK AND MAY NOT BE COPIED OR DISCLOSED TO OTHERS WITHOUT A WRITTEN CONSENT FROM MULTILINK. THE INFORMATION IS TO BE PROMPTLY RETURNED TO MULTILINK UPON REQUEST.

DRAWN BY: L.P.K. DATE: 07/28/2008
 CHECKED: DATE:
 MFG ENG: DATE:
 QUALITY ENG: DATE:

Multilink

4024D SPLICE ENCL
 CRTN ASSY W/1 1120-SSTP

SIZE **B** DWG. NO. 020-059-10-REF REV. **06**
 SCALE: 1:3.5 CAD FILE: 020-059-10-REF SHEET: 2 OF 2