



Starfighter Xpress

Stock ID	Description
020-243-10	Starfighter Xpress Dual Inline FOSC
020-244-10	Starfighter Xpress 4 Port Dual Inline FOSC
020-245-10	Starfighter Xpress 8 Port Inline FOSC

Table of Contents

Visit gomultilink.com/StarfighterXpress.aspx for installation video!

General	3
1. Introduction	3
1.1 Product Description & FTTX Network Planning	
1.2 Starfighter Xpress Dimensional Drawing	
2. Preparations	5
2.1 Installation Outline	
2.2 Starfighter Xpress Checklist	
2.3 Recommended Tools and Equipment	
3. General Warnings	6
3.1 Laser Light Warning	
3.2 Laser Light Magnification Warning	
3.3 Loose Fiber Warning	
3.4 Sharp Edge Warning	
3.5 Safety Glasses Warning	
3.6 Electrical Shock Warning	
3.7 Fiber Damage Warning	
4. Installation	7
Entry Cable Preparations	7
4.1 Entry Cable Prep	
4.2 Cable Jacket Removal	
4.3 Cut & Trim CSM	
4.4 Armored Cable	
4.5 Grounding Kit <i>*sold separately</i>	
4.6 Connecting the Grounding Braid	
4.7 Secured Grounding	
4.8 Cable Anchoring	
4.9 Buffer Tube Branching	
4.10 Buffer Tube Anchoring	
4.11 Buffer Tube Prep	
4.12 Fiber Routing	
4.13 Cable Entry Grommet Inserts	
Exit Cable Preparations for Flat Drop	10
4.14 Exit Cable Jacket Removal	
4.15 Cut & Trim CSM	
4.16 Exit Cable Grommet	
4.17 Securing Exit Cabling	
4.18 Exit Cable Grommet Inserts	
4.19 Cable Anchoring & Alignment	

Continue on page 2 for the remainder of the Table of Contents.

Contact Us

North America	Europe, Middle East & Africa	Latin & South America
Tel: +1 440 366 6966	Tel: +1 440 366 6966	Tel: +1 954 499 9203
Fax: +1 440 366 6802	Fax: +1 440 366 6802	Mobile: +1 305 684 2388
Email: engsupport@gomultilink.com	Email: engsupport@gomultilink.com	Email: hquinones@gomultilink.com

Scan QR for website.



Table of Contents (Cont.)

Splicing & Field Installable Connectors	13
4.20 Splice Tray Kit <i>*sold separately</i>	
4.21 Splice Chip Installation	
4.22 Splice Tray Installation	
4.23 Buffer Tube in Prep to Splice	
4.24 Fiber Anchoring	
4.25 Routing Fiber Through the Splice Tray	
4.26 Install Field Installable Connectors	
4.27 Plugging in Field Installable Connectors to Ported Cover	
Splicing & Fiber Jumpers	15
4.28 Splice Tray Kit <i>*sold separately</i>	
4.29 Splice Chip Installation	
4.30 Splice Tray Installation	
4.31 Buffer Tube in Prep to Splice	
4.32 Fiber Anchoring	
4.33 Splice Buffer Tubes to Pigtail(s)	
4.34 Patch & Splice Options	
4.34.1 Splice Exit Drop to Pigtail(s)	
4.34.2 Install Field Installable Connectors	
4.35 Install Bulkhead Bracket & Connectors	
4.36 Plugging in Jumpers to Ported Cover	
Field Installable Connectors & Fiber Jumpers	18
4.37 Install Field Installable Connectors to Entry	
4.38 Install Field Installable Connectors to Exit	
4.39 Install Bulkhead Bracket & Connectors	
4.40 Plugging in Jumpers to Ported Cover	
Closing the Closure	19
4.41 Properly Securing Fiber	
4.42 Proper Grommet Seal	
4.43 Applying the Sealant	
4.44 Torque Tighten Hex Bolts	
Field Testing	20
4.45 Air Pressure Solution	
4.46 Applying Air into Closure	
4.47 Pressure Testing PASS	
4.48 Pressure Testing FAIL	
Mounting Options	21
4.49 Aerial Mounting	
4.50 Wall/Pole Mounting	
5. Figures & Guides	22
5.1 Fiber Figures & Diagrams	
6. Accessory List	23

Contact Us

North America	Europe, Middle East & Africa	Latin & South America
Tel: +1 440 366 6966	Tel: +1 440 366 6966	Tel: +1 954 499 9203
Fax: +1 440 366 6802	Fax: +1 440 366 6802	Mobile: +1 305 684 2388
Email: engsupport@gomultilink.com	Email: engsupport@gomultilink.com	Email: hquinones@gomultilink.com

General

This installation guide provides guidelines for preparation and installation of Multilink's Starfighter Xpress. This product provides a solution for in-line access to the fiber optic trunk line and quick connection to subscribers single drop cable or to low count drop, feeder or lateral cable to be connected to single drop cable at another location. This guide is for installers who are familiar with fiber optic cable systems and their applications.

1. Introduction

1.1 Product Description & FTTX Network Planning

Multilink's Starfighter Xpress 4 Port Dual Inline Fiber Optic Splice Closure allows a FTTX provider to access the fiber optic trunk line (that is deployed from the central office, headend, or remote hub) and branch connections off to individual subscribers (such as home, apartment, or individual business). Connections can also be branched off to low count drop cables to feed another terminal point. Contact Multilink at (440) 366-6966 for assistance for FTTX network planning and FTTX deployment products.



1.2 Starfighter Xpress Dimensional Drawing

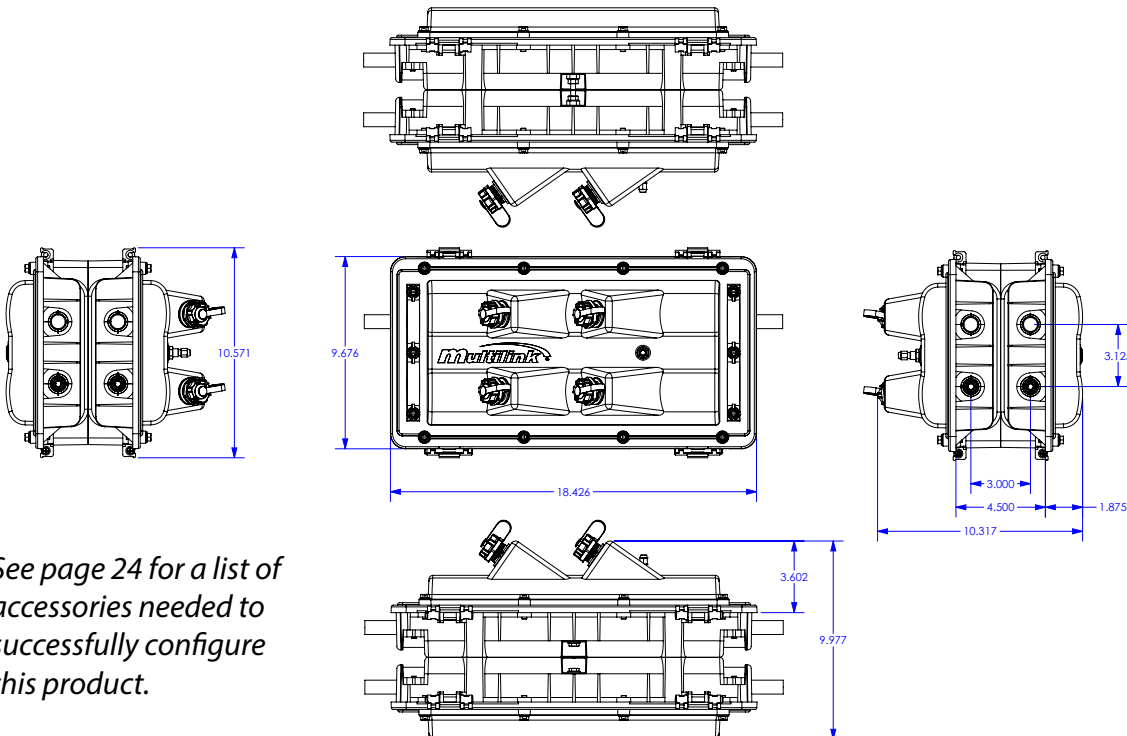

See page 24 for a list of accessories needed to successfully configure this product.

Contact Us

North America	Europe, Middle East & Africa	Latin & South America
Tel: +1 440 366 6966	Tel: +1 440 366 6966	Tel: +1 954 499 9203
Fax: +1 440 366 6802	Fax: +1 440 366 6802	Mobile: +1 305 684 2388
Email: engsupport@gomultilink.com	Email: engsupport@gomultilink.com	Email: hquinones@gomultilink.com

Introduction (Cont.)

Starfighter Xpress Dimensional Drawing (Cont.)

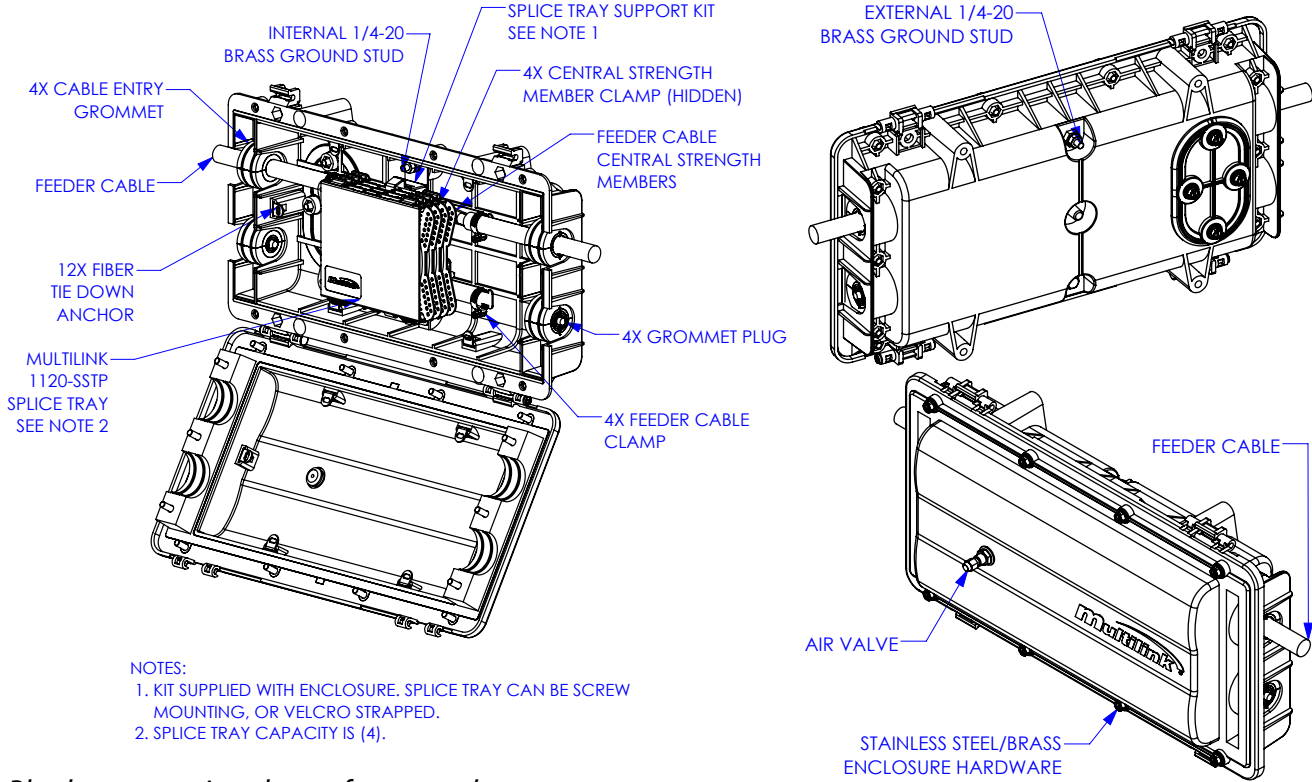

- NOTES:
1. KIT SUPPLIED WITH ENCLOSURE. SPLICE TRAY CAN BE SCREW MOUNTING, OR VELCRO STRAPPED.
 2. SPLICE TRAY CAPACITY IS (4).

Blank cover option shown for example.

See page 24 for a list of accessories needed to successfully configure this product.

Parameter	Specification
Splice Capacity	48 (splice only) 24 (patch & splice)
Patch Capacity	12 SC / 24 LC
Cable Diameter	Up to 1"
Connector Types	SC/APC SC/UPC LC/APC LC/UPC
Mating Outdoor Connector Type	Multilink Surelight NPT Compression Fitting
Cable Types	Unarmored Armored
Weight (as shipped)	N/A

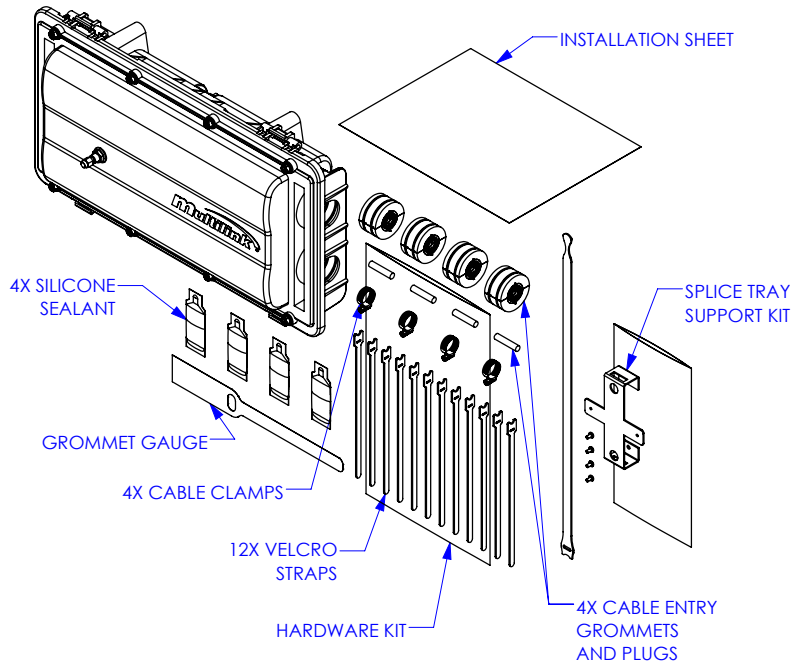

Contact Us

North America	Europe, Middle East & Africa	Latin & South America
Tel: +1 440 366 6966	Tel: +1 440 366 6966	Tel: +1 954 499 9203
Fax: +1 440 366 6802	Fax: +1 440 366 6802	Mobile: +1 305 684 2388
Email: engsupport@gomultilink.com	Email: engsupport@gomultilink.com	Email: hquinones@gomultilink.com

2. Preparations

2.1 Installation Outline

The general procedure of the Starfighter Xpress installation includes:

- Removal of cable jacketing and excess CSM
- Ring cut, fiber separation, CSM tie down, and routing fiber
- Securing cables to the Starfighter Xpress mounting bracket (included)
- Configuring grommets for cable entry and exit drop
- Splicing and fiber termination

2.2 Starfighter Xpress Checklist

Each kit includes the following items:

- 1x Starfighter Xpress Assembly (A)
- 1x Splice Tray Support Kit (B)
- 1x Hardware Kit (C)

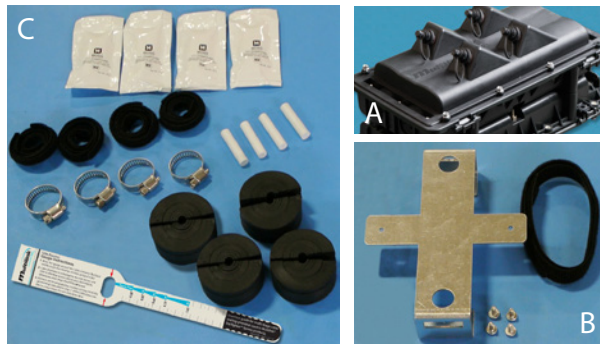

2.3 Recommended Tools and Equipment

The Following list includes tools and equipment that you may need for a successful installation (these tools **ARE NOT INCLUDED** with the product or accessories):

- Safety Glasses
- Cut-Resistant Gloves
- Hex-Head Screw Driver (1/4" head)
- Phillips Screw Driver (magnetic recommended)
- 216C Tool (3/8" & 7/16" heads)
- Scissors
- Tape Measure
- Side Cutters/Diagonal Cutters
- Pliers
- Marker
- Ring Cut Tool
- Buffer stripping Tool
- Mastic Tape
- Torque Wrench
- Air Pressure Source
- Air Pressure Gauge
- Spray Bottle
- Testing Solution

See page 24 for a list of accessories needed to successfully configure this product.

North America	Europe, Middle East & Africa	Latin & South America
Tel: +1 440 366 6966	Tel: +1 440 366 6966	Tel: +1 954 499 9203
Fax: +1 440 366 6802	Fax: +1 440 366 6802	Mobile: +1 305 684 2388
Email: engsupport@gomultilink.com	Email: engsupport@gomultilink.com	Email: hquinones@gomultilink.com

3. General Warnings

3.1 Laser Light Warning

Never look directly into the end of a fiber that may be carrying laser light. Laser light can be invisible and may be harmful to your eyes. Viewing it directly may not cause pain; therefore it will not cause blinking or the iris of the eye to close involuntarily as it does when viewing bright light. Consequently, serious damage to the retina of the eye is possible. Should accidental exposure of laser light be suspected, arrange an eye exam immediately.

3.2 Laser Light Magnification Warning

Do not use magnifiers in the presence of laser radiation. Diffused laser light can cause serious eye damage if focused with optical instruments.

3.3 Loose Fiber Warning

Cleaved or broken glass fibers are very sharp and can pierce the skin easily. Keep your work area clear of removed fiber. Do not allow pieces of fiber to stick to your clothing or fall into the work area where they can cause injury later. Use tweezers to pick up broken/cut pieces of fiber and place on a piece of tape that has been set aside for this purpose.

3.4 Sharp Edge Warning

The wearing of cut-resistant safety gloves to protect your hands from sharp cutting tools and the metal armoring of armored cable is strongly recommended. Use extreme care when working with severed armor. There may be sharp edges where the armor is damaged. Always cover the exposed/cut armor end with a wrap of black electrical tape. To minimize the chance of injury from sharp-blade tools, always cut away from yourself and others. Dispose of used blades and armor scrap properly.

3.5 Safety Glasses Warning

Use safety glasses while working is highly recommended to provide eye protection from accidental injury when handling chemicals, cables or working with fiber. Pieces of glass fiber are very sharp and have potential to damage the eye.

3.6 Electrical Shock Warning

Do not install telecommunications equipment or work with telephone wiring during a lightning storm. Telephone lines can carry high voltages from lightning causing electrical shock resulting in severe injury or death.

3.7 Fiber Damage Warning

Fiber Optic cable is highly sensitive to excessive pulling, bending and crushing. Take care when bending the cables. Be sure not to pull too hard on the fibers. Do not crush the cable or allow it to kink. Doing any of these things may cause damage to the fiber and require it to be replaced.

North America	Europe, Middle East & Africa	Latin & South America
Tel: +1 440 366 6966	Tel: +1 440 366 6966	Tel: +1 954 499 9203
Fax: +1 440 366 6802	Fax: +1 440 366 6802	Mobile: +1 305 684 2388
Email: engsupport@gomultilink.com	Email: engsupport@gomultilink.com	Email: hquinones@gomultilink.com

4. Installation

Entry Cable Preparations

Note: Fiber optic cable is sensitive to excessive pulling, bending, and crushing forces. Consult the cable specification sheet for the cable you are installing. **Do not bend the cable more sharply than the minimum recommended bend radius. Do not apply more pulling force to the cable than specified. Do not crush the cable or allow it to kink.** Doing so may cause damage that can alter the transmission characteristics of the cable; the cable may have to be replaced.

4.1 Entry Cable Prep

Measure 70" inches of cable and mark two spots on each end. Using the appropriate tool, make a ring cut at both locations (Figure 4.5A). Carefully make a horizontal cut from one circle cut to the other. During the cutting process, be sure not to damage the buffer tubes inside the cable.

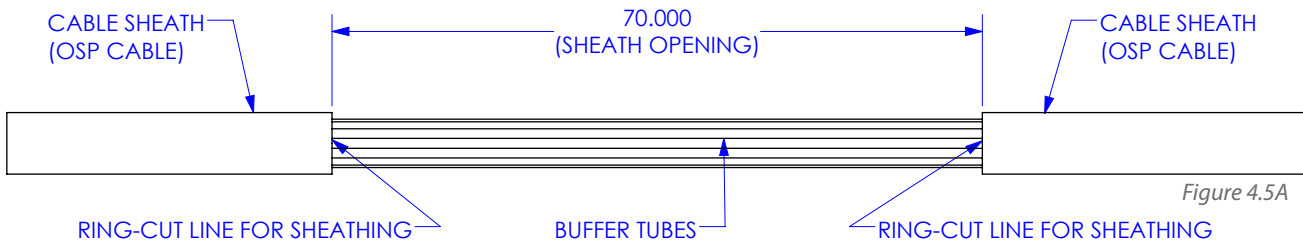
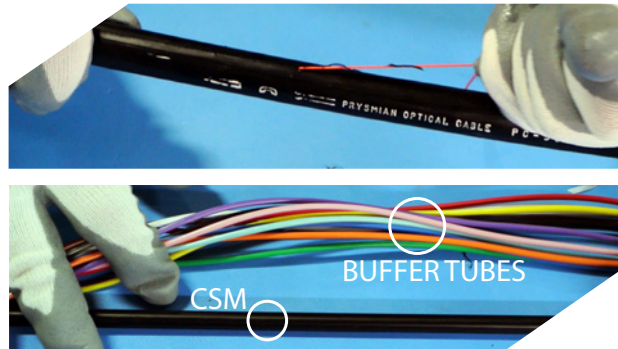

Figure 4.5A

4.2 Cable Jacket Removal

Find the rip cord in the cable and pull to help separate the jacket from the cable. Remove the outer jacket and trim away all the protective layers leaving the Central Strength Member (CSM) and buffer tubes exposed across the length of the ring cut.



4.3 Cut & Trim CSM

Measure 3" inches from each side of the ring cut locations with the exposed buffer tubes and make a mark on each side of the CSM (Figure 4.7A). Cut and trim the CSM discarding the 64" inch section (Figure 4.7B). If using armored cable continue to 4.8, else continue to 4.12.

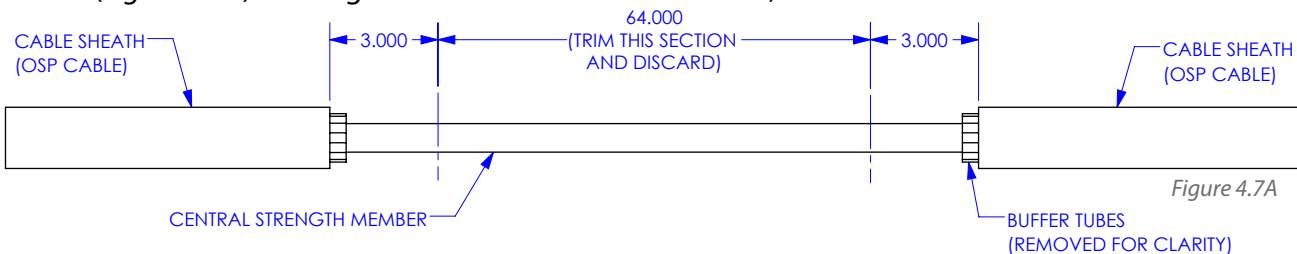

Figure 4.7A

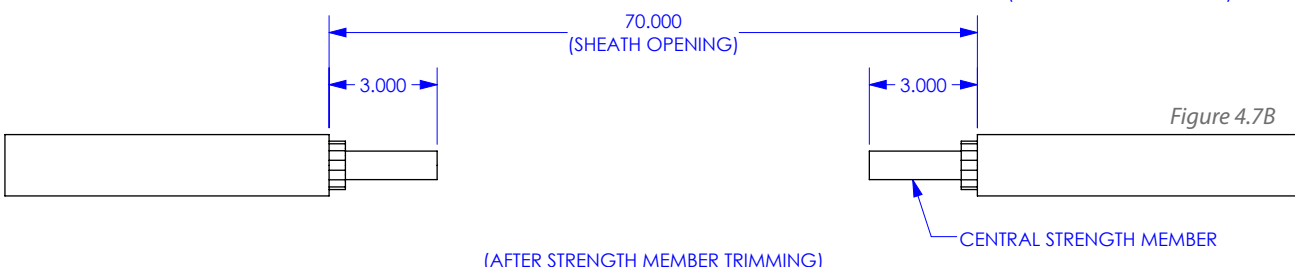
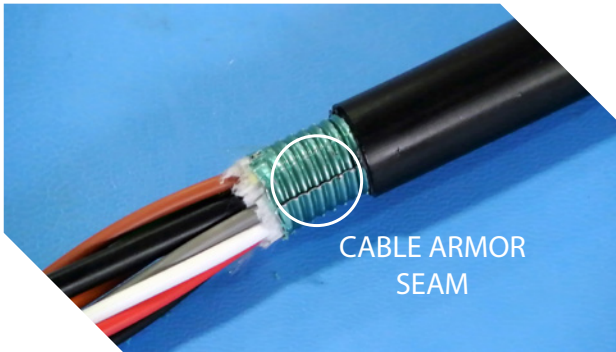

Figure 4.7B

(AFTER STRENGTH MEMBER TRIMMING)

Installation (Cont.)



4.4 Armored Cable

Allow at least 1" of the cable's armor to remain from the jacketing. Slowly peel back the armor using pliers to separate the seam to allow the wedge* (from the grounding kit, ***sold separately**) to fit between the buffer tubes and armor. Repeat on opposite side of ring cut. **See page 24 for a list of accessories needed to successfully configure this product.**

4.5 Grounding Kit **sold separately*

Allow at least 1" of the cable's armor to remain from the jacketing. Slowly peel back the armor using pliers to separate the seam to allow the wedge* (from the grounding kit, ***sold separately**) to fit between the buffer tubes and armor. Repeat on opposite side of ring cut. **See page 24 for a list of accessories needed to successfully configure this product.**

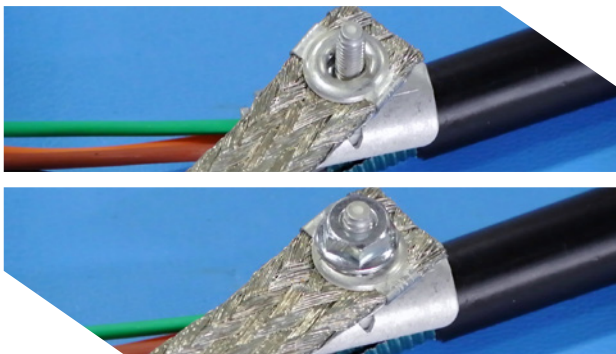
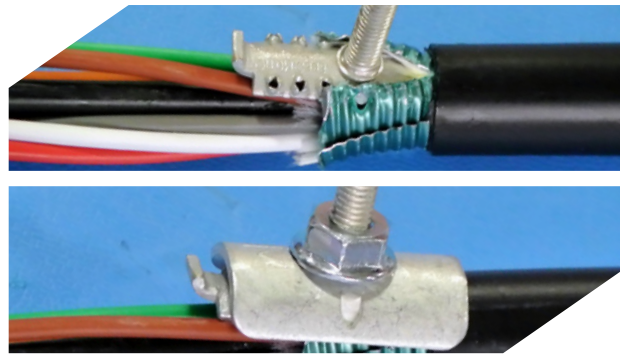

4.6 Connecting the Grounding Braid

Attach the grounding braid by using the bolt as a guide. Insert the bolt through the eyelet and using one of the supplied nuts tighten to secure the grounding braid to the armored entry cable. Repeat on opposite side of ring cut.

4.7 Secured Grounding

Loosen the ground nut on the strain relief bracket and attach the grounding braid by using the grounding bolt as a guide. Use the appropriate eyelet to allow both sides of the ring cut to be mounted in the following step. Attach the additional grounding braid using the last eyelet inserting the other end through the pass-through. Repeat the attaching process on the opposite base.

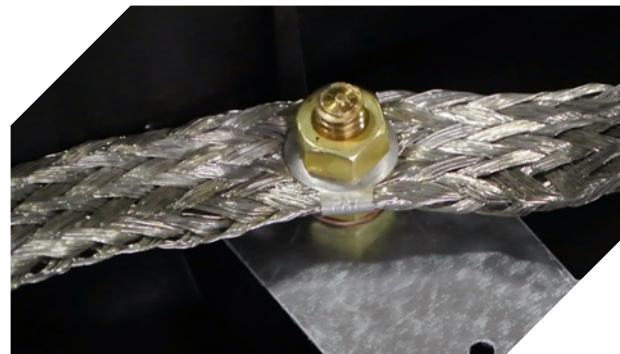

Installation (Cont.)

4.8 Cable Anchoring

On the Strain Relief Bracket located on the blank cover base, loosen the screws of CSM clamps and slide the cable's CSM under the teeth of the clamp (*Figure 4.12B*). Make sure the end of the CSM reaches the back wall of the CSM clamp (A). Tighten the screw of the clamp to secure the CSM in place. Use the hose clamps provided to secure the cable to the back end of the mounting bracket. The hose clamp should be positioned approximately $\frac{1}{4}$ " below the ring cut and inside the grooves in the Strain Relief Bracket (*Figure 4.12A*). Make sure to follow this process for both entry and exit of cable.

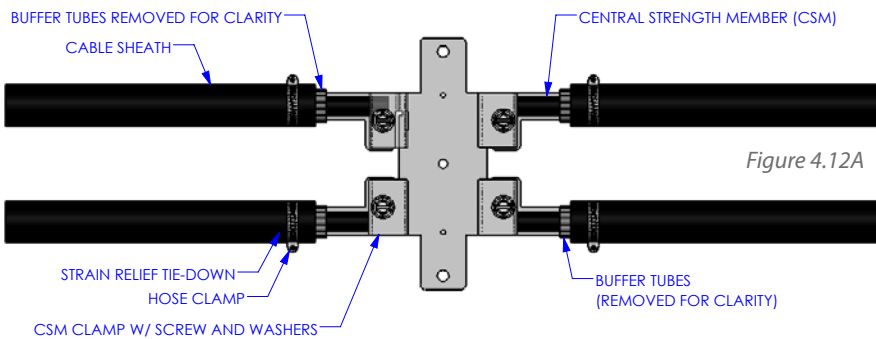
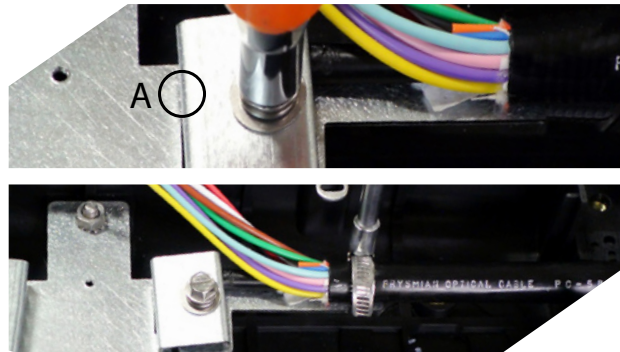

Figure 4.12A

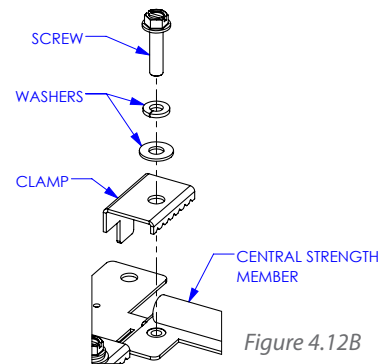
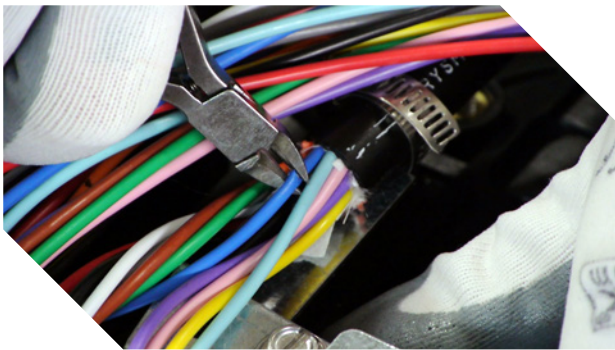

Figure 4.12B



4.9 Buffer Tube Branching

Determine the number of buffer tubes that will need to be branched off to be spliced or patched to subscriber drop off cables. Cut these selected buffer tubes on the exit side (full length of the ring cut) and separate these from the remainder buffer tubes (*Figure 5.1B*). Insert them through the pass-through into the ported cover base to be spliced at a later step.

4.10 Buffer Tube Anchoring

Insert 6 Velcro straps into the fiber management clips on the perimeter of the closure. Position the loops and loosely wrap the Velcro into rings. The Velcro will serve as cable management later, as shown.



*Buffer tubes shown for management example

Installation (Cont.)

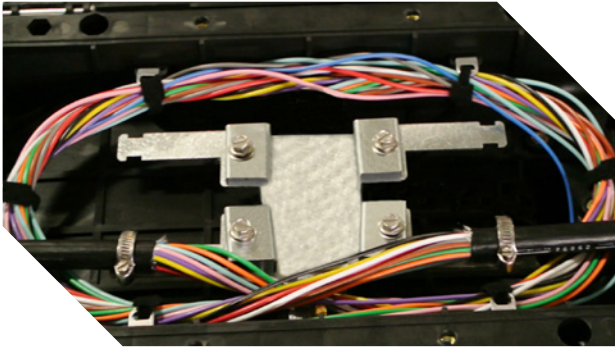

4.11 Buffer Tube Prep

Route the remainder of the pass through buffer tubes around the inside perimeter of the inside base perimeter using the Velcro straps installed in 4.14. Be sure to follow the bend radius gauge provided in *Figure 5.1A*. The ring cut length will allow these pass through buffer tubes to be managed in two loops as shown in *Figure 5.1B*.

4.12 Fiber Routing

Route and plan for at least 40" inches of fiber to be used when splicing and allow enough length to be placed into the splice tray.

4.13 Cable Entry Grommet Inserts

Measure the diameter of the cable using the provided grommet gauge. Make sure the cable is neither too big nor too small compared to the designated diameters. Use Mastic tape around the cable to build up the diameter to the next appropriate size. Once the size is determined, remove the amount of layers listed per dimension on the gauge (*Figure 4.17A*). Insert fiber jacketing into the cable entry grommet with the seam aligned vertically (*Figure 4.17B*).

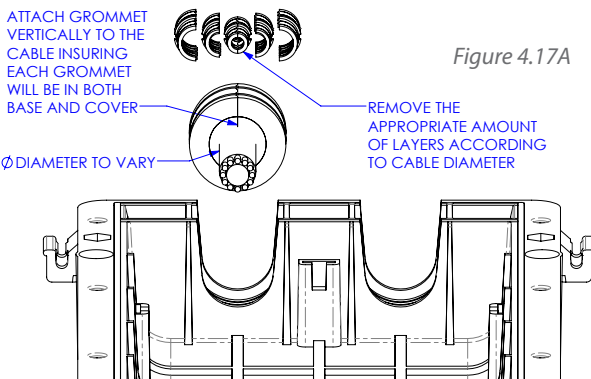

Figure 4.17A

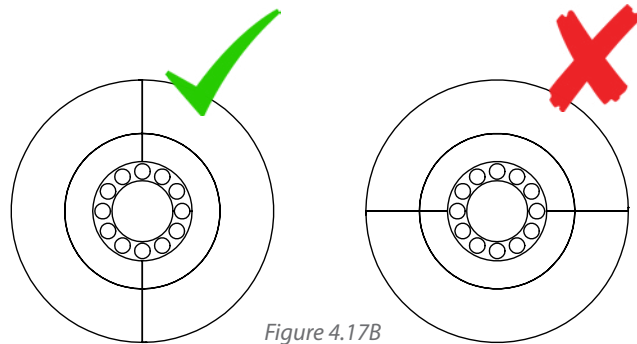
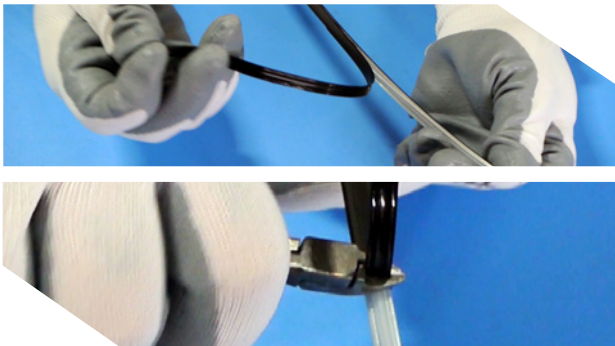

Figure 4.17B

Exit Cable Preparations for Flat Drop



4.14 Exit Cable Jacket Removal

Measure 20" inches from the end of the first exit cable and make a mark. Using the appropriate tool, strip back the outer jacketing up to the mark. Cleanly cut the jacketing to expose the CSM.

Flat drop is used in the following configuration.

Installation (Cont.)

4.15 Cut & Trim CSM

Measure 3" inches from the outside jacketing and make a mark on the CSM. Cut and discard the CSM at your second mark.

Repeat 4.18 & 4.19 for the remaining drops required for your application.

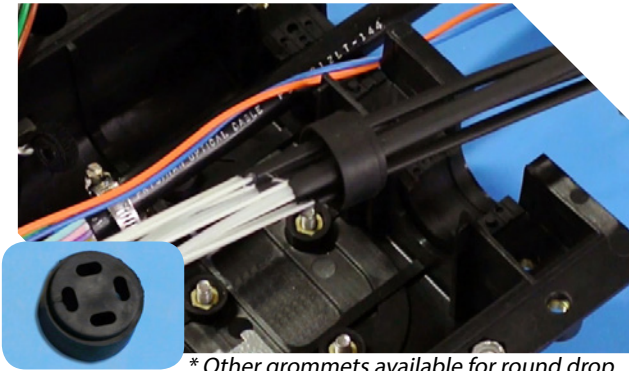
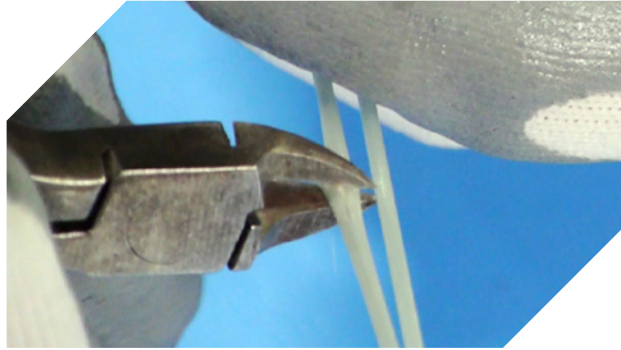

* Other grommets available for round drop

4.16 Exit Cable Grommet

On the ported cover base use the appropriate grommet for your application (determined by cable type and number of drops), insert the drop cables into it by simply feeding the end of the fiber and CSM through the holes. (If you do not use all of the holes in the grommet, utilize the grommet pins in the open holes).

4.17 Securing Exit Cabling

Gather the CSM from your drops and place them all under the teeth of the CSM clamp of the closure's Strain Relief Bracket and tighten its screw to secure them in place (Figure 4.12B).

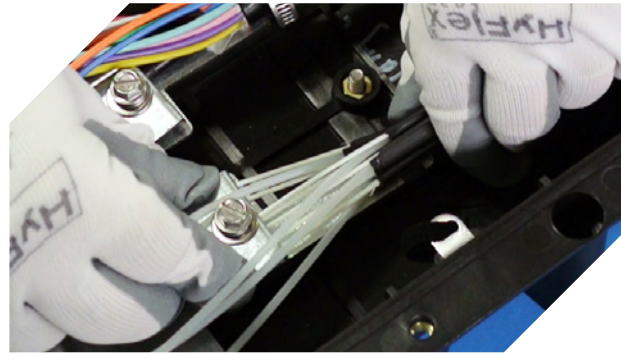

4.18 Exit Cable Grommet Inserts

Remove the appropriate layers from the grommet, in this application 3 layers of the grommet membrane (Figure 4.22A). Insert flat drop grommet into the cable entry grommet with the seam aligned vertically (Figure 4.22B).

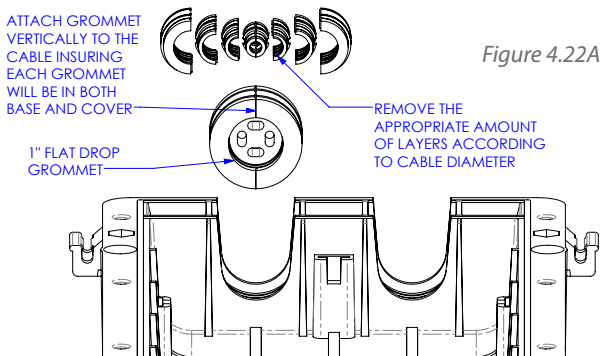

Figure 4.22A

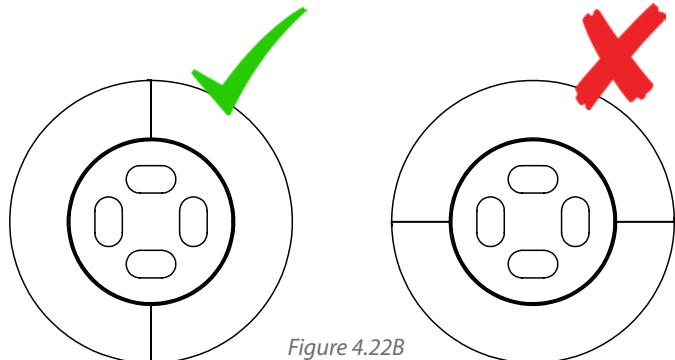
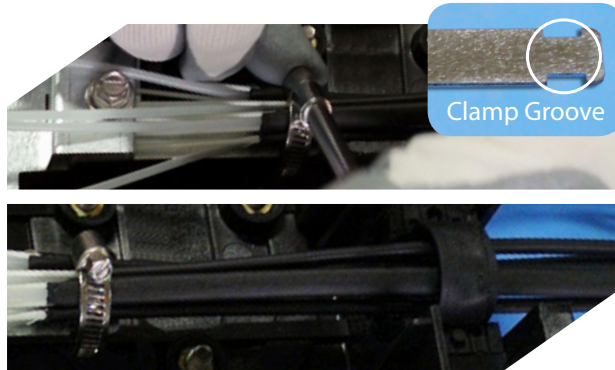

Figure 4.22B

Installation (Cont.)

4.19 Cable Anchoring & Alignment

Using the hose clamp provided, tighten the clamp in the groove of the Stain Relief Bracket until the drops are secured (*Figure 4.12A*). (Be sure to not crush the fibers while tightening the clamp.) Adjust the rubber grommet on the drops so that it aligns with the Cable Entry Grommet in the exit port.



Typically there are 3 ways to transition to the subscriber drop cables inside the Starfighter Xpress: splicing & field installable connectors, splicing & fiber jumpers and field installable connectors & fiber jumpers. **See page 24 for a list of accessories needed to successfully configure this product.**

1. For direct splicing the 250µm buffer tubes to the drop cable(s) and installing field installable connectors to the 900µm buffer tubes to plug into the ported cover continue to 4.24.

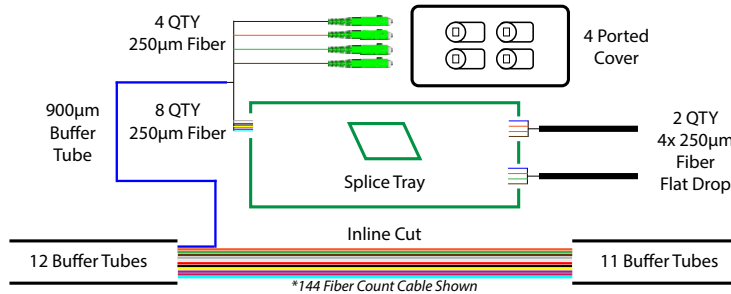

2. For splicing 250µm buffer tubes to pigtails, and either splicing the drop cable to a pigtail or patching by applying a field installable connectors onto the drop cable to be plugged into the bulkhead bracket along with plugging in fiber jumpers to the bulkhead bracket and ported cover continue to 4.32.

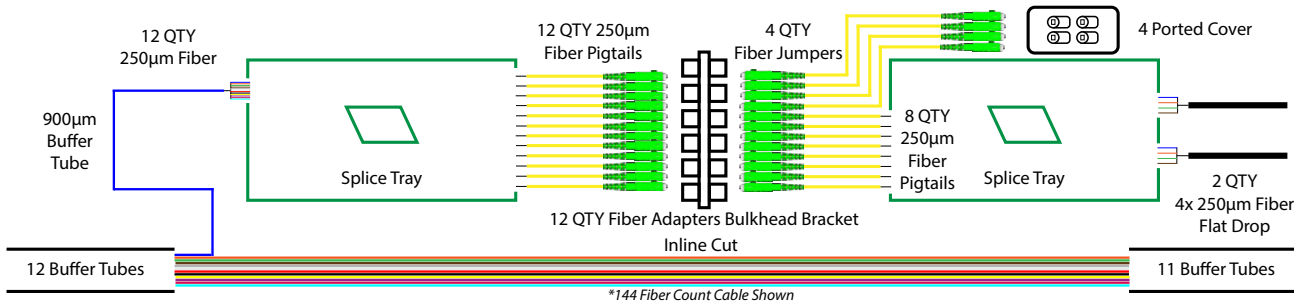

3. For patching install a field installable connector to each entry 250µm buffer tube(s) and drop cable(s) to plug into the bulkhead bracket along with plugging in the fiber jumpers to the bulkhead bracket and ported cover continue to 4.41.

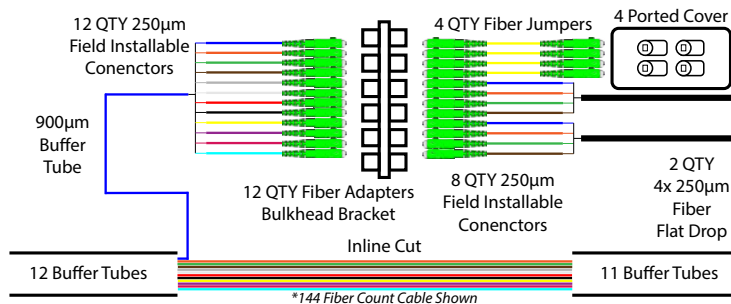

Installation (Cont.)

Splicing & Field Installable Connectors

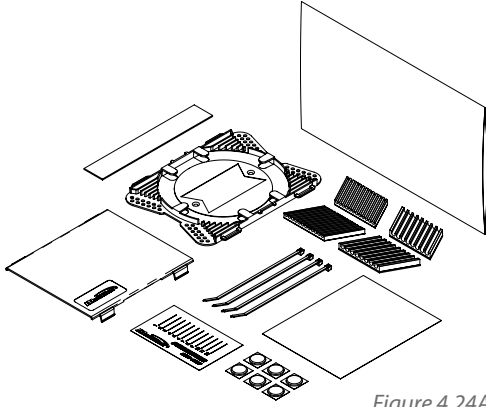

Figure 4.24A

4.20 Splice Tray Kit **sold separately*

Carefully cut open the poly bag that contains the 1120-SSTP Splice Tray Kit and remove splice tray and components (Figure 4.24A). Open the cover of splice tray by pushing the two tabs on the side of the splice tray. **See page 24 for a list of accessories needed to successfully configure this product.**

4.21 Splice Chip Installation

Select the appropriate splice chip out of the opened kit and remove the protective covering on the back, revealing the self-adhesive membrane. Place the chip in the center of the tray in the appropriate orientation for your application.

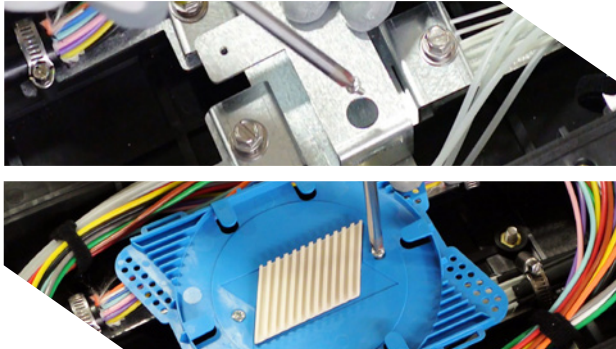
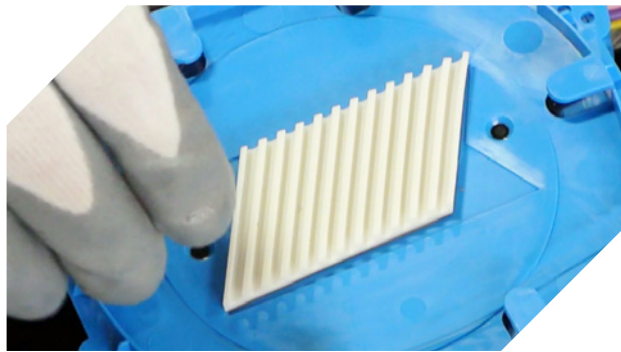

* Picture shown without splices for clarity

4.22 Splice Tray Installation

Open the Splice Tray Support Kit (Figure 2.2B) and remove its contents. Using two of the four screws supplied in the kit, secure the bracket from the kit to the Strain Relief Bracket on the ported cover base (recommended use of a magnetic Phillips screw driver). Remove the cover from the splice tray then using the other two screws secure the splice tray to the bracket after splicing is complete at a later step when appropriate.

4.23 Buffer Tube in Prep to Splice

Prepare to splice the 250µm from the buffer tubes (separated from the main line in 4.13) to 250µm from the subscriber drop cable (shown in 4.18 through 4.23). Take the strip of self-adhesive Velcro and trim it into ¼" strips with a pair of scissors. Wrap the strips around the buffer tubes to add a layer of protection. Trim excess Velcro.

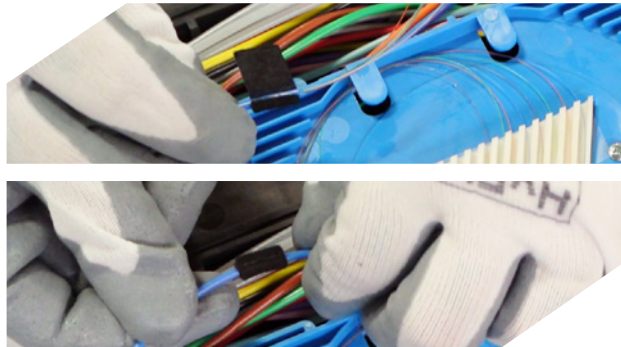

* Picture shown without splices for clarity

Installation (Cont.)

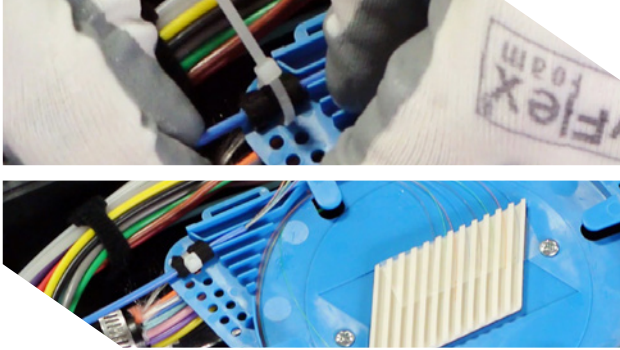

* Picture shown without splices for clarity

4.25 Routing Fiber Through the Splice Tray

Carefully route 8 250 μ m fibers in 2 full loops inside the splice tray before splicing. Take the 4 remaining 250 μ m fibers and complete 1 full loop before passing through the opposite side of the splice tray. Once finished attach splice tray cover to splice tray inserting each tab.



4.27 Plugging in Field Installable Connectors to Ported Cover

Take each Field Installable Connector and carefully route the furcation tubing from the base to the cover. Make sure when passing over the hinge the fiber tubing is not loose or a pinch in the fiber may occur when closing the cover. Continue to step 4.45.

4.24 Fiber Anchoring

Once wrapped, place the fibers into the corresponding grooves on the appropriate side and line up the Velcro on the buffer tubes with the holes on the edge of the splice tray. Insert a cable-tie from the splice tray kit into a hole near the fiber from the top then pull it back up from the bottom. Secure the cable-tie around the buffer tube and trim off excess tie with side cutters. (The cable-ties can sometimes be difficult to manage, you can pre-route the cable-ties prior to running the buffer tubes to the splice tray.) Repeat on each entry/exit buffer tubes.

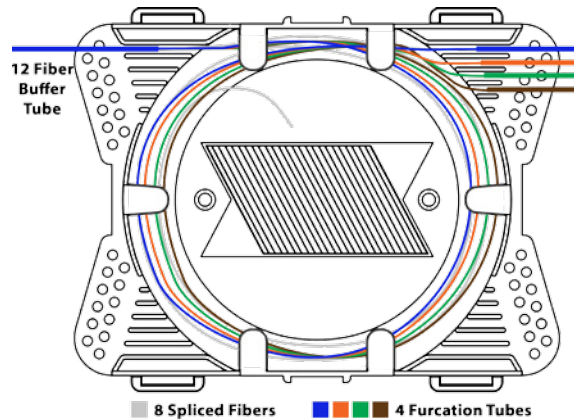

4.26 Install Field Installable Connectors

Install the appropriate colored furcation tubing on each 250 μ m fiber. On each of the 4 open 250 μ m fibers being passed through the splice tray install a field installable connector to be inserted into each ported cover entry. Be sure to secure each furcation tube to the splice tray using Velcro and cable-ties as seen in 4.28. **See page 24 for a list of accessories needed to successfully configure this product.**

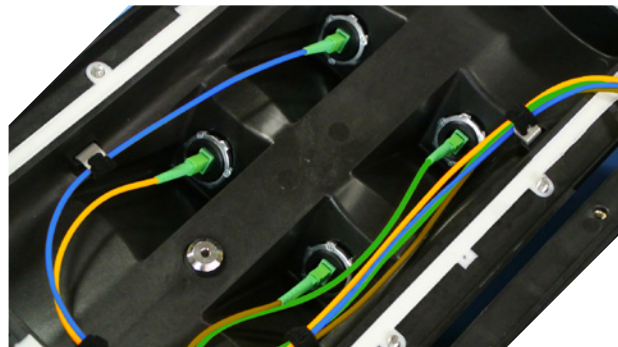

Installation (Cont.)

Splicing & Fiber Jumpers

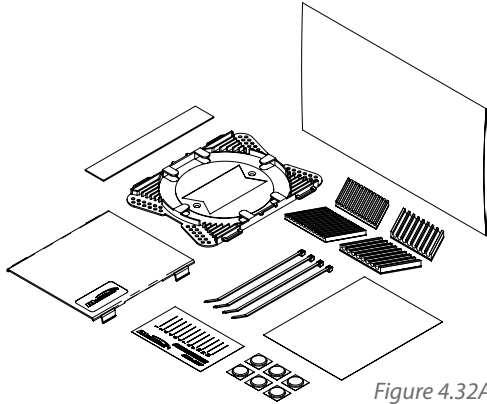

Figure 4.32A

4.28 Splice Tray Kit **sold separately*

Carefully cut open the poly bag that contains the 1120-SSTP Splice Tray Kit and remove splice tray and components (Figure 4.32A). Open the cover of splice tray by pushing the two tabs on the side of the splice tray. **See page 24 for a list of accessories needed to successfully configure this product.**

4.29 Splice Chip Installation

Select the appropriate splice chip out of the opened kit and remove the protective covering on the back, revealing the self-adhesive membrane. Place the chip in the center of the tray in the appropriate orientation for your application.

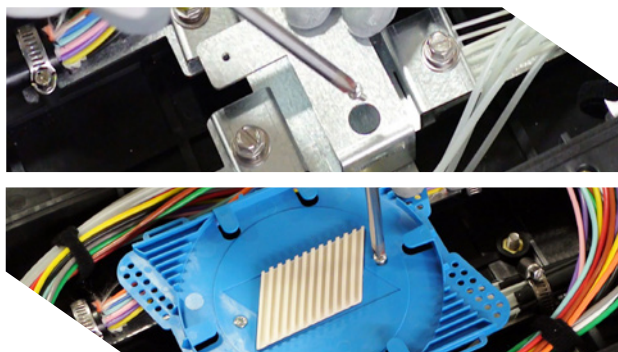
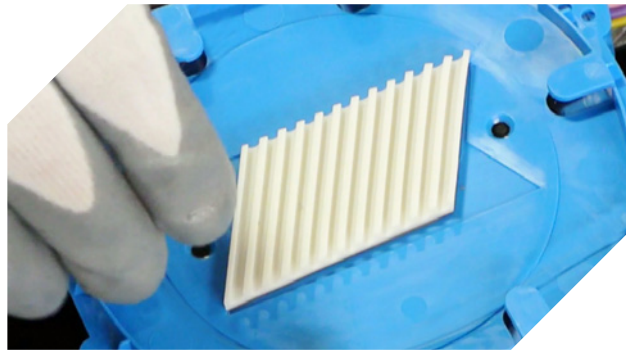

* Picture shown without splices for clarity

4.30 Splice Tray Installation

Open the Splice Tray Support Kit (Figure 2.2B) and remove its contents. Using two of the four screws supplied in the kit, secure the bracket from the kit to the Strain Relief Bracket on the ported cover base (recommended use of a magnetic Phillips screw driver). Remove the cover from the splice tray then using the other two screws secure the splice tray to the bracket after splicing is complete at a later step when appropriate.

4.31 Buffer Tube in Prep to Splice

Take the strip of self-adhesive Velcro and trim it into ¼" strips with a pair of scissors. Wrap the strips around the buffer tubes to add a layer of protection. Trim excess Velcro.



* Picture shown without splices for clarity

Installation (Cont.)

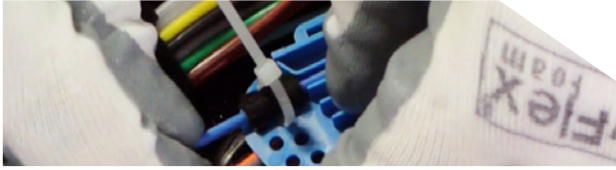

* Picture shown without splices for clarity

4.32 Fiber Anchoring

Once wrapped, place the fibers into the corresponding grooves on the appropriate side and line up the Velcro on the buffer tubes with the holes on the edge of the splice tray. Insert a cable-tie from the splice tray kit into a hole near the fiber from the top then pull it back up from the bottom. Secure the cable-tie around the buffer tube and trim off excess tie with side cutters. (The cable-ties can sometimes be difficult to manage, you can pre-route the cable-ties prior to running the buffer tubes to the splice tray.) Repeat on each entry/exit buffer tubes. Once finished attach splice tray cover to splice tray inserting each tab.

4.33 Splice Buffer Tubes to Pigtail(s)

Prepare to splice the 250 μ m from the buffer tubes (separated from the main line in 4.13) to the connectorized pigtail to be inserted into the bulkhead bracket. **See page 24 for a list of accessories needed to successfully configure this product.**

For splicing drop cable to pigtails continue to 4.38.1, otherwise continue to 4.38.2 for installing field installable connectors to the drop cable.

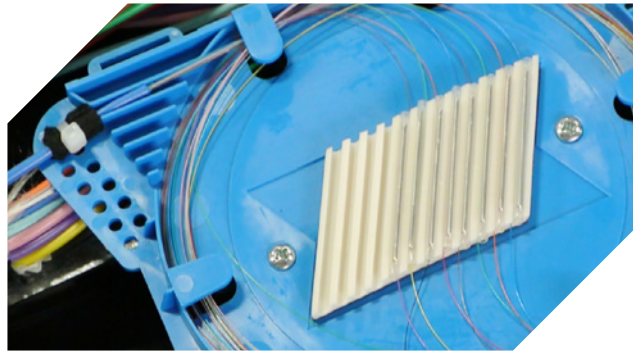

4.34.1 Splice Exit Drop to Pigtail(s)

Prepare to splice the 250 μ m from the drop cables (installed in 4.18 through 4.23) to the connectorized pigtail to be inserted into the bulkhead bracket. **See page 24 for a list of accessories needed to successfully configure this product.** Continue to step 4.39.

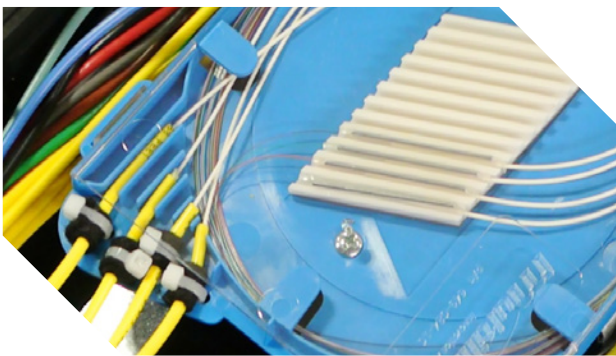

4.34.2 Install Field Installable Connectors

On each of the drop cables (installed in 4.18 through 4.23) install a field installable connector onto each drop cable end to be inserted into the bulkhead bracket. **See page 24 for a list of accessories needed to successfully configure this product.**



Installation (Cont.)

4.35 Install Bulkhead Bracket & Connectors

Before installing the bulkhead bracket make sure all fiber splices are complete and splice tray cover(s) are attached. Attach the bulkhead bracket to the internal mounting bracket (see Figure 4.39A & Figure 4.39B for detailed installation). Plug in the connectors from the pigtail(s) and/or field installable connectors to the bulkhead bracket on each appropriate side. **See page 24 for a list of accessories needed to successfully configure this product.**

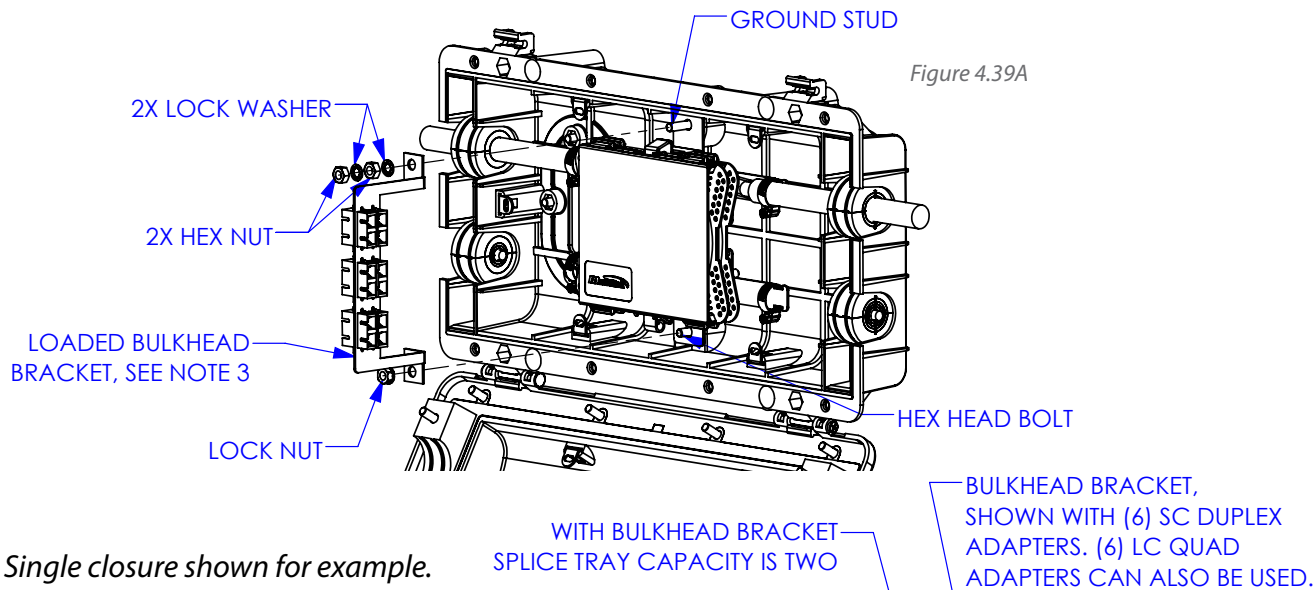

Single closure shown for example.

BULKHEAD BRACKET ASSEMBLY NOTES:

- A. REMOVE HEX NUTS, LOCK WASHERS, AND LOCK NUT FROM GROUND STUD AND HEX HEAD BOLT.
- B. PUT BULKHEAD BRACKET IN PLACE OVER STUD AND BOLT AS SHOWN.
- C. REPLACE HEX NUTS, LOCK WASHERS, AND LOCK NUT IN ORDER SHOWN.

Figure 4.39B

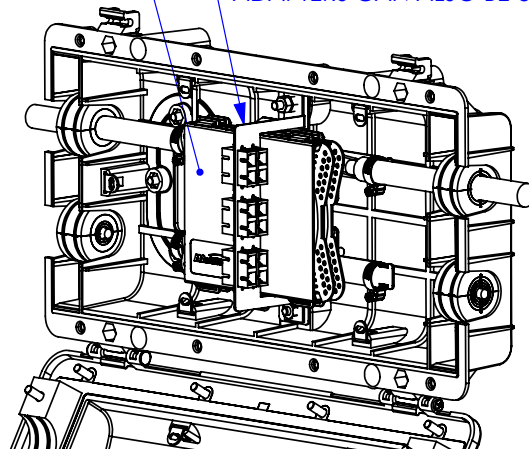

4.36 Plugging in Jumpers to Ported Cover

Take each of the four jumpers and plug each one into the 4 adapter openings in the bulkhead bracket. Carefully route the fiber of each jumper from the base to the cover. Make sure when passing over the hinge the fiber tubing is not loose or a pinch in the fiber may occur when closing the cover. Continue to step 4.45.



Installation (Cont.)

Field Installable Connectors & Fiber Jumpers

4.37 Install Field Installable Connectors to Entry

On each of the 250µm from the buffer tubes (separated from the main line in 4.13) install a field installable connector on the preferred number of fibers to be inserted into the bulkhead bracket.

See page 24 for a list of accessories needed to successfully configure this product.



* SC/APC shown as an example

4.38 Install Field Installable Connectors to Exit

On each of the drop cables (installed in 4.18 through 4.23) install a field installable connector onto each drop cable end to be inserted into the bulkhead bracket. **See page 24 for a list of accessories needed to successfully configure this product.**

4.39 Install Bulkhead Bracket & Connectors

Before installing the bulkhead bracket on the ported cover base make sure all fiber splices are complete and splice tray cover(s) are attached. Attach the bulkhead bracket to the internal mounting bracket (Figure 4.39A & Figure 4.39B). Plug in the field installable connectors from the pigtail(s) to the bulkhead bracket on each appropriate side. **See page 24 for a list of accessories needed to successfully configure this product.**

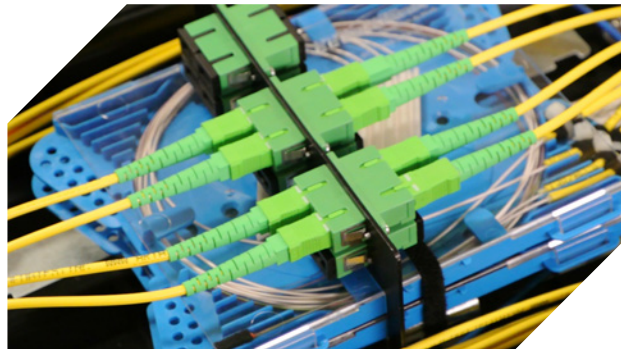

4.40 Plugging in Jumpers to Ported Cover

Take each of the four jumpers and plug each one into the 4 adapter openings in the bulkhead bracket. Carefully route the fiber of each jumper from the base to the cover. Make sure when passing over the hinge the fiber tubing is not loose or a pinch in the fiber may occur when closing the cover.

Installation (Cont.)

Closing the Closure

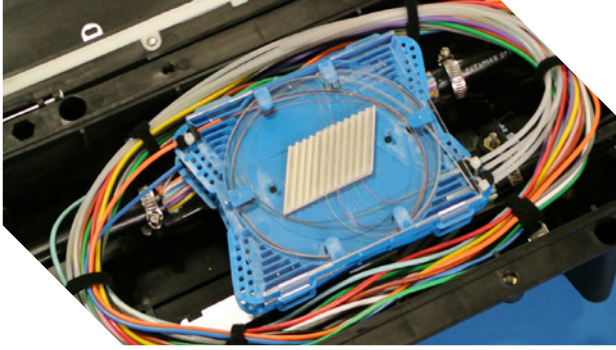

4.41 Properly Securing Fiber

Once everything has been successfully terminated and secured into place make sure all fibers are tucked away neatly with the supplied Velcro straps so as to not allow them to get pinched in closing the closure on both sides.

4.42 Proper Grommet Seal

Make sure each fiber jacketing/entry grommet has the appropriate amount of layers removed and/or mastic tape applied to accommodate the diameter being used on each base. Any grommets not being used **MUST** have a supplied pin inserted to ensure a water-tight seal.

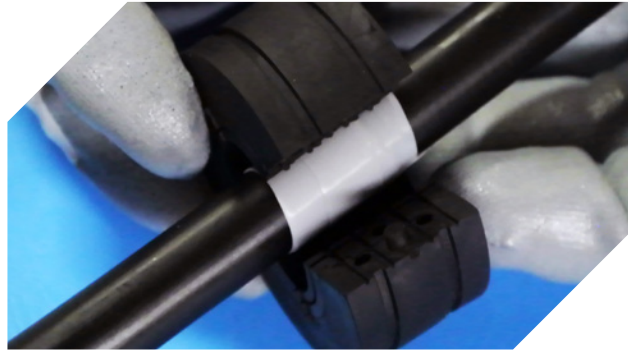

4.43 Applying the Sealant

Take a silicon sealant packet provided with the closure and slowly apply sealant to the perimeter of the closure's grommet on both the base and cover of each side. Be sure to also apply the sealant to the inside and outside of the cable entry grommet before inserting into each closure's base with the seam aligned vertically. Cover the entire outside face of the cable entry grommet once inserted into the bases creating a seal. **NOTE: Apply new sealant when reopening closure to ensure proper seal.**

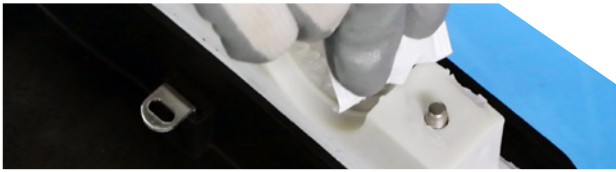

4.44 Torque Tighten Hex Bolts

Close the cover to the closure ensuring the cover gasket fits firmly into the base on both sides. Hand tighten each hex bolt on the closure's cover using the 216C tool. Now use the torque wrench set to 50 lbs/square inch and tighten following the sequence in Figure 4.48A on both sides of the closure. Once fully tightened inspect the perimeter of each closure and grommets that they are fully secured.

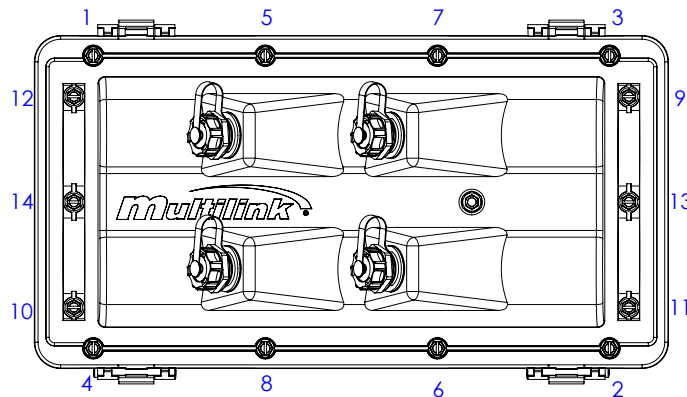

Figure 4.48A

Installation (Cont.)

Field Testing



4.45 Air Pressure Solution

Create your solution using clean water and soap inside a spray bottle. Mix well to ensure that bubbles will form upon leak. Spray the entire perimeter of each closure, around each hex bolt tighten on the cover, air valve, and ports.

4.46 Applying Air into Closure

Using the air valve on either cover as a testing entry point remove the air valve cap and apply 4 PSI of air pressure into the closure. Check using a pressure gauge to ensure the mentioned PSI was successfully inserted. **NOTE: If you insert over the recommended PSI you are at risk of compromising the integrity of the seal.** If the closure shows signs of bubbles in the solution skip to 4.52 otherwise continue to 4.51.



4.47 Pressure Testing PASS

Success! Your closure is air tight. Using your air gauge remove the excess air, attach the air valve cap and clean the solution off the closure. Continue to 4.53 & 4.54 for mounting options and finalizing your Starfighter Xpress installation.

4.48 Pressure Testing FAIL



If your closure showed any evidence of having a leak within the solution sprayed, untighten all the hex bolts on the cover and return to 4.45 and follow each step carefully to ensure a proper seal.

MULTILINK IS NOT RESPONSIBLE IF PROPER ACTION IS NOT TAKEN TO ENSURE THAT THE CLOSURE IS SEALED. TESTING IS REQUIRED UPON EACH OPENING OF THE CLOSURE. DO NOT INSTALL IF THE CLOSURE IS SHOWING ANY SIGNS OF LEAKING.

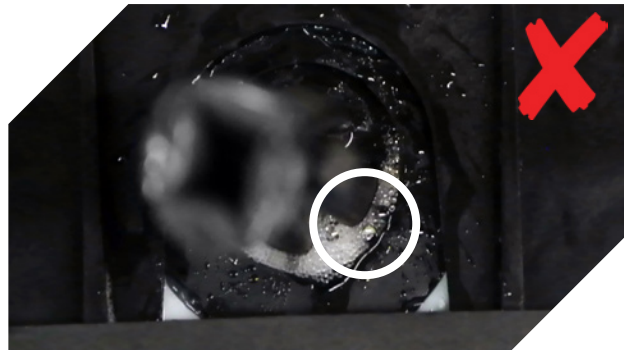

Installation (Cont.)

Mounting Options

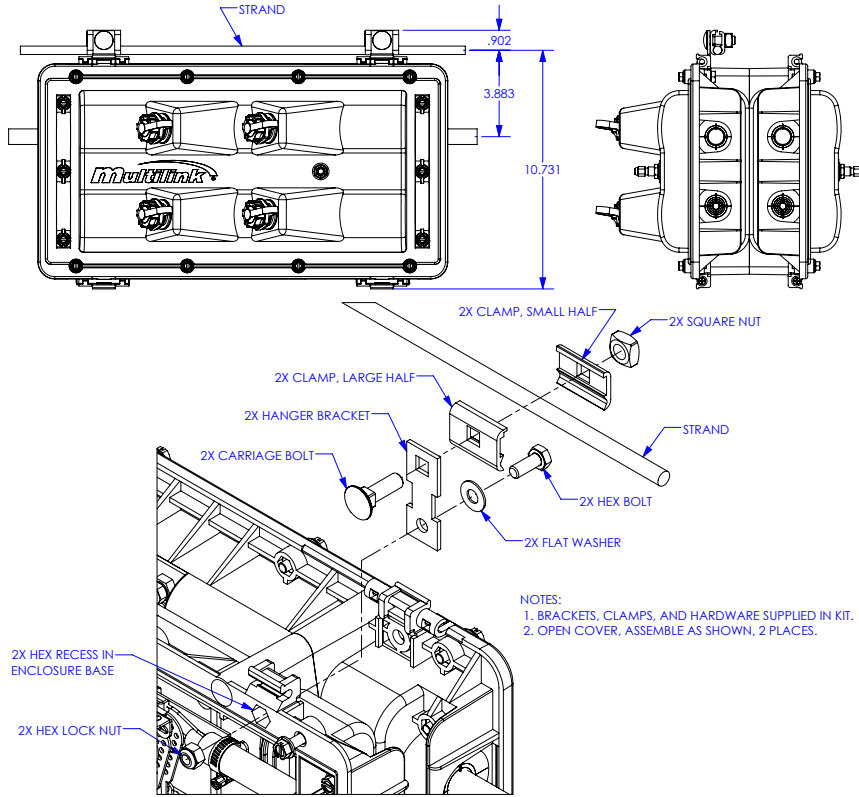

4.49 Aerial Mounting

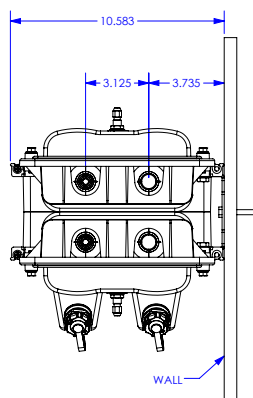
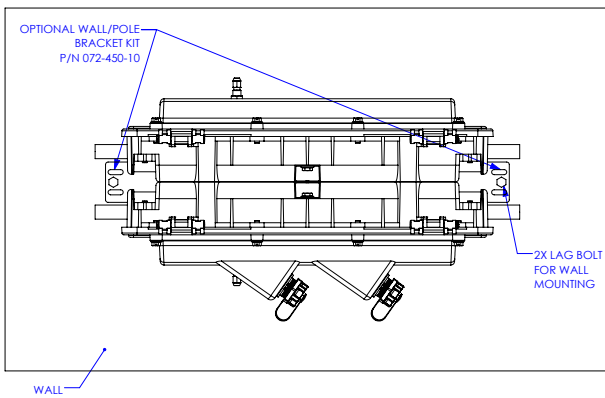
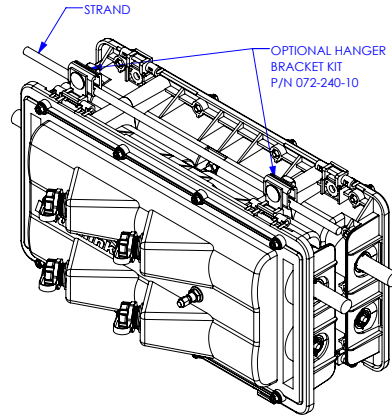

4.50 Wall/Pole Mounting

- NOTES:
 1. BRACKETS AND ASSEMBLY HARDWARE SUPPLIED IN KIT FOR WALL OR POLE MOUNTING.
 2. STRAPS AND/OR LAG BOLTS CUSTOMER SUPPLIED. STRAPS FOR ANY POLE TYPE, LAG BOLTS FOR WOODEN POLE OR WALL MOUNT.
 3. OPEN COVERS, ASSEMBLE AS SHOWN, BOTH ENDS.

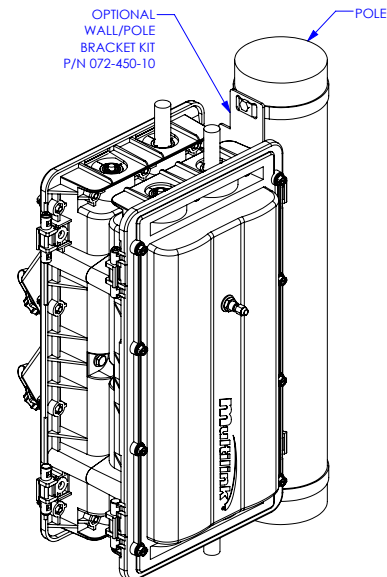
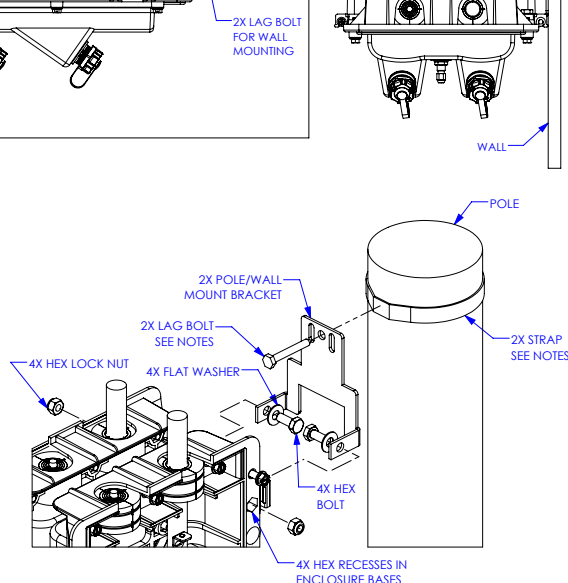

5. Figures & Guides

5.1 Fiber Figures & Diagrams

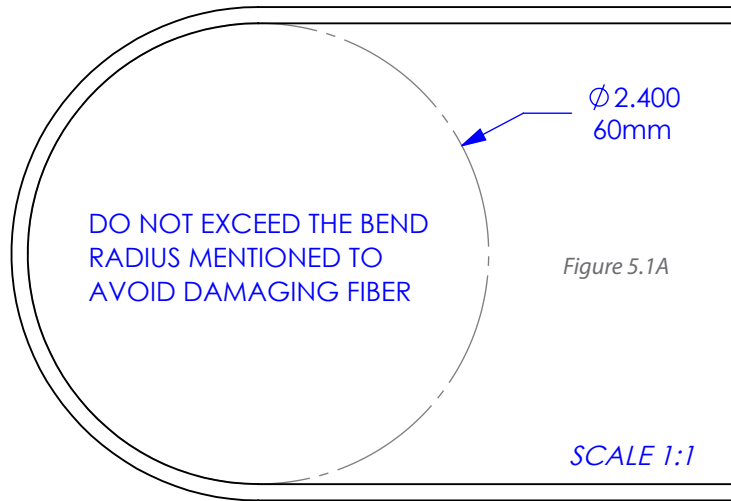

BEND RADIUS GAUGE

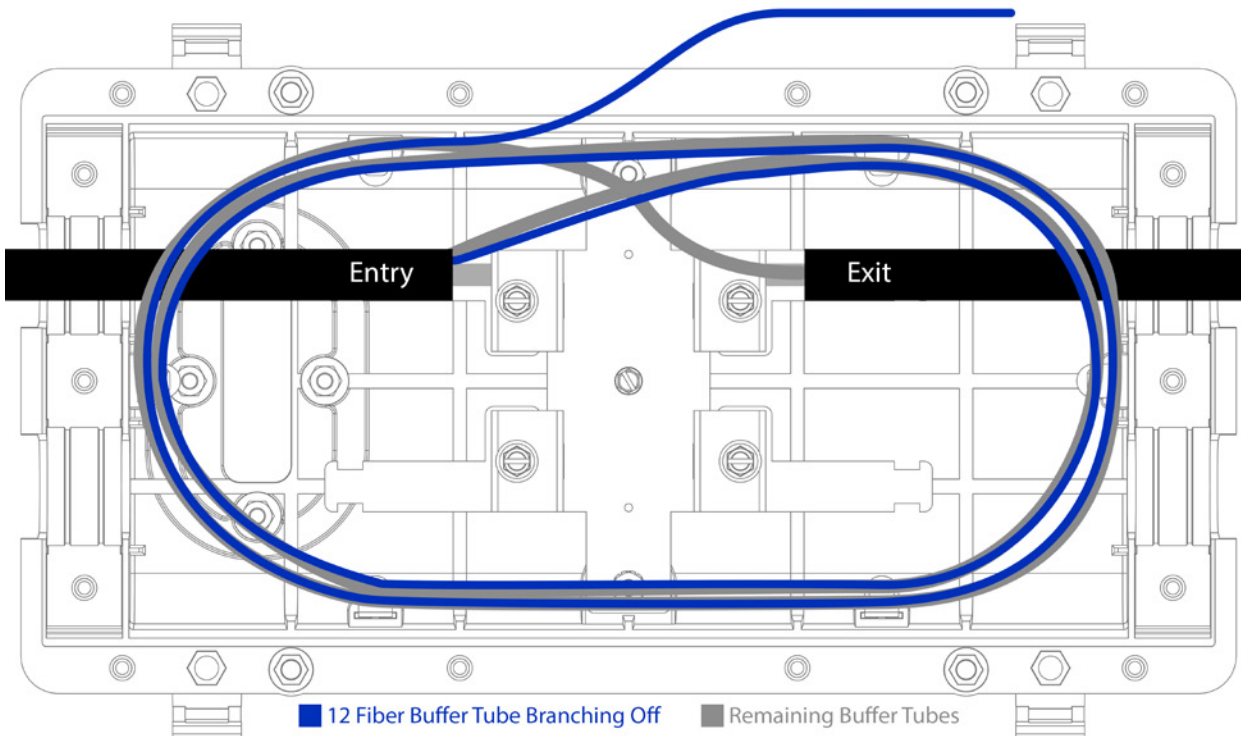

Figure 5.1B

Contact Us

North America	Europe, Middle East & Africa	Latin & South America
Tel: +1 440 366 6966	Tel: +1 440 366 6966	Tel: +1 954 499 9203
Fax: +1 440 366 6802	Fax: +1 440 366 6802	Mobile: +1 305 684 2388
Email: engsupport@gomultilink.com	Email: engsupport@gomultilink.com	Email: hquinones@gomultilink.com

6. Accessory List

Multilink's Starfighter Xpress supports various options of mounting kits, grommets accommodating vast cable diameters, additional accessories some of which are included with the Starfighter Xpress, and patch & splice options including bulkhead bracket kits, field installable connector kits, and pigtails.

Starfighter Xpress Entry/Exit 1" Grommets

Product Photo	Description	Stock ID
	Grommet Insert 1 Hole .3-.4" Cable	10-5552
	Grommet Insert 1 Hole .41-.5" Cable	10-5127
	Grommet Insert 1 Hole .51-.79" Cable	10-5128
	Grommet Insert 8 Hole .150" Cable w/Pins	10-6550
	Grommet Insert 6 Hole .265" Cable w/Pins	10-5129
	Grommet Insert 4 Hole .300" Cable w/Pins	10-6552
	Grommet Insert 4 Hole .350" Cable w/Pins	10-6002
	Grommet Insert 4 Hole .370" Cable w/Pins	10-5130
	Grommet Insert 4 Hole Flat Drop Cable w/Pins	10-5134

Starfighter Xpress Accessories

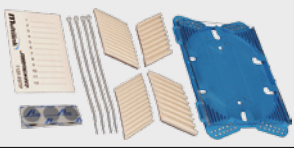
Product Photo	Description	Stock ID
	Velcro Strap 1/2 x 8"	651-030-10
	1120-SSTP Splice Tray Kit	072-059-10
	Grounding Kit	10-5424
	Grounding Kit for Dual Inline Fiber Optic Splice Closure	072-455-10

Starfighter Xpress Mounting Kits

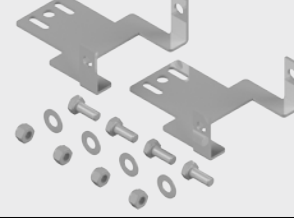
Product Photo	Description	Stock ID
	SFX Hanger Bracket Kit	072-240-10
	SFX Dual In-line Wall/Pole Mount Kit	072-450-20

Contact Us









North America	Europe, Middle East & Africa	Latin & South America
Tel: +1 440 366 6966 Fax: +1 440 366 6802 Email: engsupport@gomultilink.com	Tel: +1 440 366 6966 Fax: +1 440 366 6802 Email: engsupport@gomultilink.com	Tel: +1 954 499 9203 Mobile: +1 305 684 2388 Email: hquinones@gomultilink.com

Accessory List (Cont.)



Starfighter Xpress Ported Fittings

Product Photo	Description	Stock ID
	SC/APC IP Surelight Fitting	066-246-10
	SC/UPC IP Surelight Fitting	066-246-20
	LC/APC IP Surelight Fitting	066-247-10
	LC/UPC IP Surelight Fitting	066-247-20
	Surelight IPT Bulkhead Comp. w/ Scout Adapter & Optitap	065-082-10
	3/4" NPT Fitting Kit	072-454-10
	Removable Drop Port Plug	642-067-10

Starfighter Xpress Ported 3/4" Grommets

Product Photo	Description	Stock ID
	Grommet Insert 4 Hole .20-.24" Cable w/Pins	10-8084
	Grommet Insert 4 Hole .16-.20" Cable w/Pins	10-8087
	Grommet Insert 3 Hole .24-.28" Cable w/Pins	10-8085
	Grommet Insert 3 Hole .16-.20" Cable w/Pins	10-8090
	Grommet Insert 3 Hole Flat Drop Cable w/Pins	10-8092
	Grommet Insert 2 Hole .25-.29" Cable w/Pins	10-8091
	Grommet Insert 1 Hole .27-.31" Cable	10-8088
	Grommet Insert 1 Hole .32-.46" Cable	10-9999
	Grommet Strain Relief Plug 3/4" NPT Fitting	10-7970

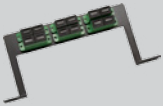
Starfighter Xpress Bulkhead Bracket Kits

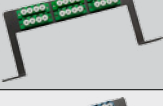
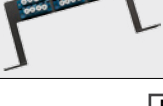
Product Photo	Description	Stock ID
	SC/APC Duplex Bulkhead Bracket Kit	072-451-10
	SC/UPC Duplex Bulkhead Bracket Kit	072-451-20
	LC/APC Quad Bulkhead Bracket Kit	072-451-30
	LC/UPC Quad Bulkhead Bracket Kit	072-451-40

Contact Us

North America	Europe, Middle East & Africa	Latin & South America
Tel: +1 440 366 6966 Fax: +1 440 366 6802 Email: engsupport@gomultilink.com	Tel: +1 440 366 6966 Fax: +1 440 366 6802 Email: engsupport@gomultilink.com	Tel: +1 954 499 9203 Mobile: +1 305 684 2388 Email: hquinones@gomultilink.com

Accessory List (Cont.)





Starfighter Xpress Pigtails

Product Photo	Description	Stock ID
	SC/APC 12 Fiber SM 3M Pigtail Spiral Wrapped	10-6418
	SC/UPC 12 Fiber SM 3M Pigtail Spiral Wrapped	10-6416
	LC/UPC 12 Fiber SM 3M Pigtail Spiral Wrapped	065-180-10
	SC/APC 12 Fiber SM 3M Pigtail Yellow Jacket	065-395-10
	SC/UPC 12 Fiber SM 3M Pigtail Yellow Jacket	065-371-10
	LC/APC 12 Fiber SM 3M Pigtail Yellow Jacket	065-437-10
	LC/UPC 12 Fiber SM 3M Pigtail Yellow Jacket	065-396-10
	SC/APC 4 Fiber SM 3M Pigtail Yellow Jacket	065-310-10
	SC/UPC 4 Fiber SM 3M Pigtail Yellow Jacket	066-493-10
	LC/APC 4 Fiber SM 3M Pigtail Yellow Jacket	066-494-10
	LC/UPC 4 Fiber SM 3M Pigtail Yellow Jacket	066-495-10
	SC/APC 1 Fiber SM 3M Pigtail Yellow Jacket	066-490-10
	SC/UPC 1 Fiber SM 3M Pigtail Yellow Jacket	065-286-10
	LC/APC 1 Fiber SM 3M Pigtail Yellow Jacket	066-491-10
LC/UPC 1 Fiber SM 3M Pigtail Yellow Jacket	066-492-10	

Starfighter Xpress Jumpers

Product Photo	Description	Stock ID
	SC/APC Simplex SM 4FT OFNR Fiber Jumper	066-480-10
	SC/UPC Simplex SM 4FT OFNR Fiber Jumper	066-481-10
	LC/APC Simplex SM 4FT OFNR Fiber Jumper	066-482-10
	LC/UPC Simplex SM 4FT OFNR Fiber Jumper	066-341-10

Starfighter Xpress Field Installable Kits

Product Photo	Description	Stock ID
	SC/APC SM Field Installable Kit	066-025-10
	SC/UPC SM Field Installable Kit	066-024-10
	LC/APC SM Field Installable Kit	066-131-10
	LC/UPC SM Field Installable Kit	066-029-10

North America	Europe, Middle East & Africa	Latin & South America
Tel: +1 440 366 6966 Fax: +1 440 366 6802 Email: engsupport@gomultilink.com	Tel: +1 440 366 6966 Fax: +1 440 366 6802 Email: engsupport@gomultilink.com	Tel: +1 954 499 9203 Mobile: +1 305 684 2388 Email: hquinones@gomultilink.com

Contact Us

multilink®

Innovation At Work



Scan QR for website.

Multilink, Inc
 580 Ternes Ln
 Elyria, OH 44035
 Tel: (440) 366-6966
 Fax: (440) 366-6802



facebook.com/GoMultilink



twitter.com/GoMultilink



youtube.com/GoMultilink

North America	Europe, Middle East & Africa	Latin & South America
Tel: +1 440 366 6966	Tel: +1 440 366 6966	Tel: +1 954 499 9203
Fax: +1 440 366 6802	Fax: +1 440 366 6802	Mobile: +1 305 684 2388
Email: engsupport@gomultilink.com	Email: engsupport@gomultilink.com	Email: hquinones@gomultilink.com

Visit gomultilink.com for new product releases!