

REV.	ECH #	DESCRIPTION OF CHANGE	DATE	BY	MFG ENG
01	N/A	INITIAL RELEASE	07/13/04	L.P.K.	
02	2111	UPDATED ITEM #6	07/29/10	L.P.K.	

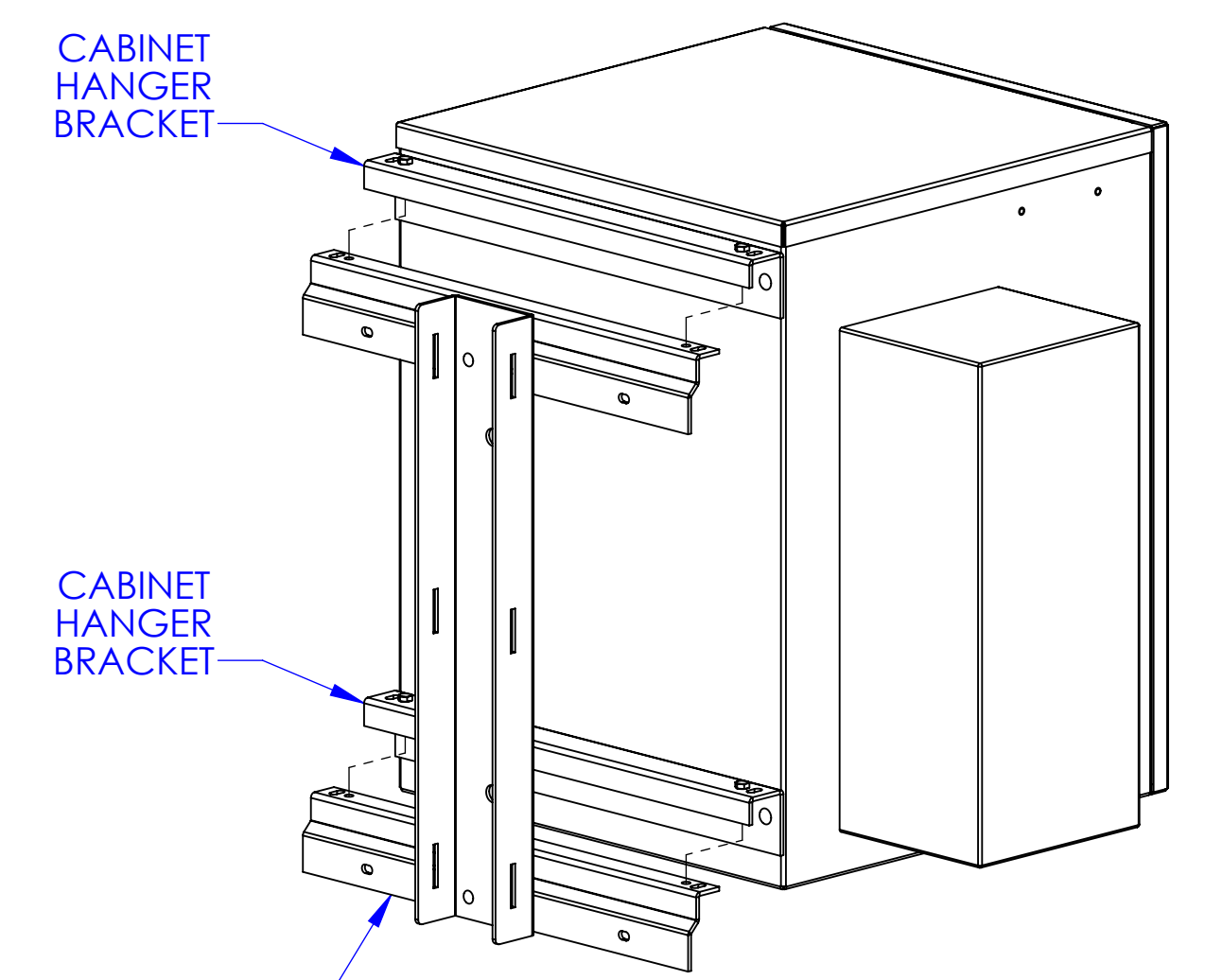
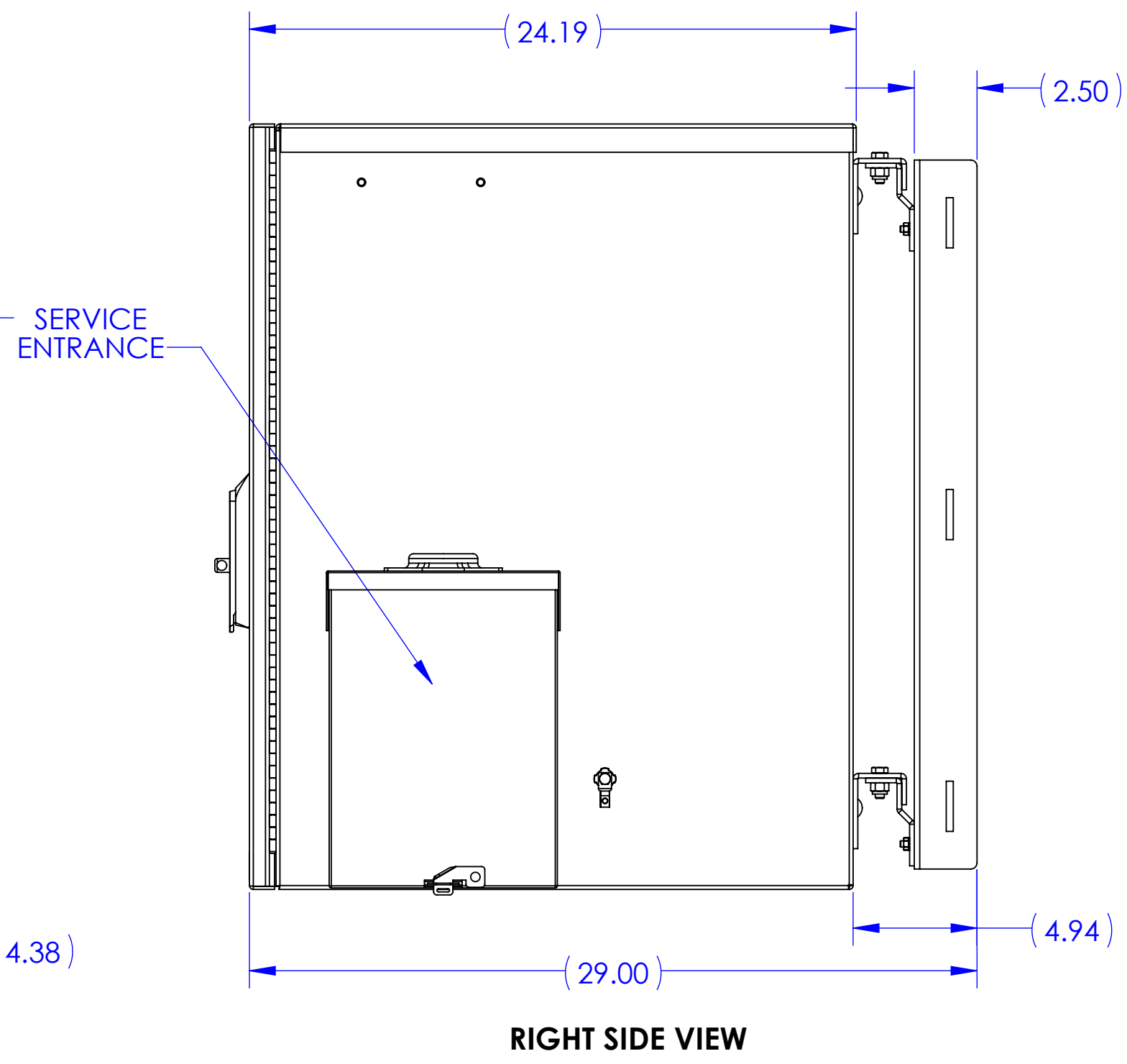
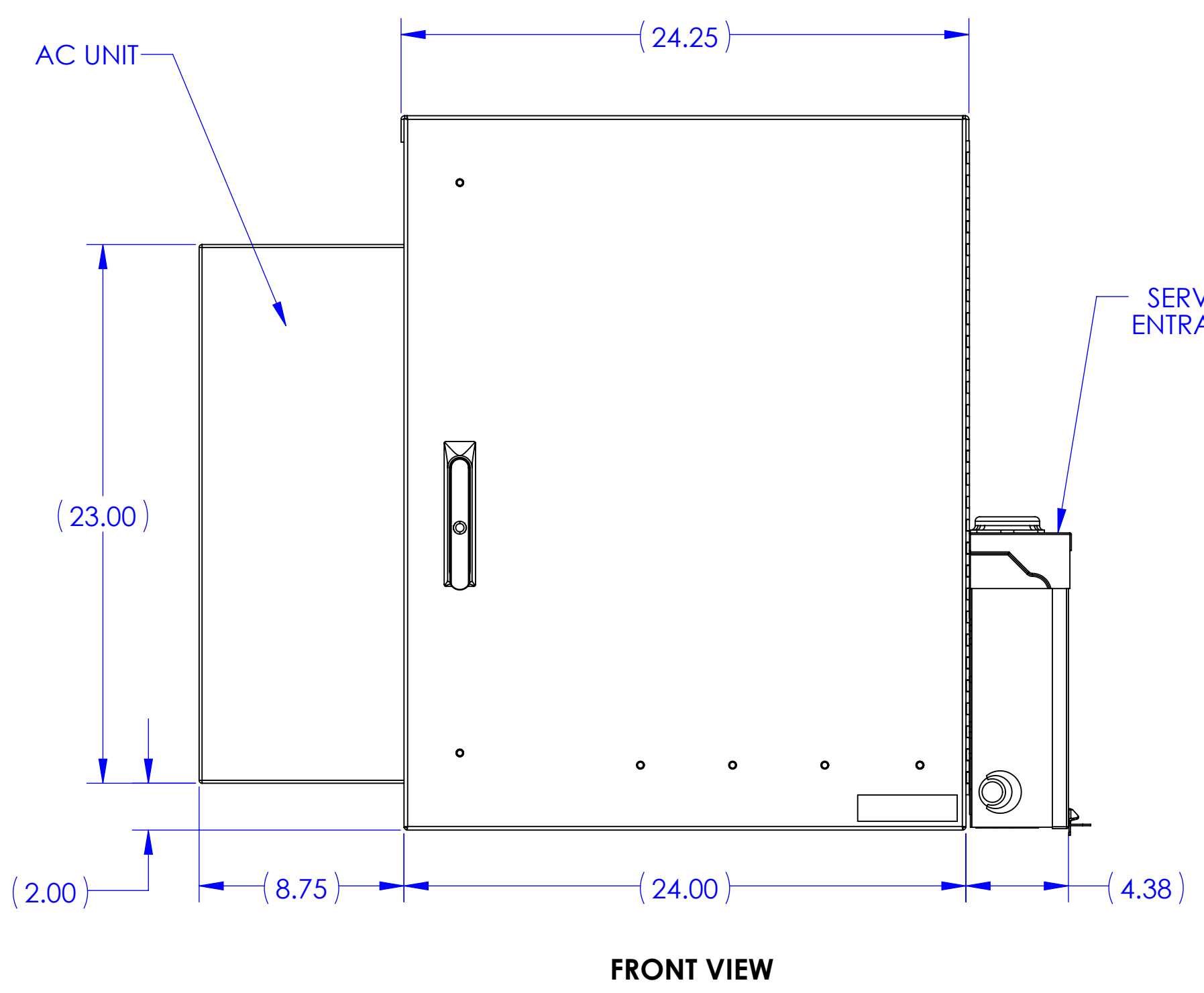
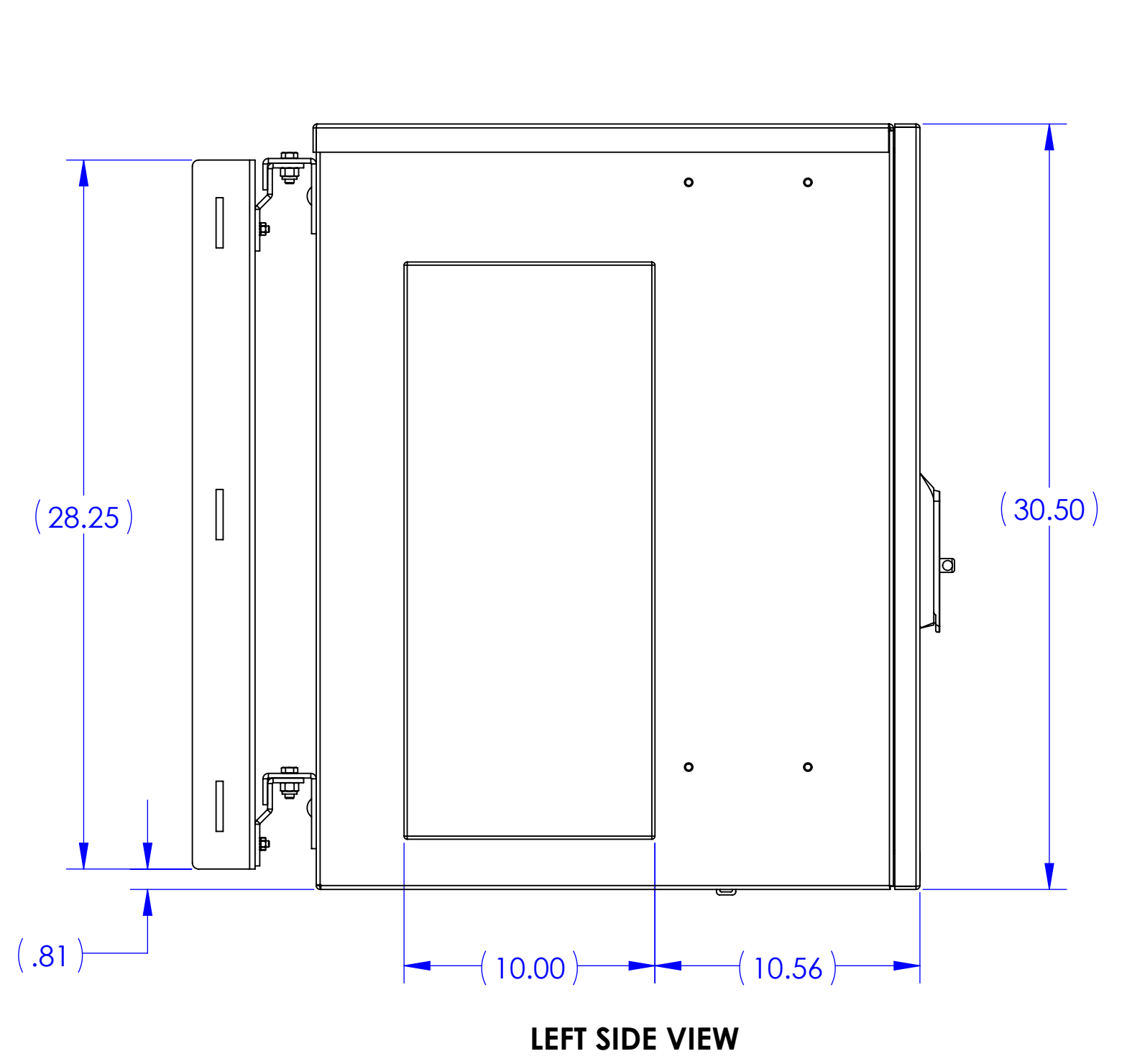
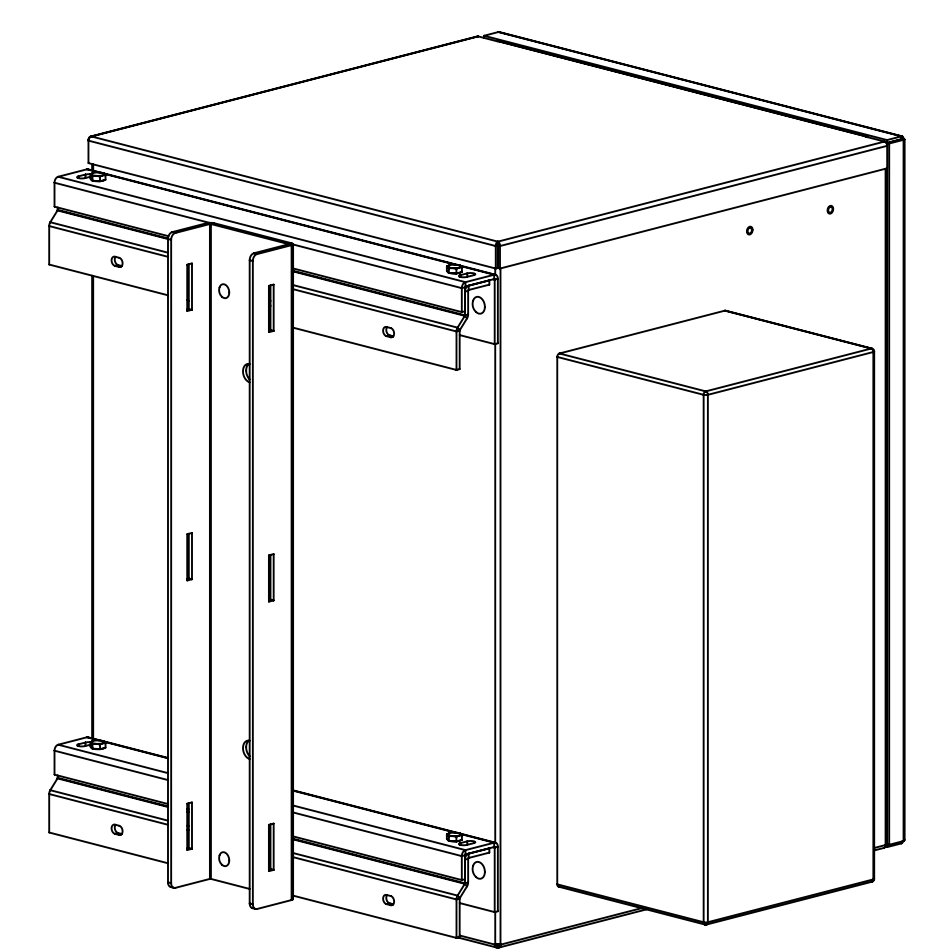
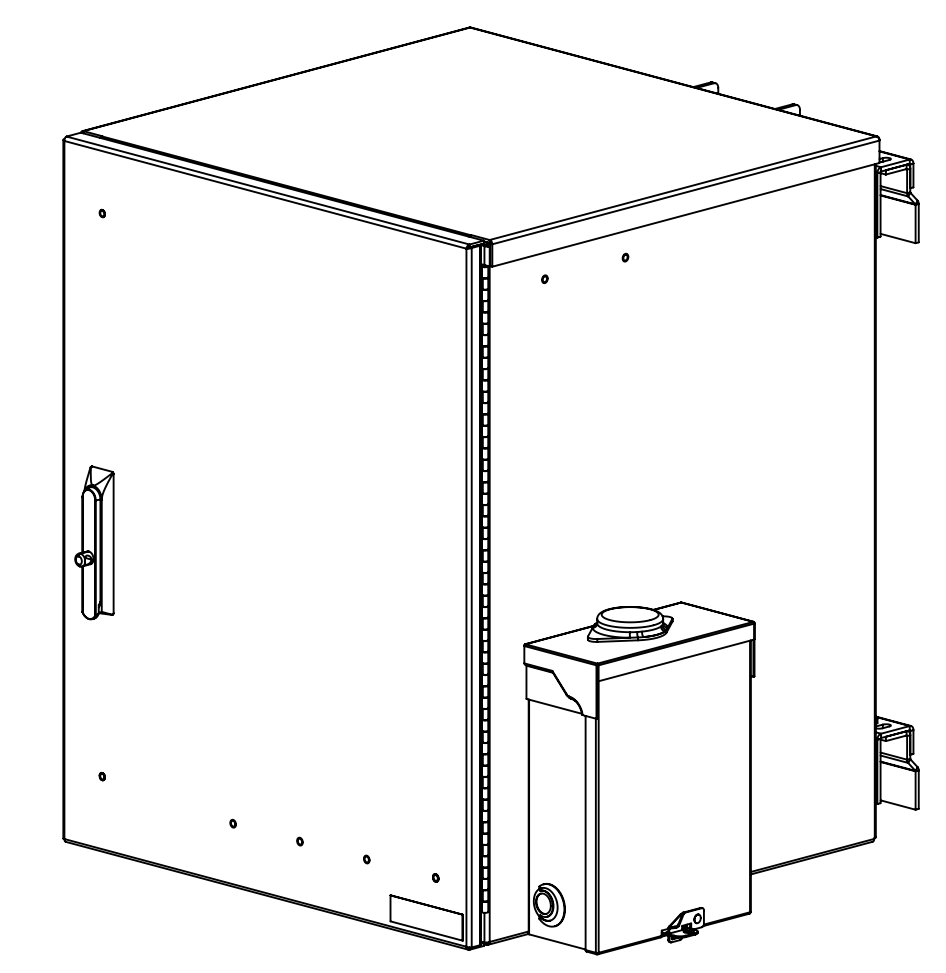
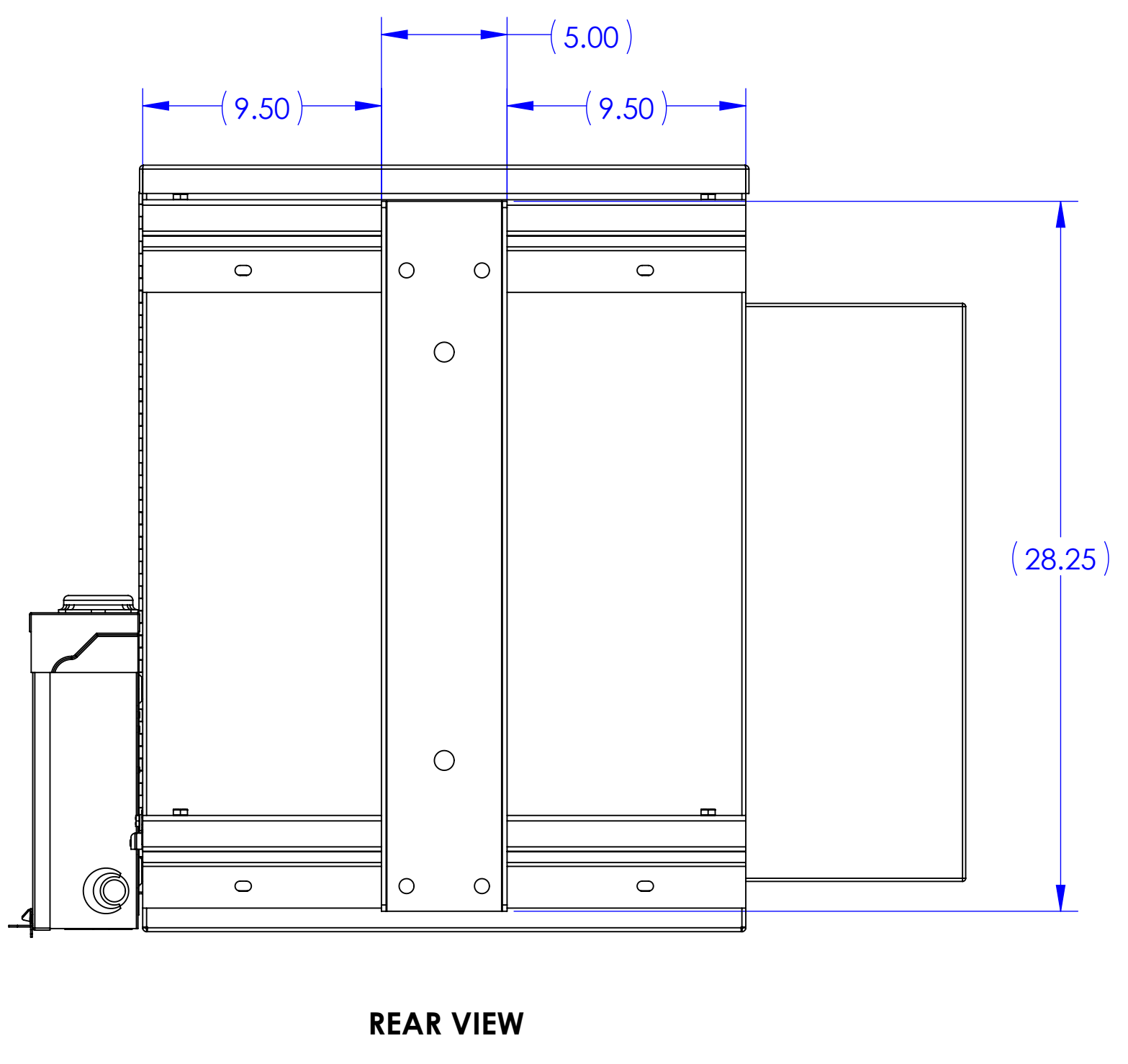
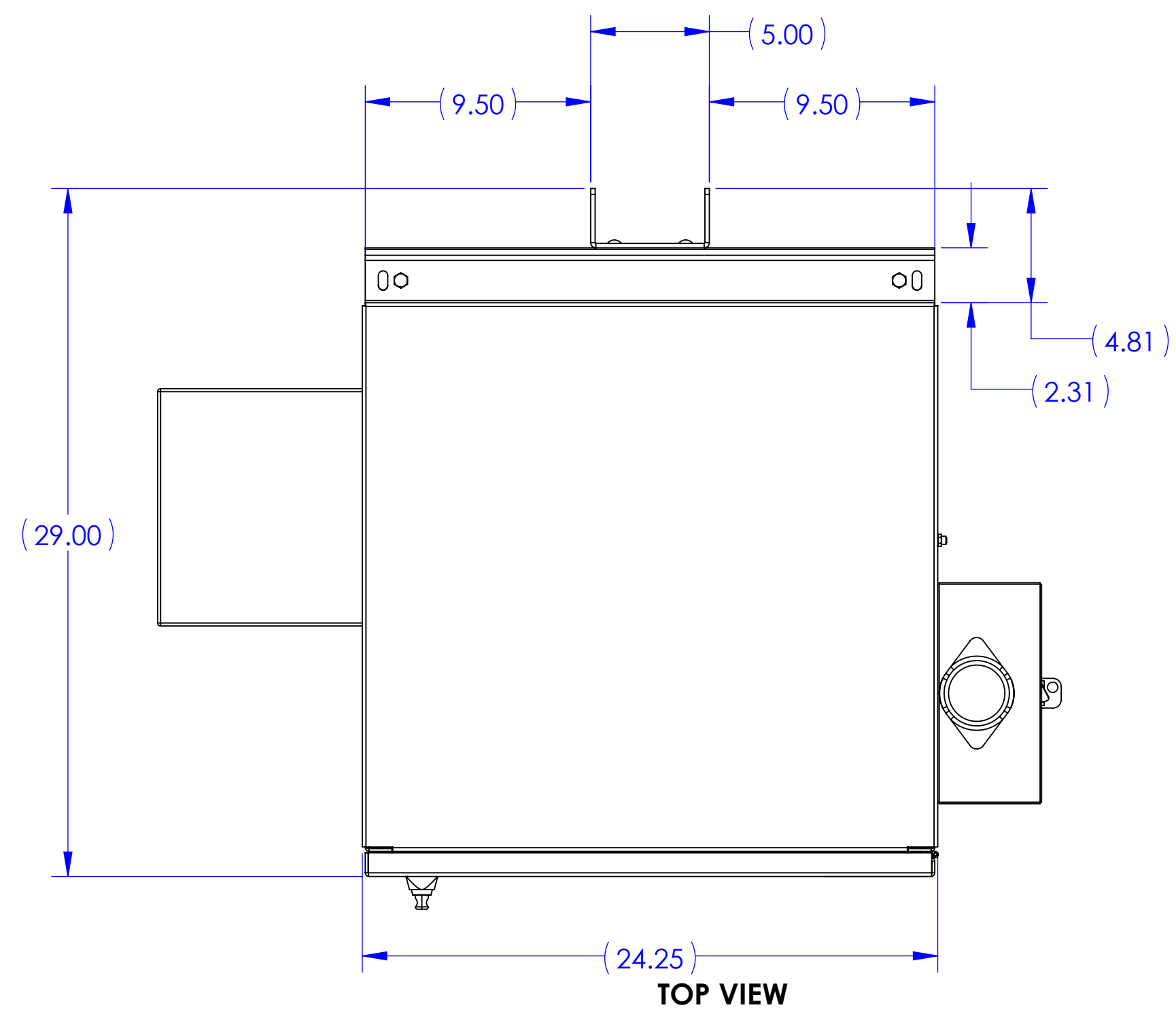
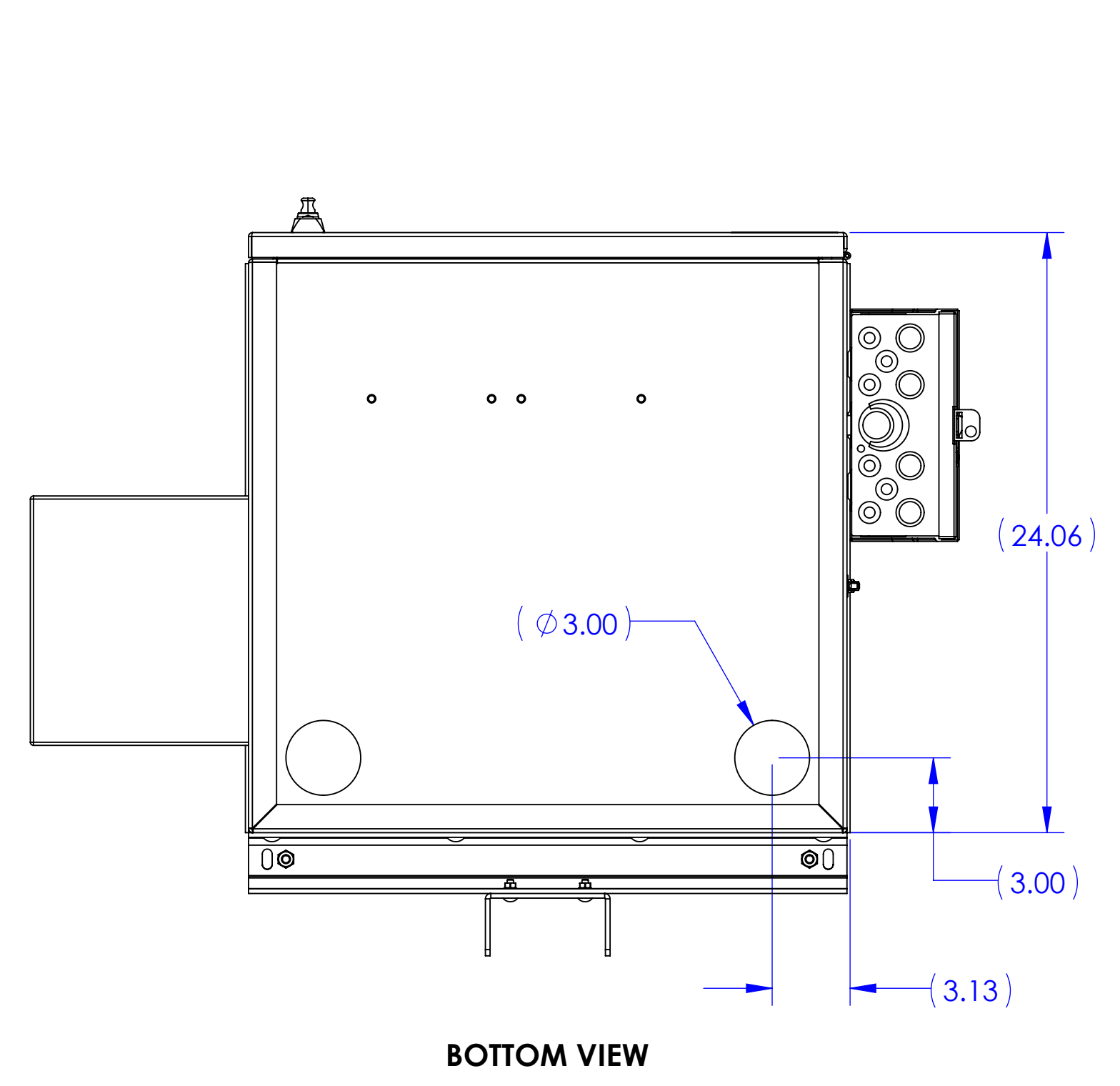

NOTE:
 1. CABINET MATERIAL: 1/8" ALUMINUM
 2. MOUNTING BRKT MATERIAL: 3/16 STEEL
 3. CABINET / BRKT FINISH: GRAY POLYESTER POWDERCOAT

UNLESS OTHERWISE SPECIFIED DIMENSIONS ARE IN INCHES TOLERANCES ARE: FRACTIONS: .XXX ± .010 DECIMALS: .XX ± .005 ANGLES: ± 1°		THIS DOCUMENT AND THE INFORMATION CONTAINED HEREIN ARE CONFIDENTIAL & PROPRIETARY TO MULTILINK AND SHALL NOT BE COPIED OR DISCLOSED TO OTHERS WITHOUT THE WRITTEN CONSENT FROM MULTILINK. THE INFORMATION IS TO BE KEPT SECRET.		Multilink	
MATERIAL: SEE BOM		DRAWN BY: L.P.K. DATE: 07/13/2006		PMO-14RU-N4-AC-PG ASSY ENVIRON-CAB GRAY W/JAC	
FINISH: PROTEC GRAY		CHECKED: DATE:		DWG. NO. 030-152-10REF	
DO NOT SCALE DRAWING		QUALITY ENG. DATE:		SCALE: 1:1.5 (CAD FILE: 030-152-10REF) SHEET: 1 OF 1	