

REV.	ECN #	DESCRIPTION OF CHANGE	DATE	BY	MFG ENG
01	N/A	INITIAL RELEASE	03/13/15	SJK	

NOTES:

1. MOUNTING ANGLES ARE CONFIGURABLE FOR 19" RACK (SHOWN) AND 23" RACK.
2. MOUNTING ANGLES HAVE THREE MOUNTING POSITIONS, FOR 19" RACK FORWARD MOST SHOWN.
3. MOUNTING ANGLES HAVE THREE MOUNTING POSITIONS FOR 23" RACK FORWARD MOST SHOWN.
4. STANDARD COLOR - BLACK.
5. SPLICE TRAYS AND ADAPTOR PANELS SHOWN ARE FOR REFERENECE ONLY.

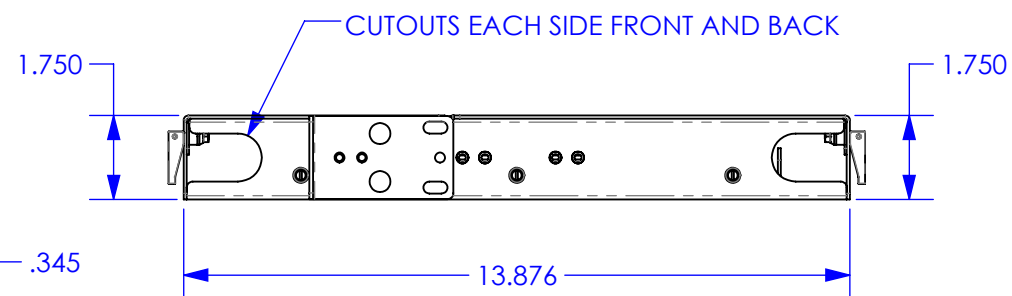
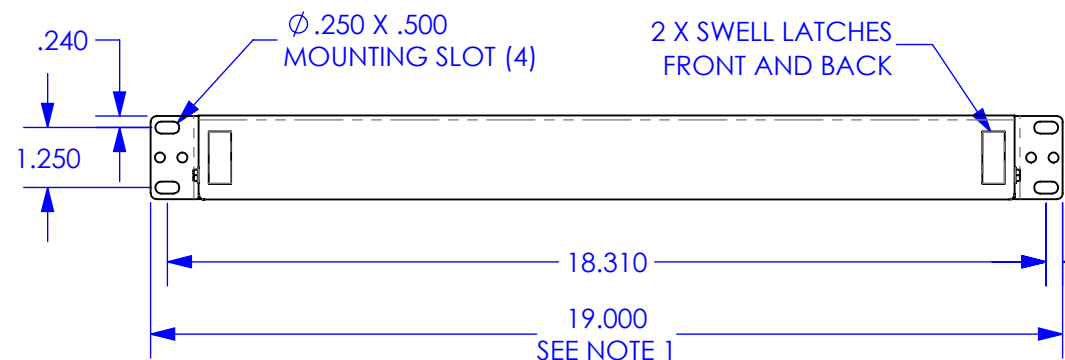
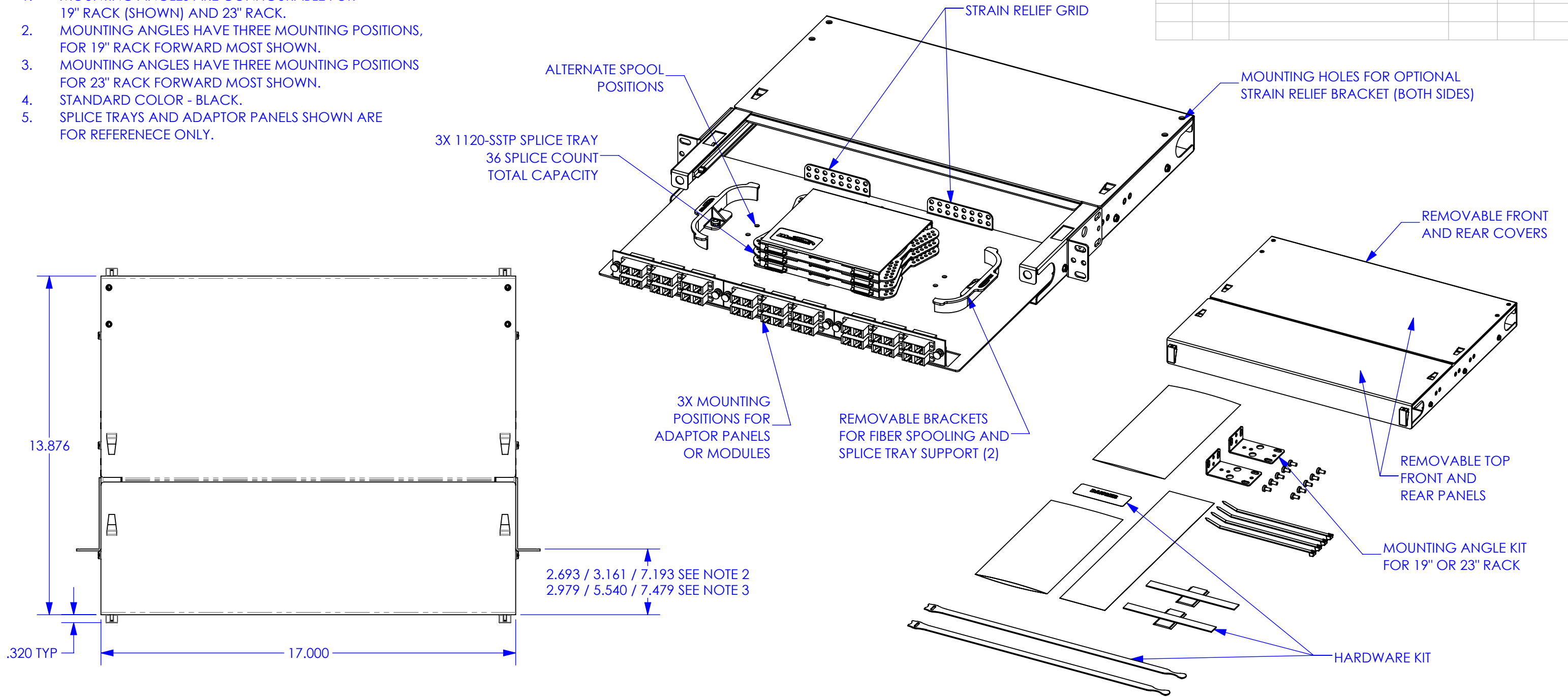

UNLESS OTHERWISE SPECIFIED DIMENSIONS ARE IN INCHES
TOLERANCES ARE:
FRACTIONS: DECIMALS: ANGLES:
±1/32 .XX±.03 ±1°
.XXX±.010
ALL FLATS TO BE ±.005
NO SHARP EDGES OR BURRS ALLOWED
MATERIAL: SEE B.O.M.
FINISH: BLACK TEXTURED
DO NOT SCALE DRAWING

THIS DOCUMENT AND THE INFORMATION CONTAINED THEREIN ARE CONFIDENTIAL & PROPRIETARY TO MULTILINK AND MAY NOT BE COPIED OR DISCLOSED TO OTHERS WITHOUT A WRITTEN CONSENT FROM MULTILINK. THE INFORMATION IS TO BE PROMPTLY RETURNED TO MULTILINK UPON REQUEST.
DRAWN BY: SJK DATE: 03/13/15
CHECKED: DATE:
MFG ENG: DATE:
QUALITY ENG: DATE:

Multilink

FRM-1RU-3X-TS-S-LC BK
-ECONOMY VERSION

SIZE B DWG. NO. 045-903-10REF REV. 01
SCALE: 1:4 CAD FILE: 045-903-10REF SHEET: 1 OF 1