

REV.	ECN #	DESCRIPTION OF CHANGE	DATE	BY	MFG ENG
01	N/A	INITIAL RELEASE	5/20/13	TT	

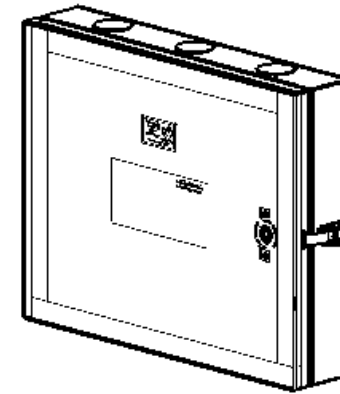

STAINLESS STEEL
DOOR HINGE



216 CAN WRENCH
QUARTER TURN
COMPRESSION
LATCH LOCK

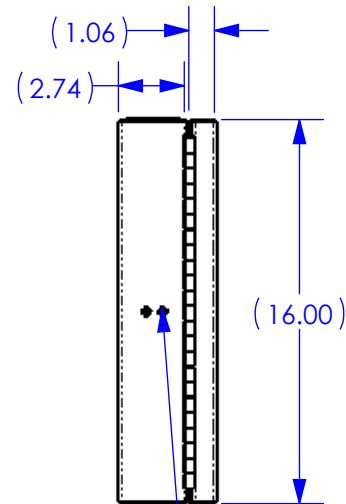
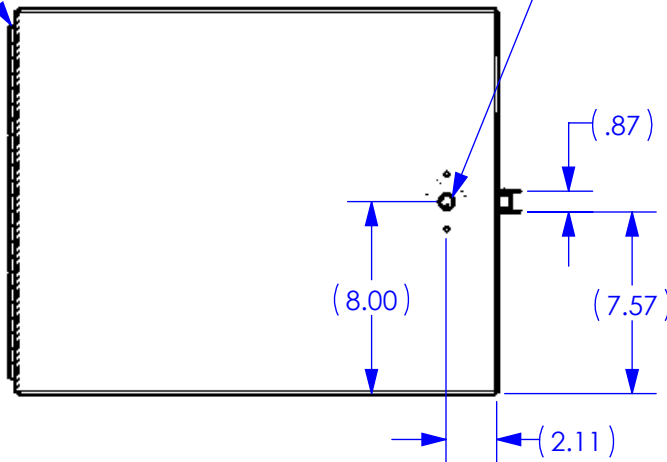

OPTIONAL
DRAW LATCH
MOUNTING WHEN
DOOR IS MOUNTED
RIGHT HAND SWING

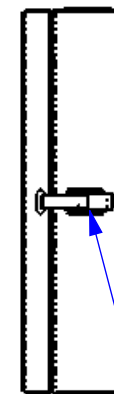

OVER CENTER
DRAW LATCH
STAINLESS STEEL
W/PADLOCK
OPTION

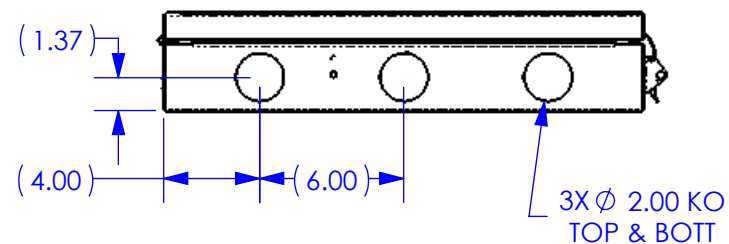
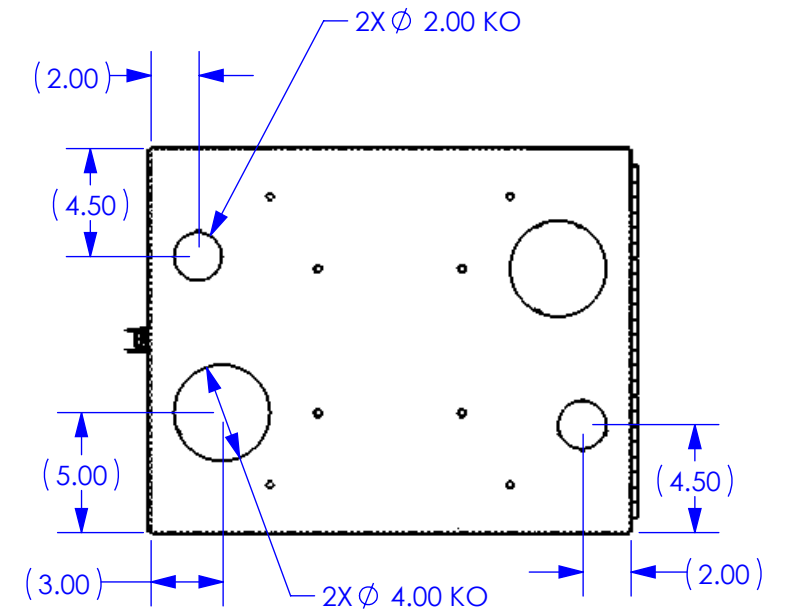

NOTE:

- ENCLOSURE MATERIAL:
16 GA. / 0.063" GALVANNEALED STEEL
- ENCLOSURE FINISH:
GRAY POLYESTER POWDER COAT
- STAINLESS STEEL HARDWARE

UNLESS OTHERWISE SPECIFIED
DIMENSIONS ARE IN INCHES
TOLERANCES ARE:

FRACTIONS: DECIMALS: ANGLES:
± 1/32 .XX ± .03 ± 1°
.XXX ± .010

ALL FLATS TO BE ± .005

**NO SHARP EDGES OR
BURRS ALLOWED**

MATERIAL:
SEE B.O.M.

FINISH:
ASA-70 GRAY

DO NOT SCALE DRAWING

THIS DOCUMENT AND THE INFORMATION
CONTAINED THEREIN ARE CONFIDENTIAL
& PROPRIETARY TO MULTILINK AND MAY
NOT BE COPIED OR DISCLOSED TO OTHERS
WITHOUT A WRITTEN CONSENT FROM
MULTILINK. THE INFORMATION IS TO BE
PROMPTLY RETURNED TO MULTILINK UPON
REQUEST.

DRAWN BY: TT DATE: 5/20/13

CHECKED: DATE:

MFG ENG: DATE:

QUALITY ENG: DATE:

Multilink

RN1HN4-20164-1CV1DL-
C-PG-Y-S

SIZE DWG. NO. REV.
B 050-155-30-REF 01

SCALE: 1:5 CAD FILE: 050-155-30-REF SHEET: 1 OF 2

REV.	ECN #	DESCRIPTION OF CHANGE	DATE	BY	MFG ENG
01	N/A	INITIAL RELEASE	5/20/13	TT	

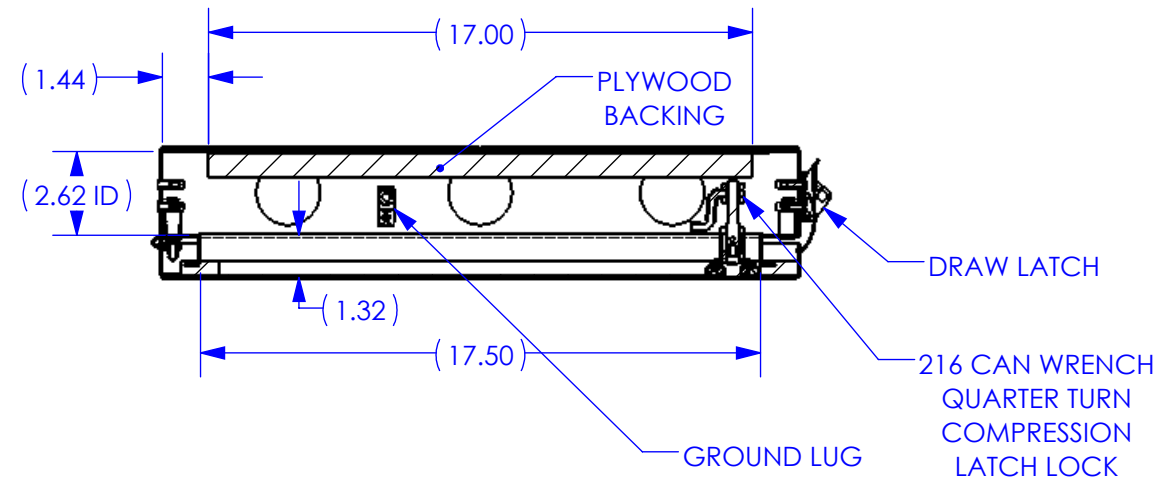

NOTE:

1. UNIT EQUIPPED WITH 3/4" PLYWOOD, GROUND LUG, DRAW LATCH AND WEATHERPROOF GASKETING.
2. THE ENTIRE DOOR ASSEMBLY AND DRAW LATCH IS REVERSIBLE AND CAN BE MOUNTED ON THE RIGHT OR LEFT HAND SIDE OF THE ENCLOSURE.
3. THE MOUNTING BRACKET KIT FOR THE ENCLOSURE IS SOLD SEPARATELY.

SECTION A-A
SCALE 1 : 6

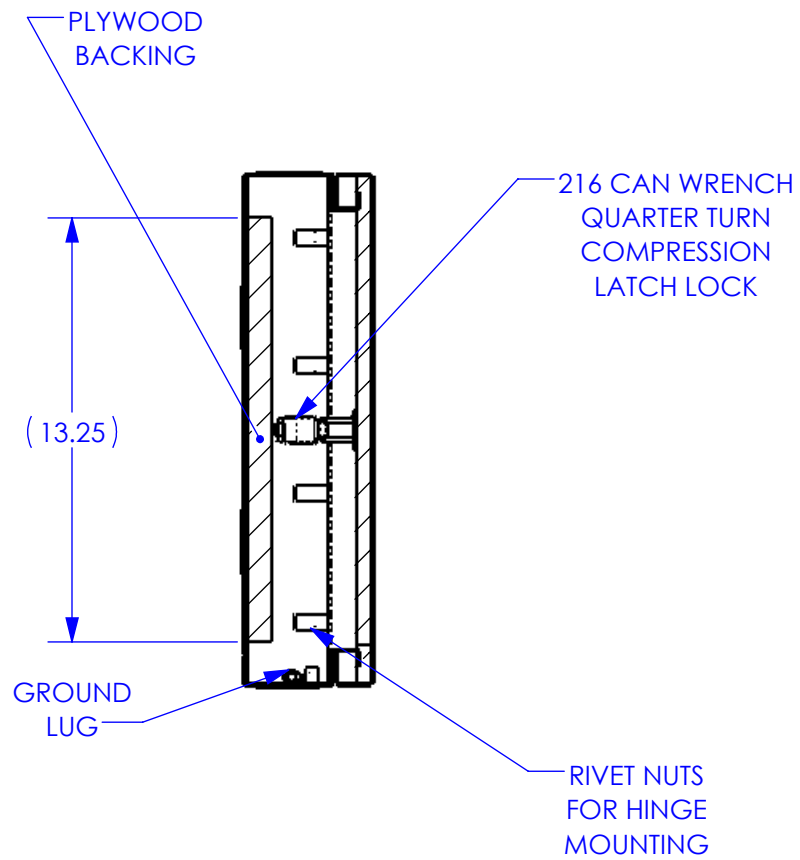

SECTION B-B
SCALE 1 : 6

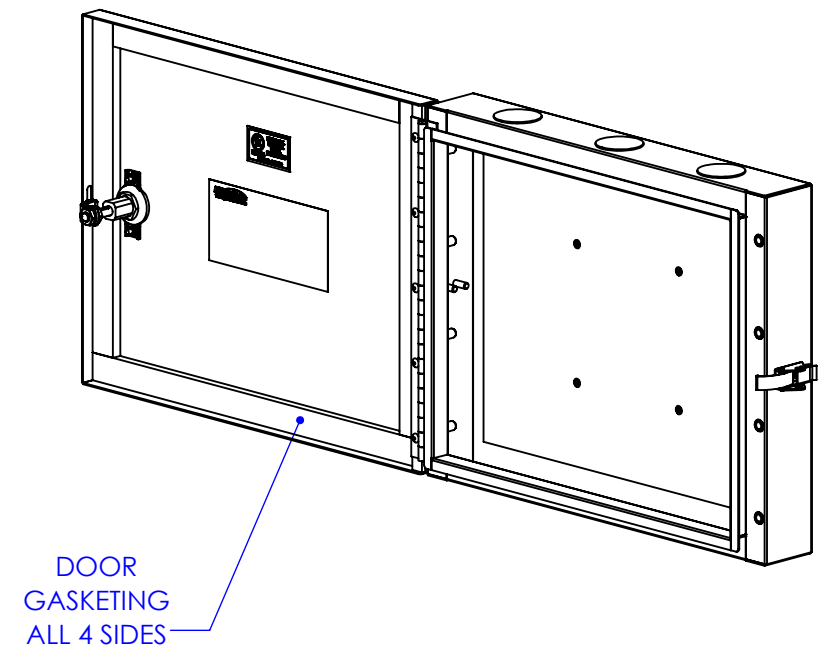
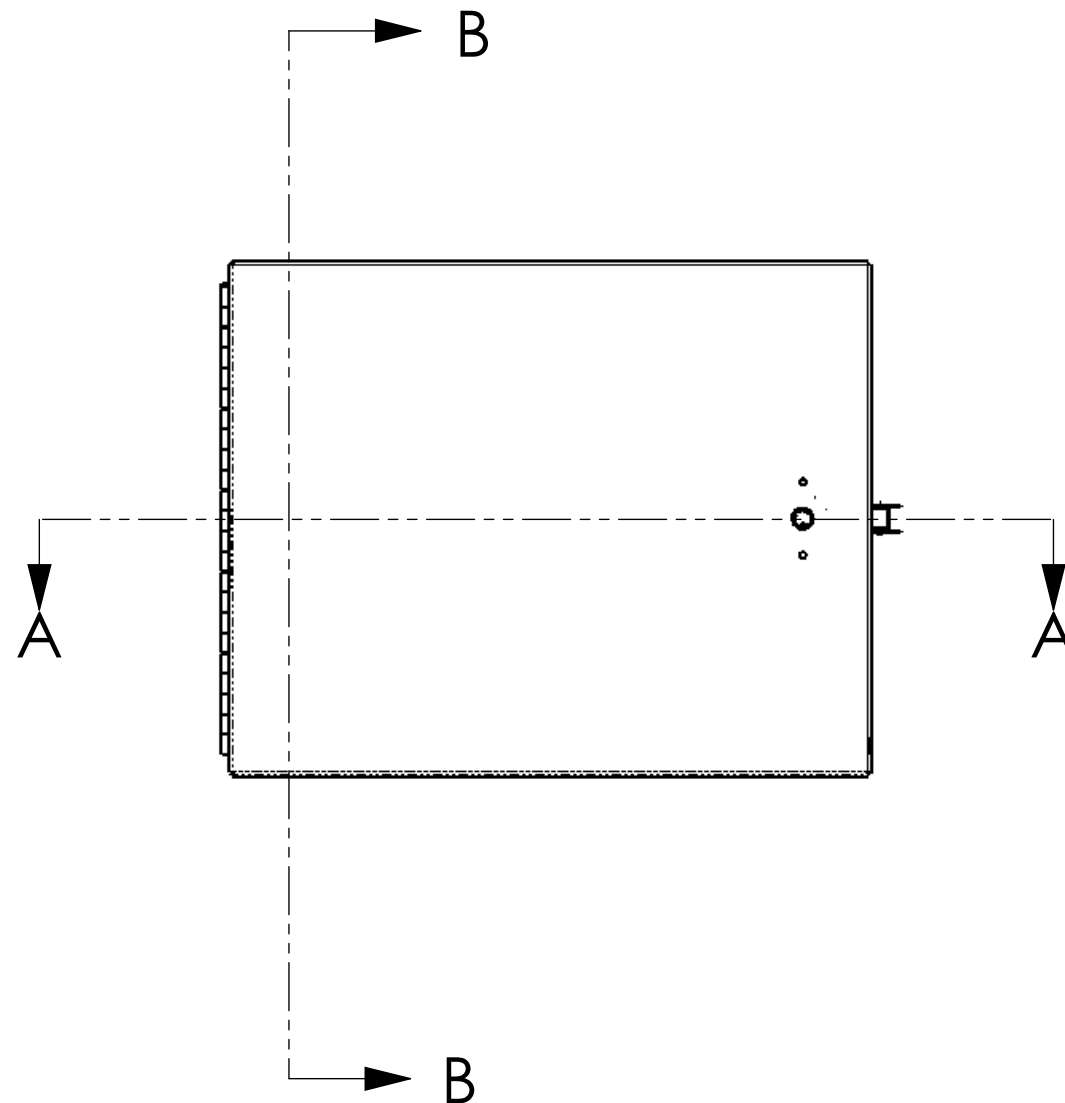

UNLESS OTHERWISE SPECIFIED DIMENSIONS ARE IN INCHES TOLERANCES ARE: FRACTIONS: ±1/32 DECIMALS: .XX=±.03 ANGLES: ±1° .XXX=±.010 ALL FLATS TO BE ±.005		<p>Multilink</p> <p>RN1HN4-20164-1CV1DL-C-PG-Y-S</p>
<p>NO SHARP EDGES OR BURRS ALLOWED</p> <p>MATERIAL: SEE B.O.M. FINISH: ASA-70 GRAY DO NOT SCALE DRAWING</p>		
<p>THIS DOCUMENT AND THE INFORMATION CONTAINED THEREIN ARE CONFIDENTIAL & PROPRIETARY TO MULTILINK AND MAY NOT BE COPIED OR DISCLOSED TO OTHERS WITHOUT A WRITTEN CONSENT FROM MULTILINK. THE INFORMATION IS TO BE PROMPTLY RETURNED TO MULTILINK UPON REQUEST.</p>	<p>DRAWN BY: TT DATE: 5/20/13</p> <p>CHECKED: DATE:</p> <p>MFG ENG: DATE:</p> <p>QUALITY ENG: DATE:</p>	<p>SCALE: 1:5 DWG. NO. 050-155-30-REF REV. 01</p> <p>CAD FILE: 050-155-30-REF SHEET: 2 OF 2</p>