

REV.	ECN #	DESCRIPTION OF CHANGE	DATE	BY	MFG ENG
02	2388	ADDED ITEM 12	5/25/11	TT	
03	2424	ADDED UL LABELS	6/27/11	TT	
04	2553	SEE ECN	12/21/11	TT	
05	3065	WAS 035-140-10/NOW 035-151-10	6/19/13	TT	

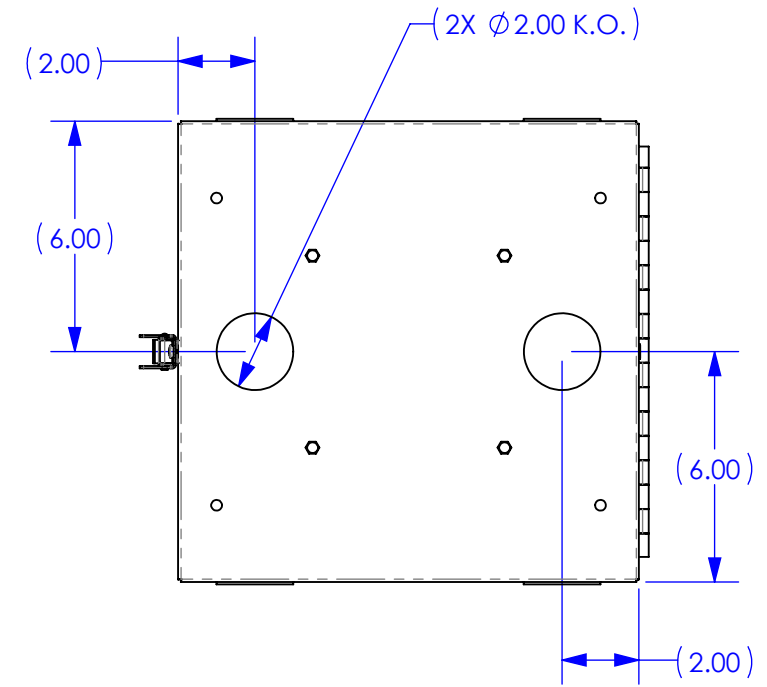

OVER CENTER DRAW LATCH STAINLESS STEEL W/PADLOCK OPTION

- NOTE:
- ENCLOSURE MATERIAL:  
16 GA. / 0.063" GALVANNEAED STEEL
  - ENCLOSURE FINISH:  
LIGHT GRAY POLYESTER POWDER COAT
  - STAINLESS STEEL HARDWARE

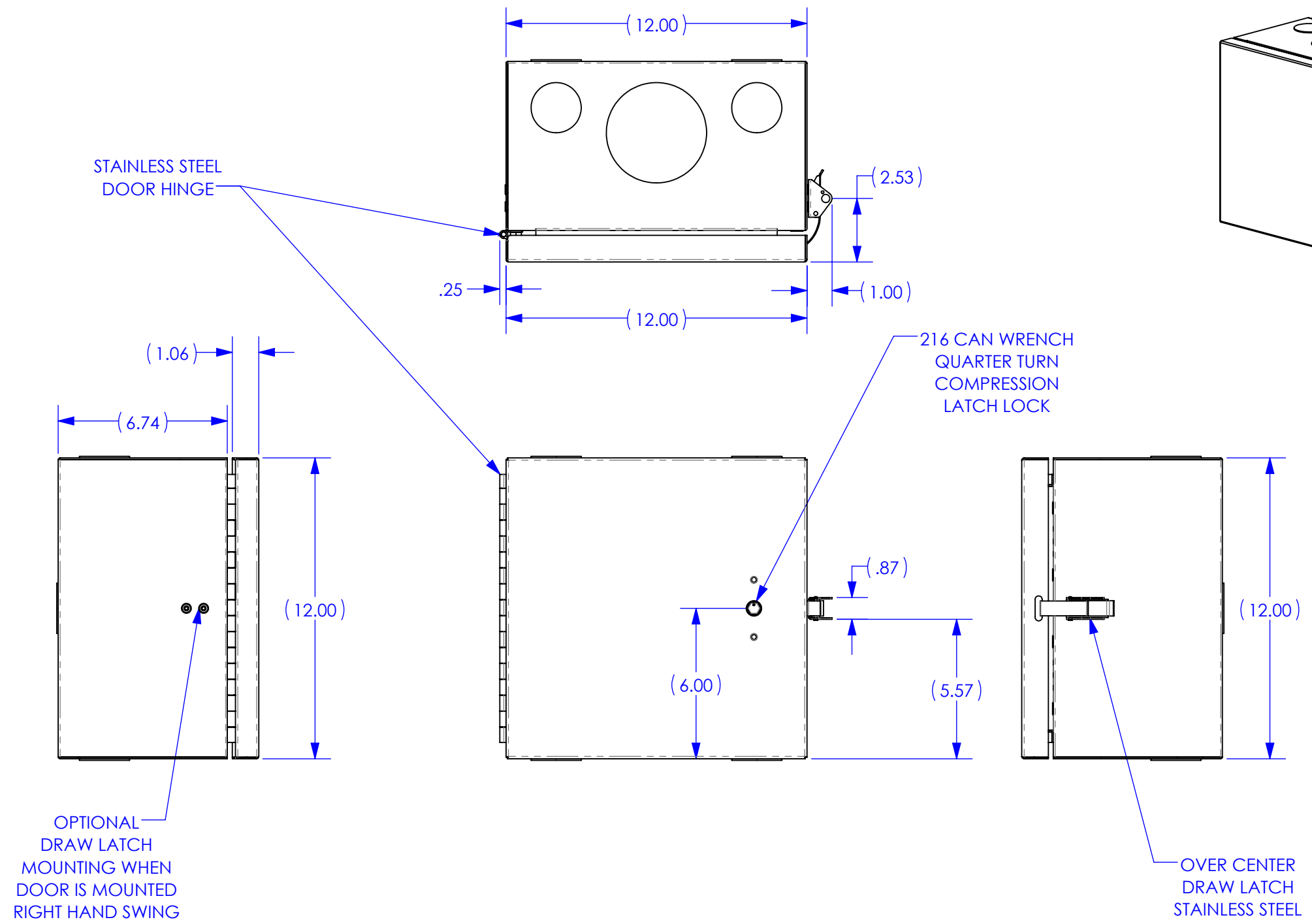
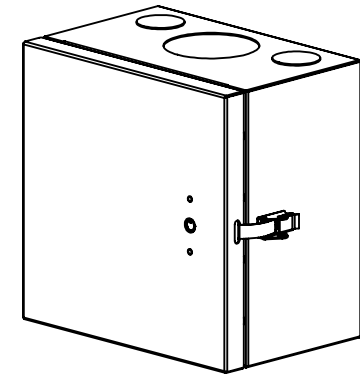
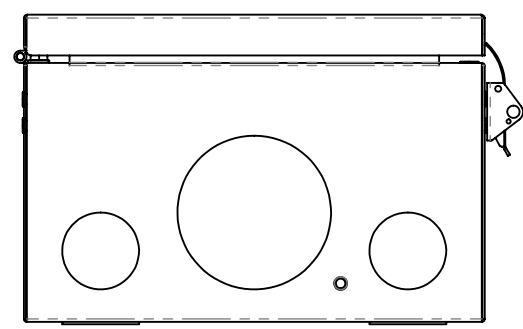

UNLESS OTHERWISE SPECIFIED DIMENSIONS ARE IN INCHES TOLERANCES ARE: FRACTIONS: ±1/32    DECIMALS: .XX±.03    ANGLES: ±1° .XXX±.010		THIS DOCUMENT AND THE INFORMATION CONTAINED THEREIN ARE CONFIDENTIAL & PROPRIETARY TO MULTILINK AND MAY NOT BE COPIED OR DISCLOSED TO OTHERS WITHOUT A WRITTEN CONSENT FROM MULTILINK. THE INFORMATION IS TO BE PROMPTLY RETURNED TO MULTILINK UPON REQUEST.	<b>Multilink</b>
ALL FLATS TO BE ±.005			
<b>NO SHARP EDGES OR BURRS ALLOWED</b>		DRAWN BY: TT	DATE: 4/15/11
MATERIAL: 16 GA/0.063 G-NEAL		CHECKED:	DATE:
FINISH: ASA-70 GRAY		MFG ENG:	DATE:
DO NOT SCALE DRAWING		QUALITY ENG:	DATE:
		RN1HN4-12128-1CV1DL-C-PG-Y-S	
SIZE B	DWG. NO. 050-156-30-REF	REV. 05	
SCALE: 1:5	CAD FILE: 050-156-30-REF	SHEET: 1	OF 2

REV.	ECN #	DESCRIPTION OF CHANGE	DATE	BY	MFG ENG
02	2388	ADDED ITEM 12	5/25/11	TT	
03	2424	ADDED UL LABELS	6/27/11	TT	
04	2553	SEE ECN	12/21/11	TT	
05	3065	WAS 035-140-10/NOW 035-151-10	6/19/13	TT	

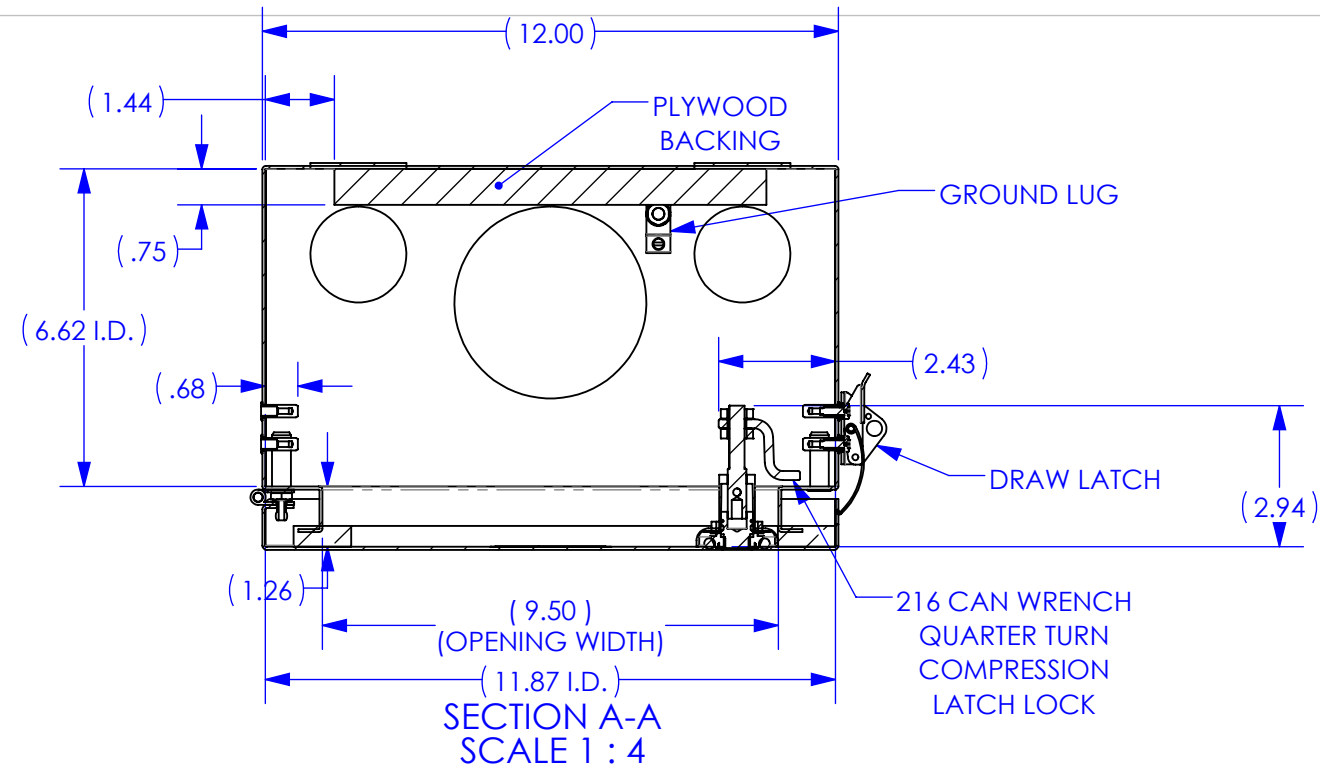

NOTE:

1. UNIT EQUIPPED WITH 3/4" PLYWOOD, GROUND LUG, DRAW LATCH AND WEATHERPROOF GASKETING.
2. THE ENTIRE DOOR ASSEMBLY AND DRAW LATCH IS REVERSIBLE AND CAN BE MOUNTED ON THE RIGHT OR LEFT HAND SIDE OF THE ENCLOSURE.
3. THE MOUNTING BRACKET KIT FOR THE ENCLOSURE IS SOLD SEPARATELY.

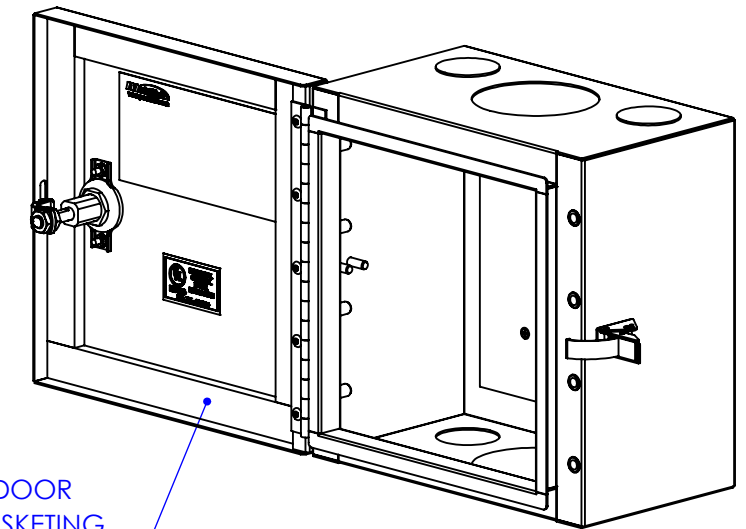
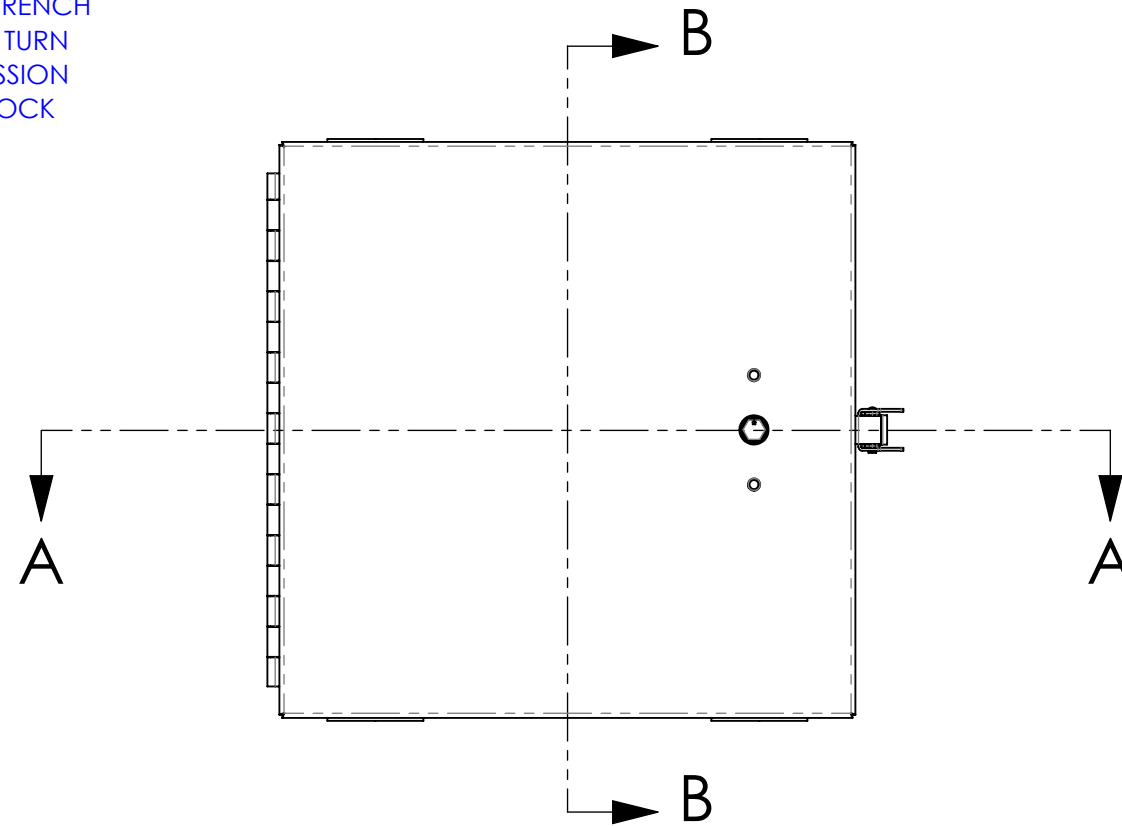
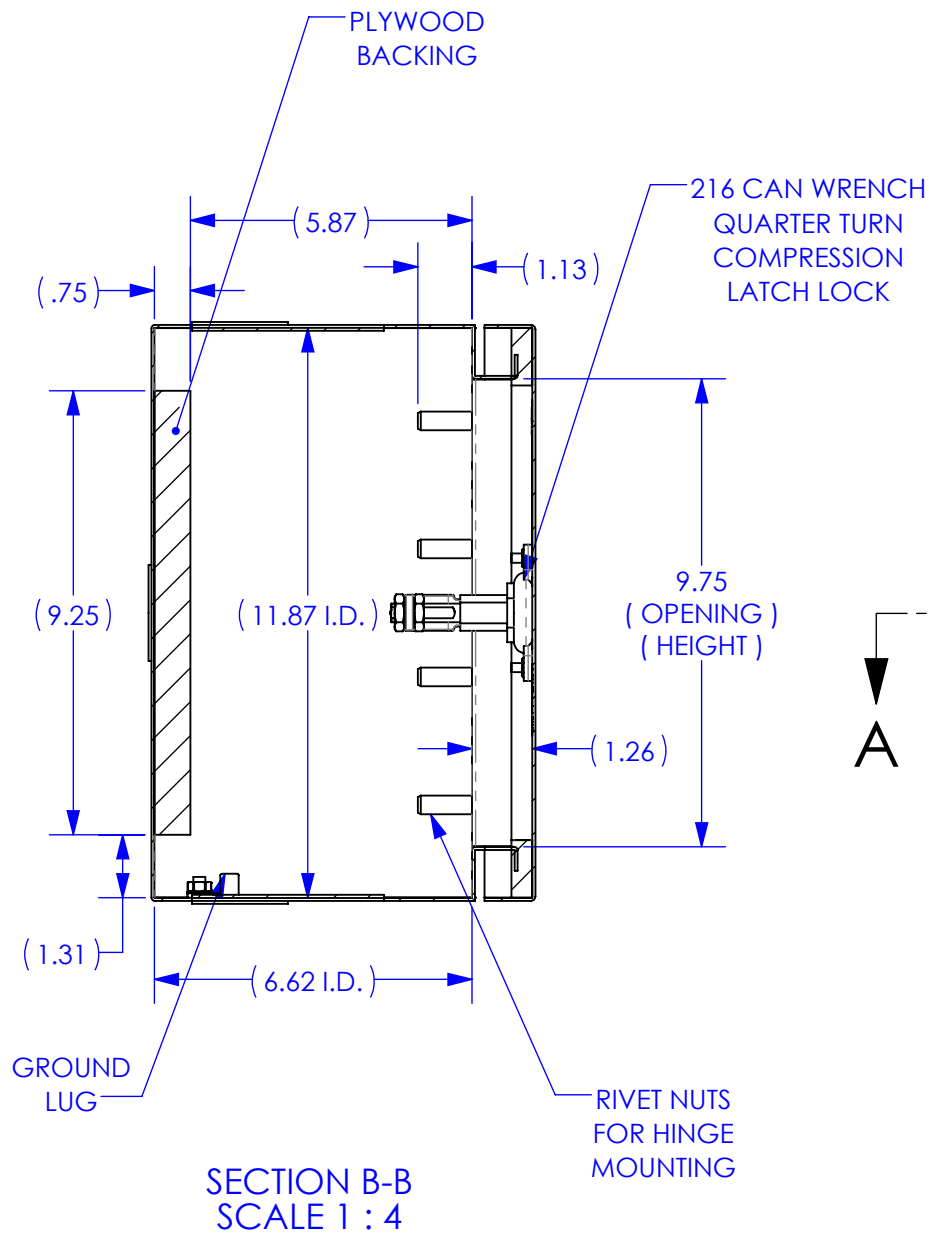

UNLESS OTHERWISE SPECIFIED DIMENSIONS ARE IN INCHES TOLERANCES ARE: FRACTIONS: ±1/32    DECIMALS: .XX=±.03    ANGLES: ±1° .XXX=±.010 ALL FLATS TO BE ±.005		THIS DOCUMENT AND THE INFORMATION CONTAINED THEREIN ARE CONFIDENTIAL & PROPRIETARY TO MULTILINK AND MAY NOT BE COPIED OR DISCLOSED TO OTHERS WITHOUT A WRITTEN CONSENT FROM MULTILINK. THE INFORMATION IS TO BE PROMPTLY RETURNED TO MULTILINK UPON REQUEST.	<b>Multilink</b>	
<b>NO SHARP EDGES OR BURRS ALLOWED</b>			RN1HN4-12128-1CV1DL-C-PG-Y-S	
MATERIAL: 16 GA/0.063 G-NEAL FINISH: ASA-70 GRAY	DRAWN BY: TT	DATE: 4/15/11	SIZE B	DWG. NO. 050-156-30-REF
DO NOT SCALE DRAWING	CHECKED:	DATE:	REV. 05	
	MFG ENG:	DATE:	SCALE: 1:5	CAD FILE: 050-156-30-REF
	QUALITY ENG:	DATE:	SHEET: 2	OF 2