

REV	ECN#	DESCRIPTION OF CHANGE	DATE	BY	MFG ENG
01	N/A	INITIAL RELEASE		JR	

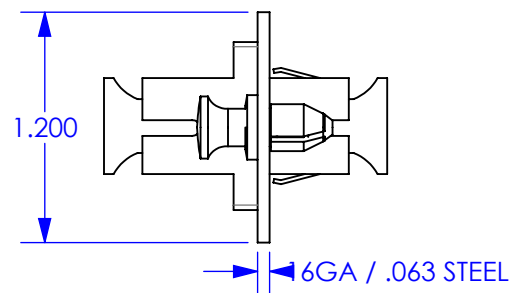
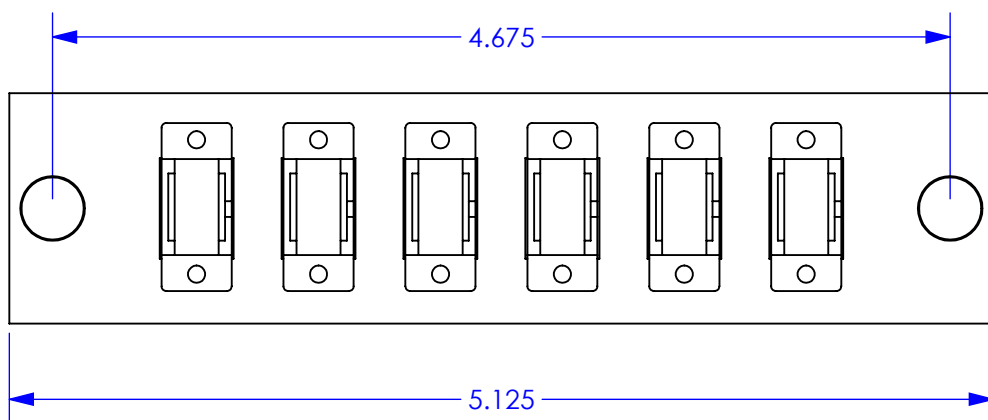
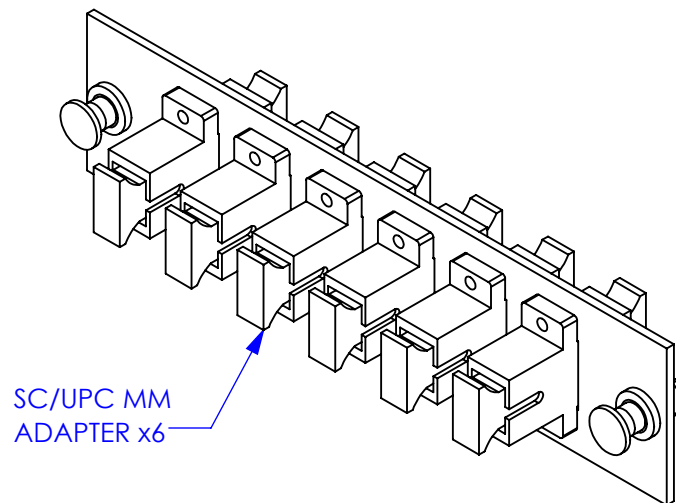
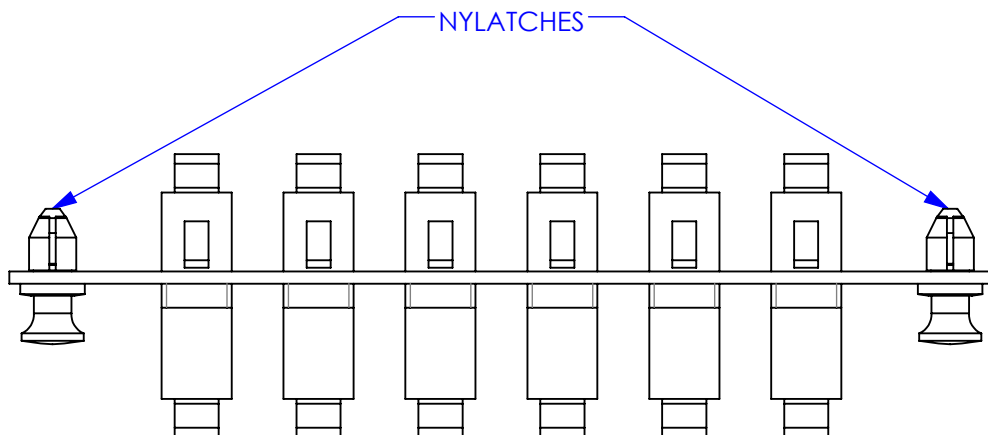

UNLESS OTHERWISE SPECIFIED
DIMENSIONS ARE IN INCHES
TOLERANCES ARE:
FRACTIONS DECIMALS ANGLES
±1/32 .XX=±.03 ±1°
.XXX=±.010

ALL FLATS TO BE ±.005
**NO SHARP EDGES OR
BURRS ALLOWED**

MATERIAL:
SEE B.O.M.
FINISH:
BLACK TEXTURED
DO NOT SCALE DRAWING

THIS DOCUMENT AND THE INFORMATION
CONTAINED THEREIN ARE CONFIDENTIAL
& PROPRIETARY TO MULTILINK AND MAY NOT
BE COPIED OR DISCLOSED TO OTHERS
WITHOUT A WRITTEN CONSENT FROM
MULTILINK. THE INFORMATION IS TO BE
PROMPTLY RETURNED TO MULTILINK UPON
REQUEST.

DRAWN BY: JR DATE: 03/16/09
CHECKED: DATE:
MFG ENG: DATE:
QUALITY ENG: DATE:

Multilink

MSCG-06-MM-P-BK
6 PORT LOADED PANEL

SIZE DWG. NO. 065-242-10REF REV. 01
A
SCALE: 1:1 CAD FILE: 065-242-10REF SHEET 1 OF 1