



## 6 Bay OTN Cabinet

### **Applications:**

An above ground housing to shelter  
Environmentally sensitive equipment from  
Rain, sleet, snow, dust, driving wind, hail,  
Corrosion, and vandalism.

### **Specifications**

Dimensions: 106 ½”W x 36 ½”D x 62 ½”H (270.5cm x 92.7cm x 158.75cm)  
Weight: 1200 Pounds (544.3 kg)

### **Construction:**

Main Body: 1/8” Marine Grade Aluminum 5052-H32  
Hardware: Type 304 Stainless Steel  
Finish: Polyester Powder Coated  
Racks: 3/16” Steel E.I.A. / T.I.A. spacing (10-32 threads)  
Doors: 3 point latch for maximum security

### **Cable Entrance Compartment:**

Four slack storage brackets with heavy duty Velcro® straps to secure cables  
Two entry holes for bringing cables into the main cabinet

### **Powering Compartment:**

100 Amp Service  
12,000 BTU Air conditioner with integrated heater  
60 Amp Generator Hook-up with a manual transfer switch  
AC Load Center:  
    4 GFI Outlets; 120V, 15 Amp  
    1 240V, 30 Amp Outlet  
Separate battery compartment

### **Main Cabinet:**

3 19”-23” Adjustable width racks, also adjustable front to rear position (43” tall)  
3 19”-23” Adjustable width racks, swing out for ease of rear equipment access (40” tall)  
249” of total inches of rack space (142 RU)  
4, 15 Watt Shatter-shield light fixtures

### **Grounding**

All components are grounded to the main copper bus bar

### **Mounting:**

Stainless steel frame structure is provided to be placed in wet concrete for mounting

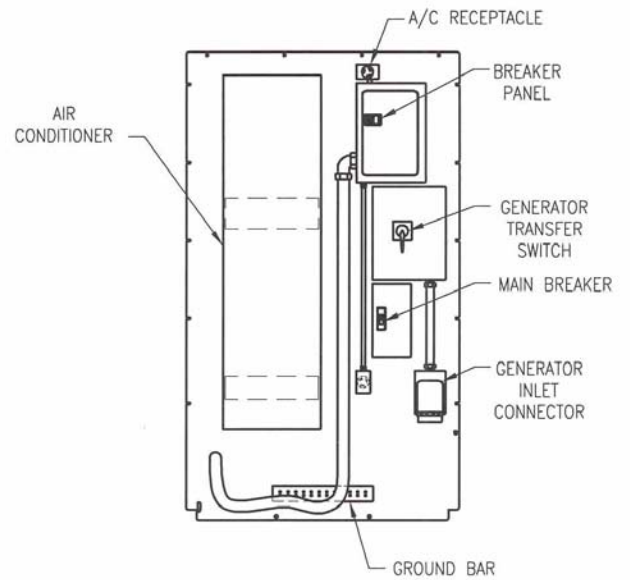
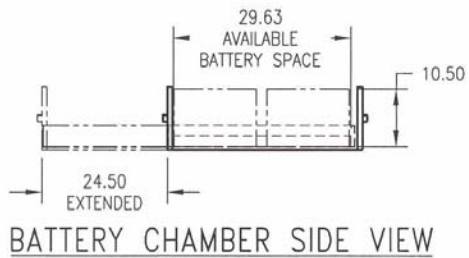
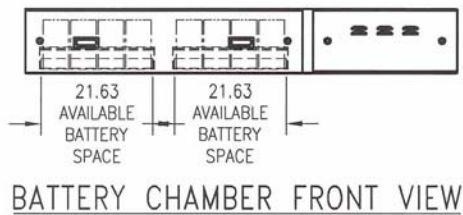
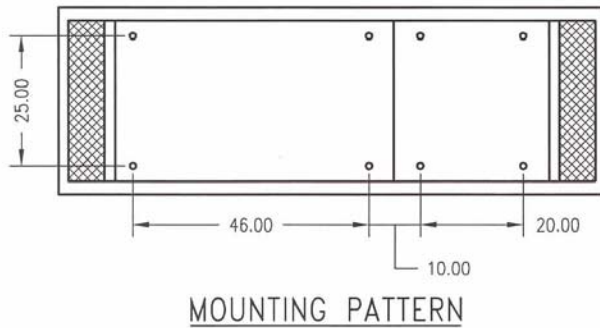
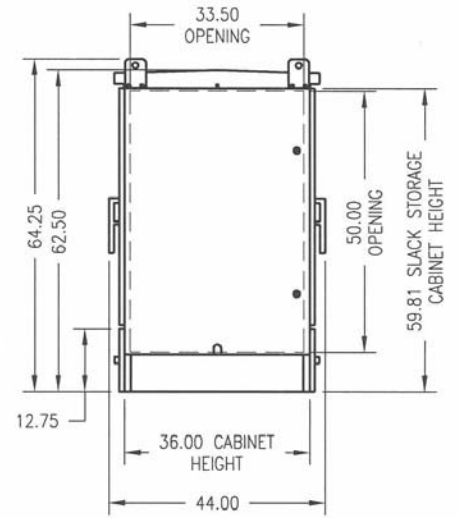
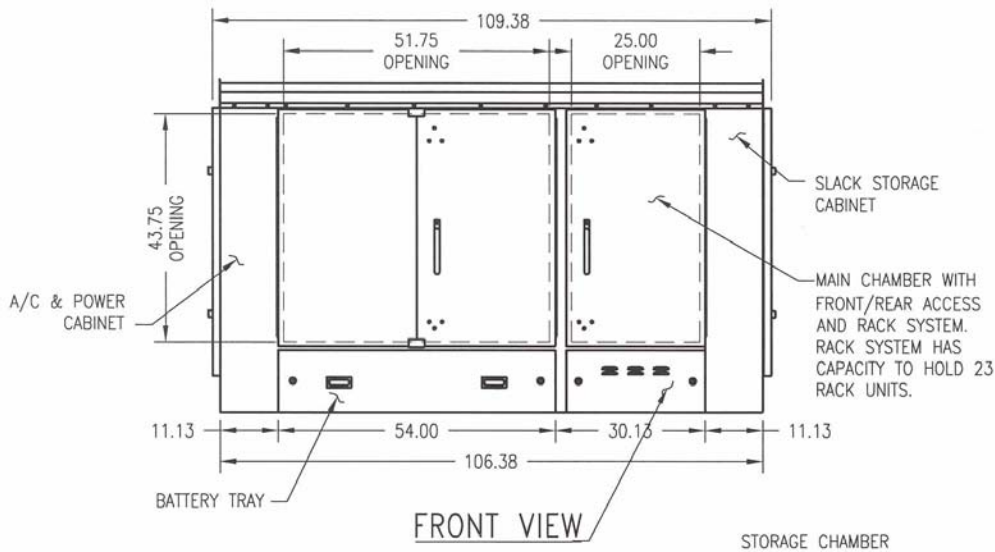

**Multilink**®

582 Ternes Avenue  
Elyria, OH 44035  
Phone: (440) 366-6966  
Fax: (440)-366-6802  
e-mail: engsupport@multilinkbuilt4u.com