



# WC-WM02P

## Features

- Max capacity is 48 "Fibers" by using 2 adapter panels of 6 ports LC Quad;
- Max capacity is 24 "Fibers" by using 2 adapter panels of 6 ports SC Duplex;
- Max capacity is 24 "Fibers" by using 2 adapter panels of 12 ports ST/FC.
- RAL7035 or RAL9005, and RoHS compliant.
- One unit per package which is in 15.16\*11.42\*5.91 inches.
- Weight is 6.07 lbs after packaged.

When using with WC-SPL splice trays remove the (2) 1/2 management spools and use 2 sided sticky back tape

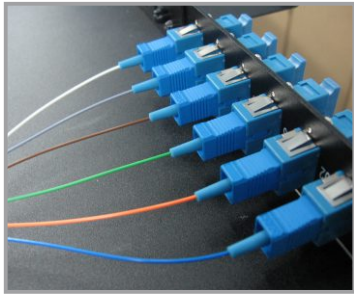
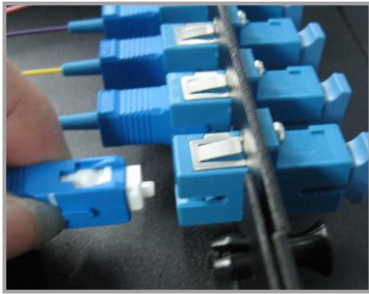

## Application

Dimension For Body and Panel

Machine performance

- Dimension

Other panel plate

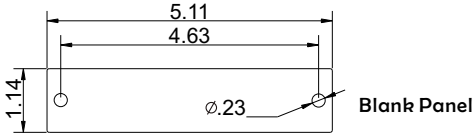

Blank Panel

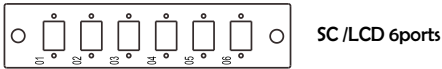

SC/LCD 6ports

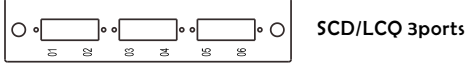

SCD/LCQ 3ports

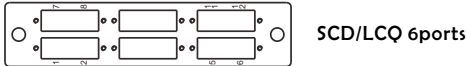

SCD/LCQ 6ports



ST/FC 6ports

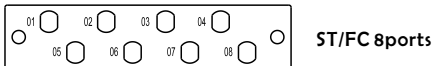

ST/FC 8ports

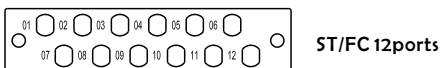

ST/FC 12ports

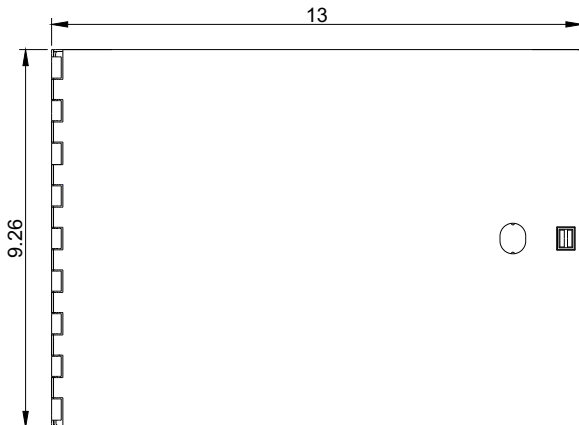
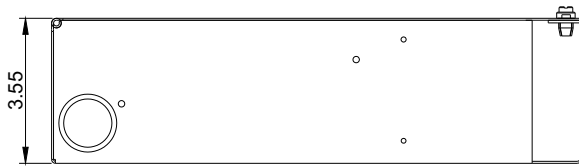

# Assembly

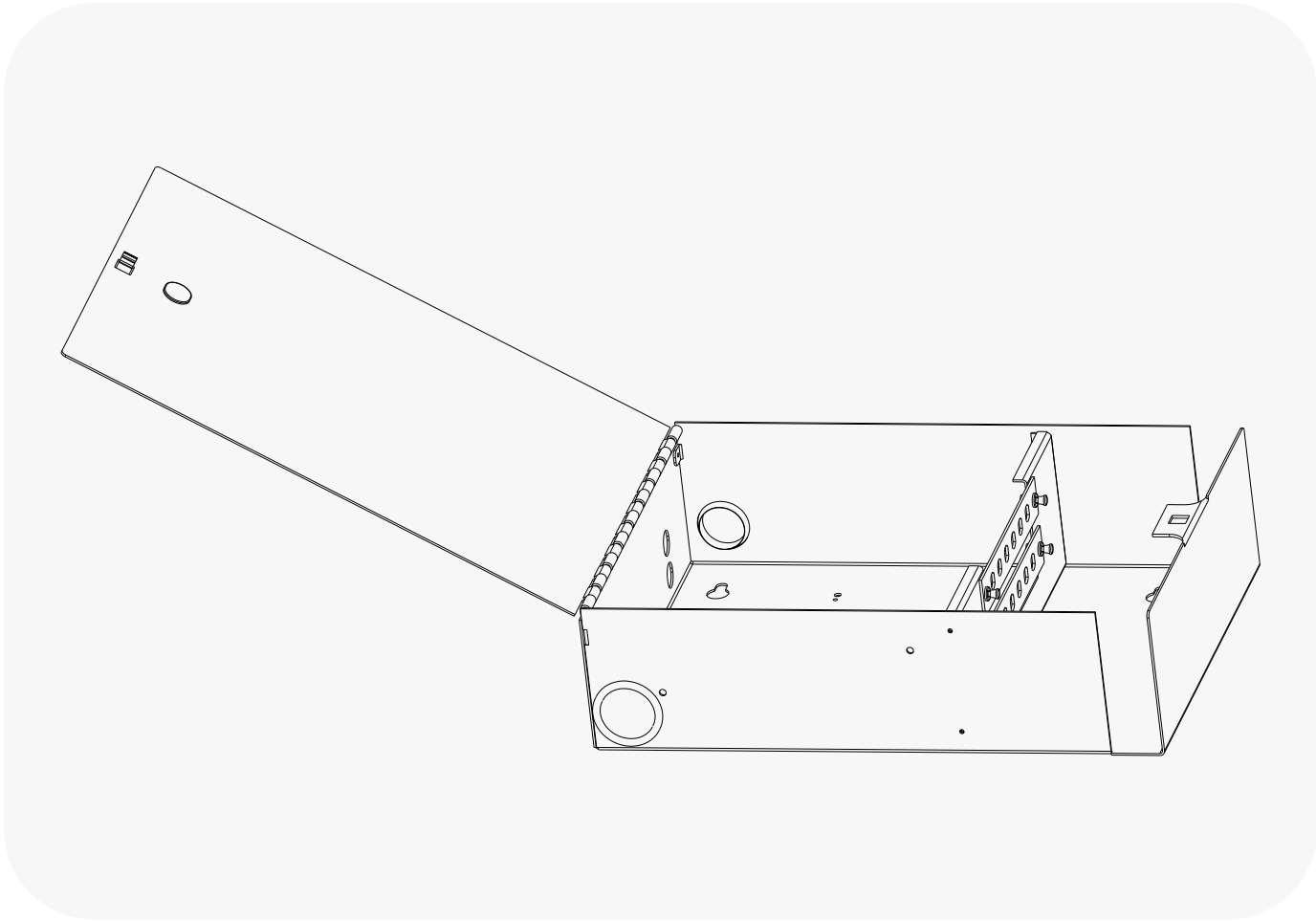

## Included Accessories



Radiation sticker

4" plastic tie wraps

Double sided sticky back tape

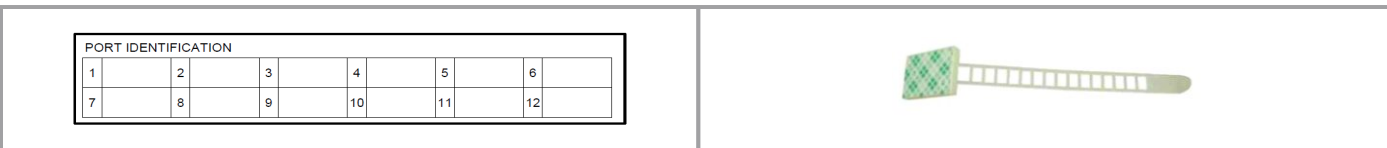

PORT IDENTIFICATION					
1	2	3	4	5	6
7	8	9	10	11	12

Port identification labels

2" cable managers with adhesive bottom

### STANDARD CONFIGURATION

WC-WM02P	
Description	Number
4" plastic tie wraps	4
Radiation sticker	1
2" cable managers with adhesive bottom	4
Port identification labels	2
Double sided sticky back tape (30×30×3 mm)	2